

harman/kardon

AVR 7550HD

7 X 105W 7.1 CHANNEL A/V RECEIVER

SERVICE MANUAL



CONTENTS

ESD WARNING.....	2	PROCESSOR RESET.....	30
LEAKAGE TESTING.....	3	UNIT EXPLODED VIEW.....	31
BASIC SPECIFICATIONS.....	4	EXPLODED VIEW PARTS LIST.....	32
PACKAGING.....	5	AMP BIAS ADJUSTMENT.....	34
FRONT PANEL CONTROLS.....	6	BLOCK DIAGRAM.....	37
REAR PANEL CONNECTIONS.....	8	ELECTRICAL PARTS LIST.....	40
REMOTE CONTROL FUNCTIONS.....	11	PCB DRAWINGS.....	106
CONNECTIONS.....	14	SEMICONDUCTOR PINOUTS.....	124
OPERATION.....	22	SCHEMATICS.....	162
TROUBLESHOOTING GUIDE.....	29	WIRING DIAGRAM.....	186

harman/kardon, Inc.

250 Crossways Park Dr.

Woodbury, New York 11797

Released 2009

Discontinued XXXX

Rev0 1/2010

ELECTROSTATICALLY SENSITIVE (ES) DEVICES

Some semiconductor (solid state) devices can be damaged easily by static electricity. Such components commonly are called Electrostatically Sensitive (ES) Devices. Examples of typical ES devices are integrated circuits and some field effect transistors and semiconductor "chip" components.

The following techniques should be used to help reduce the incidence of component damage caused by static electricity.



1. Immediately before handling any semiconductor component or semiconductor-equipped assembly, drain off any electrostatic charge on your body by touching a known earth ground. Alternatively, obtain and wear a commercially available discharging wrist strap device, which should be removed for potential shock reasons prior to applying power to the unit under test.
2. After removing an electrical assembly equipped with ES devices, place the assembly on a conductive surface such as aluminum foil, to prevent electrostatic charge build-up or exposure of the assembly.
3. Use only a grounded-tip soldering iron to solder or unsolder ES devices.
4. Use only an anti-static solder removal device. Some solder removal devices not classified as "anti-static" can generate electrical charges sufficient to damage ES devices.
5. Do not use freon-propelled chemicals. These can generate electrical change sufficient to damage ES devices.
6. Do not remove a replacement ES device from its protective package until immediately before you are ready to install it. (Most replacement ES devices are packaged with leads electrically shorted together by conductive foam, aluminum foil or comparable conductive material.)
7. Immediately before removing the protective material from the leads of a replacement ES device, touch the protective material to the chassis or circuit assembly into which the device will be installed.

CAUTION : Be sure no power is applied to the chassis or circuit, and observe all other safety precautions.

8. Minimize bodily motions when handling unpackaged replacement ES devices. (Otherwise harmless motion such as the brushing together of your clothes fabric or the lifting of your foot from a carpeted floor can generate static electricity sufficient to damage an ES devices.

PRODUCT SAFETY NOTICE

Each precaution in this manual should be followed during servicing.

Components identified with the IEC symbol  in the parts list are special significance to safety. When replacing a component identified with , use only the replacement parts designated, or parts with the same ratings or resistance, wattage, or voltage that are designated in the parts list in this manual. Leakage-current or resistance measurements must be made to determine that exposed parts are acceptably insulated from the supply circuit before returning the product to the customer.

SAFETY PRECAUTIONS

The following check should be performed for the continued protection of the customer and service technician.

LEAKAGE CURRENT CHECK

Measure leakage current to a known earth ground (water pipe, conduit, etc.) by connecting a leakage current tester between the earth ground and all exposed metal parts of the appliance (input/output terminals, screwheads, metal overlays, control shaft, etc.). Plug the AC line cord of the appliance directly into a 120V AC 60Hz outlet and turn the AC power switch on. Any current measured must not exceed 0.5mA.

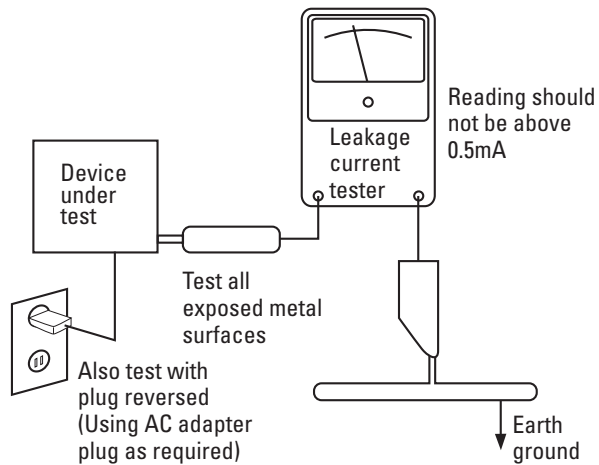

AC Leakage Test

ANY MEASUREMENTS NOT WITHIN THE LIMITS OUTLINED ABOVE ARE INDICATIVE OF A POTENTIAL SHOCK HAZARD AND MUST BE CORRECTED BEFORE RETURNING THE APPLIANCE TO THE CUSTOMER.

AVR 7550HD TECHNICAL SPECIFICATIONS

Audio Section

Stereo Mode, Continuous Average Power (FTC)	
100 Watts per channel, 20Hz–20kHz, @ <0.07% THD, both channels driven into 8 ohms	
Seven-Channel Surround Modes	
Power per Individual Channel	
Front L & R channels:	
85 Watts per channel	@ <0.07% THD, 20Hz–20kHz into 8 ohms
Center channel:	
85 Watts @ <0.07% THD, 20Hz–20kHz into 8 ohms	
Surround (L & R Side, L & R Back) channels:	
85 Watts per channel	@ <0.07% THD, 20Hz–20kHz into 8 ohms
Input Sensitivity/Impedance	
Linear (High-Level)	200mV/47k ohms
Signal-to-Noise Ratio (IHF-A)	100dB
Surround System Adjacent Channel Separation	
Pro Logic® I/II	40dB
Dolby® Digital (AC-3)	55dB
DTS®	55dB
Frequency Response	
@ 1W (+0dB, –3dB)	10Hz –130kHz
High Instantaneous Current Capability (HCC)	
	±60 Amps
Transient Intermodulation Distortion (TIM)	
	Unmeasurable
Slew Rate	
	40V/µsec

FM Tuner Section

Frequency Range	87.5–108.0MHz
Usable Sensitivity	IHF 1.3µV/13.2dB
Signal-to-Noise Ratio	Mono/Stereo 70/68dB
Distortion	Mono/Stereo 0.2/0.3%
Stereo Separation	40dB @ 1kHz
Selectivity	±400kHz, 70dB
Image Rejection	80dB
IF Rejection	90dB

AM Tuner Section

Frequency Range	520–1720 kHz
Signal-to-Noise Ratio	45dB
Usable Sensitivity	Loop 500 µV
Distortion	1kHz, 50% Mod 0.8%
Selectivity	±10kHz, 30dB

Video Section

Television Format	NTSC
Input Level/Impedance	1Vp-p/75 ohms
Output Level/Impedance	1Vp-p/75 ohms
Video Frequency Response (Composite and S-Video)	10Hz–8MHz (–3dB)
Video Frequency Response (Component Video)	10Hz–100MHz (–3dB)
HDMI™	Version 1.3a with 10-bit Deep Color

General

Power Requirement	AC 120V/60Hz	
Power Consumption	120W idle, 1405W maximum (7 channels driven)	
Dimensions	(Product)	(Shipping)
Width	17-5/16 inches (440mm)	20-1/2 inches (520mm)
Height	6-1/2 inches (165mm)	11 inches (280mm)
Depth	17-1/16 inches (435mm)	22-13/16 inches (580mm)
	(Product)	(Shipping)
Weight	44 lb (20kg)	51 lb (23.3kg)

Depth measurement includes knobs, buttons and terminal connections.
Height measurement includes feet and chassis.
Features, specifications and appearance are subject to change without notice.

Harman Kardon and Logic 7 are trademarks of Harman International Industries, Incorporated, registered in the United States and/or other countries. EzSet/EQ, Designed to Entertain and The Bridge II logo are trademarks of Harman International Industries, Incorporated.

Apple, iPod, iTunes and Macintosh are trademarks of Apple Inc., registered in the U.S. and other countries. iPod not included. "Made for iPod" means that an electronic accessory has been designed to connect specifically to iPod and has been certified by the developer to meet Apple performance standards. Apple is not responsible for the operation of this device or its compliance with safety and regulatory standards.

A-BUS is a registered trademark of Leisure Tech Electronics Pty Ltd.

Audiovox is a registered trademark of Audiovox Corporation.

Blu-ray Disc is a trademark of the Blu-ray Disc Association.

CEA is a registered trademark of the Consumer Electronics Association.

Manufactured under license from Dolby Laboratories. Dolby, the double-D symbol and Pro Logic are registered trademarks of Dolby Laboratories. MLP Lossless is a trademark of Dolby Laboratories.

Manufactured under license under U.S. Patent #'s 5,451,942; 5,956,674; 5,974,380; 5,978,762; 6,226,616; 6,487,535; 7,003,467 and other U.S. and worldwide patents issued and pending. DTS, DTS-ES and DTS Neo:6 are registered trademarks, and DTS 96/24, DTS-HD, DTS-HD High Resolution Audio and DTS-HD Master Audio are trademarks, of DTS, Inc. © 1996-2007 DTS, Inc. All Rights Reserved.

EyeConnect is a trademark of Elgato Systems.

Faroudja DCDi Cinema is a trademark of Genesis Microchip Inc.

HD-DVD is a trademark of the DVD Format/Logo Licensing Corporation (DVD FLLC).

HDMI, the HDMI logo and High-Definition Multimedia Interface are trademarks or registered trademarks of HDMI Licensing LLC.

Intel is a trademark of Intel Corporation in the U.S. and other countries.

SACD is a trademark of Sony Corporation.

TiVo is a registered trademark of TiVo Inc.

Windows Media is a registered trademark of Microsoft Corporation in the United States and/or other countries.

XM, SIRIUS and all related marks and logos are trademarks of Sirius XM Radio Inc. and its subsidiaries. All other marks and logos are the property of their respective owners. All rights reserved. XM subscription sold separately. Taxes and a one-time activation fee may apply. XM tuner and home dock required (each sold separately) to receive the XM service. All programming and fees subject to change. It is prohibited to copy, decompile, disassemble, reverse engineer, hack, manipulate or otherwise make available any technology or software incorporated in receivers compatible with the XM Satellite Radio System. Service not available in Alaska or Hawaii.

Please register your AVR 7550HD at www.harmankardon.com. You'll need the product's serial number. At the same time, you can choose to be notified about new products and/or special promotions.

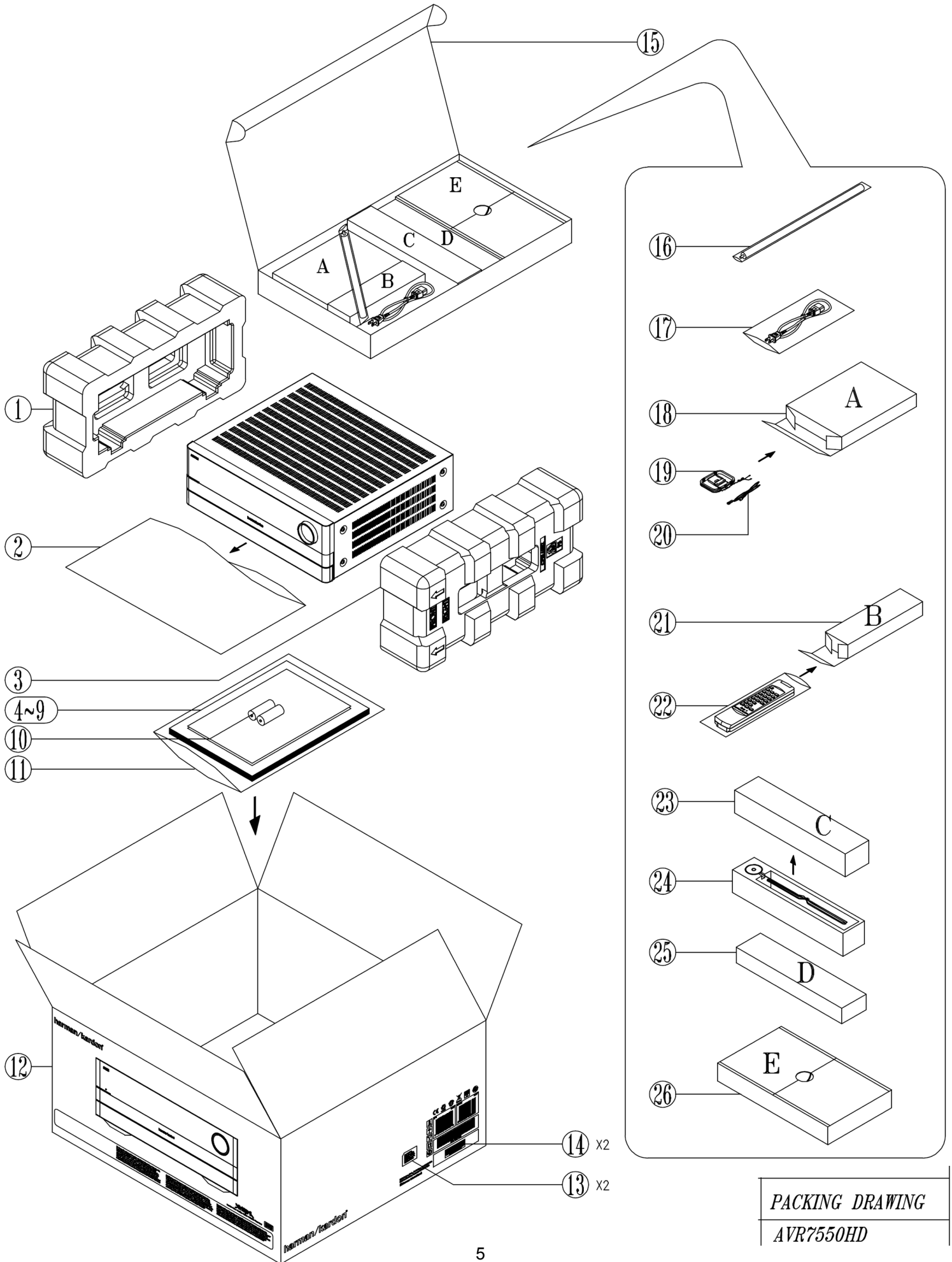

FRONT-PANEL CONTROLS

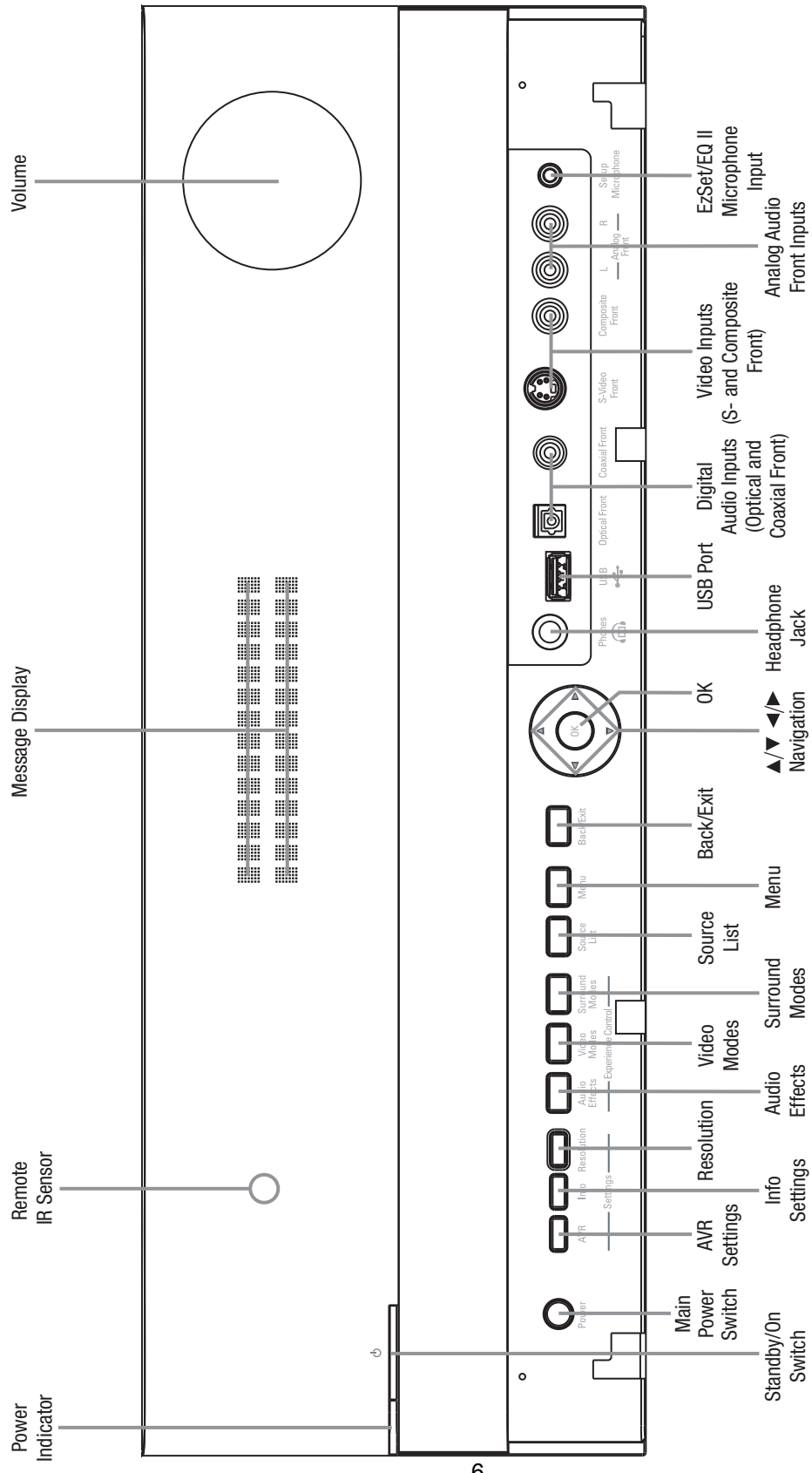

NOTE: To make it easier to follow the instructions throughout the manual that refer to this illustration, a copy of this page may be downloaded from the Product Support section at www.harmankardon.com.

FRONT-PANEL CONTROLS

Power Indicator: This LED has three possible modes:

- **Main Power Off:** When the AVR is unplugged or the Main Power Switch is off, this LED is off.
- **Standby:** Amber indicates that the AVR is ready to be turned on.
- **On:** When the AVR is turned on, this LED turns white.

NOTE: If the PROTECT message ever appears, turn off the AVR and unplug it. Check all speaker wires for a possible short. If none is found, bring the unit to an authorized Harman Kardon service center for inspection and repair before using it again.

Standby/On Switch: This electrical switch turns the receiver on, or places it in Standby mode for quick turn-on.

Front-Panel Door (not shown): Most of the controls and connectors described below are hidden behind this door. To open it, gently grab the right or left edge of the door and pull it forward and down.

Main Power Switch: This mechanical switch turns the power supply on or off. It is usually left on, and cannot be turned on or off using the remote control.

AVR Settings Button: Press this button to access the AVR's main menu.

Info Settings Button: Press this button to directly access the AVR's Source Info submenu, which contains the settings for the current source.

Resolution: Press this button to access the AVR's video output resolution setting: 480i, 480p, 720p, 1080i or 1080p.

IMPORTANT NOTE: If the AVR's video output resolution is set higher than the capabilities of the actual connection, you will not see a picture. If the best available video connection from the AVR to the TV is either composite or S-video, press this button and change the resolution to 480i.

Audio Effects: Press this button to directly access the Audio Effects submenu, which allows adjustment of the tone and other audio controls. See the Initial Setup section for more information.

Video Modes: Press this button for direct access to the Video Modes submenu, which contains settings that may be used to improve the picture, if necessary, after you have adjusted the picture settings using the video display or TV.

Surround Modes: Press this button to select a surround sound (e.g., multichannel) mode. The Surround Modes menu will appear on screen, and the menu line will appear in the front-panel display. See the Advanced Functions section for more information on surround modes.

Source List: Press this button to select a source device, which is a component where a playback signal originates, e.g., DVD.

Menu Button: Press to display the menus for the tuner, the USB device, The Bridge II, the Network or Internet Radio, when any of those sources is in use.

Back/Exit: Press this button to return to the previous menu, or to exit the menu system.

▲/▼◀/▶ Navigation: These buttons are used to navigate the AVR's menus, including the menus for the tuner, the USB device, The Bridge II, the Network and Internet Radio.

OK: Press this button to select the currently highlighted item.

Headphone Jack: Plug a 1/4" stereo headphone plug into this jack for private listening.

USB Port: Connect a USB flash drive, to play audio files in the MP3 or WMA format or still images in the JPEG format. DO NOT connect a PC, keyboards, pointing devices or other peripheral products to the AVR 7550HD. Do not connect an iPod here; use The Bridge II instead. Do not connect a USB hub or multi-card device.

Digital Audio, Video and Analog Audio Front Inputs: Connect a source component that will only be used temporarily, such as a digital camera or game console, to these jacks. Use only one type of audio and one type of video connection.

NOTE: The AVR's menus refer to these jacks as the Optical Front, Coaxial Front, Composite Front, S-Video Front and Analog Front inputs.

EzSet/EQ II Microphone Input: This jack is used to connect the supplied microphone for the EzSet/EQ II procedure described in the Initial Setup section.

Volume Knob: Turn this knob to raise or lower the volume.

Message Display: Various messages appear in this two-line display in response to commands and changes in the incoming signal. In normal operation, the current source name appears on the upper line, while the surround mode is displayed on the lower line. When the on-screen display menu system (OSD) is in use, the current menu settings appear.

Remote IR Sensor: This sensor receives infrared (IR) commands from the remote control. It is important to ensure that it is not blocked. If covering the sensor is unavoidable, use an optional Harman Kardon HE 1000, or other infrared receiver, connecting it to the Remote IR Input on the AVR 7550HD's rear panel.

REAR-PANEL CONNECTIONS

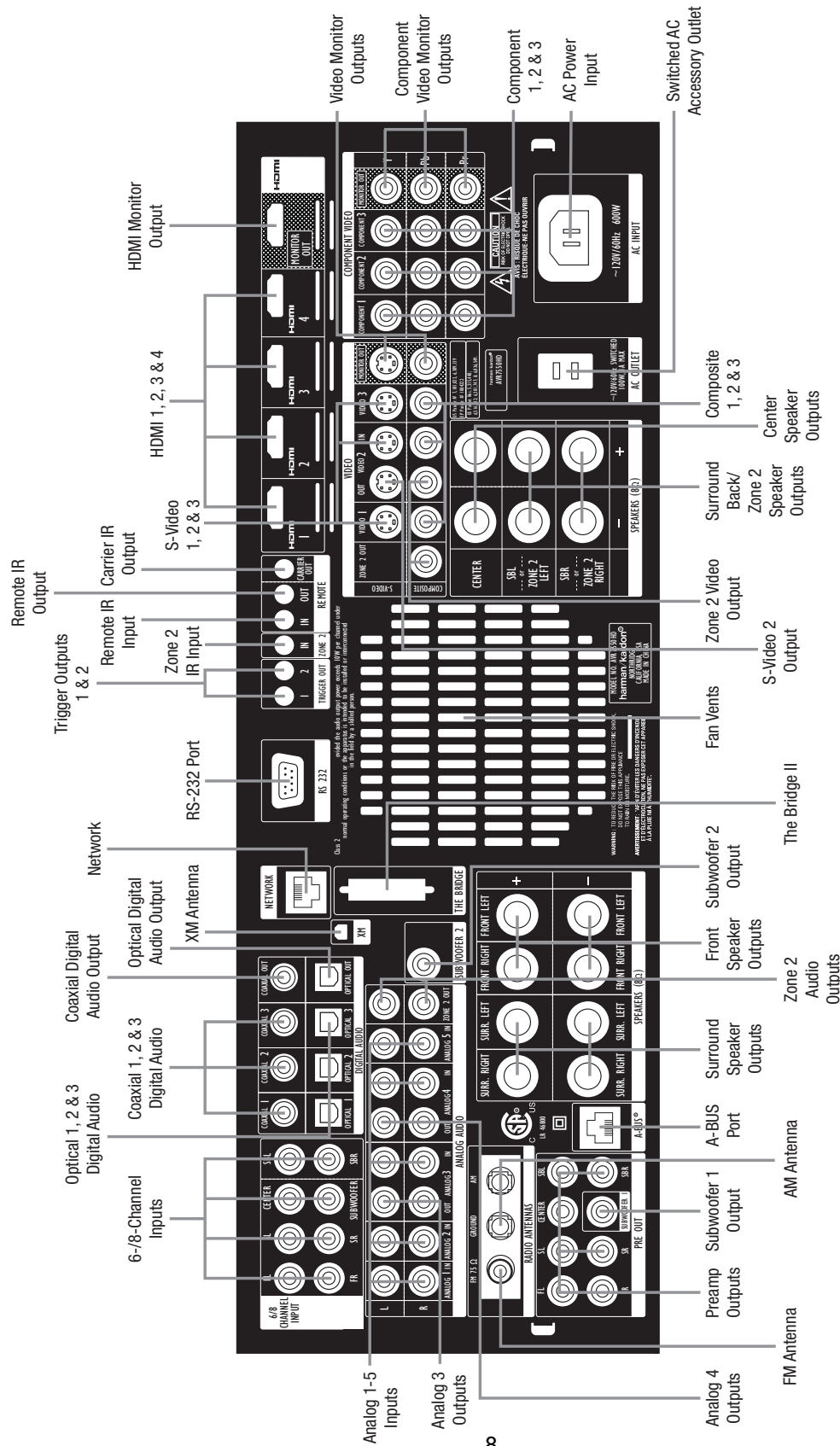

NOTE: To make it easier to follow the instructions throughout the manual that refer to this illustration, a copy of this page may be downloaded from the Product Support section at www.harmankardon.com.

REAR-PANEL CONNECTIONS

6-/8-Channel Inputs: Connect the multichannel analog audio outputs of a non-HDMI player (DVD-Audio, SACD™, Blu-ray Disc™ or HD-DVD, or any other external decoder) to these jacks.

Coaxial 1/2/3 and Optical 1/2/3 Digital Audio Inputs: If a source has a compatible digital audio output, and if you are not using an HDMI connection for audio for the device, connect it to one of these jacks to hear digital audio formats, such as Dolby Digital, DTS and linear PCM. Use only one type of digital audio connection for each source.

Coaxial and Optical Digital Audio Outputs: If a source is also an audio recorder, connect one of the Digital Audio Outputs to the recorder's matching input for improved recording quality. Only PCM digital audio signals are available for recording. Both coaxial and optical digital audio signals are available at either Digital Audio Output.

XM Antenna Jack: Plug in an XM Connect-and-Play or Mini-Tuner antenna module here.

Network Jack: Plug in an RJ-45-compatible cable that connects to a personal computer (PC), router or Internet access. When connected to a PC, the AVR 7550HD is capable of playing audio and JPEG files stored on the PC. When connected to the Internet, the AVR 7550HD may be used to enjoy Internet Radio. See pages 36 and 37 for more information.

RS-232 Serial Port: This bi-directional port may be used to control the AVR 7550HD using an RS-232 serial control link to a compatible computer or programmable remote control system. Due to the complexity of programming RS-232 commands, connections and programming for control purposes should be performed by a qualified custom installer.

Trigger 1 and 2 Outputs: Connect these control jacks to the trigger input jack of an external component, such as an audio power amplifier, that you want to power on any time the AVR 7550HD is turned on, without using the AVR's Switched Accessory Outlet for power. When this connection is used, the AVR 7550HD will automatically send a low-voltage signal to the connected device that triggers it to turn on when the AVR 7550HD is on, and off when the AVR 7550HD is placed in the Standby Mode. The connected component must respond to 6-volt presence as the control signal.

The Trigger 2 Output may be programmed to transmit its signal only when certain of the AVR's source inputs are selected. For example, to lower a screen when watching a DVD movie, but not while listening to the tuner, connect the Trigger 2 Output to the screen and program it to be on when the DVD source is selected, but off when the AM, FM or XM bands are in use. See the Initial Setup section for more information on programming this setting in the Info Settings menus for each source.

Zone 2 Infrared (IR) Input: Connect a remote IR receiver located in the remote zone of a multizone system to this jack to control the AVR (and any source devices connected to the Remote IR Output) from the remote zone.

Remote Infrared (IR) Input and Output: When the remote IR receiver on the front panel is blocked, connect an optional

IR receiver to the Remote IR Input jack. The Remote IR Output may be connected to the Remote IR Input of a compatible product to enable remote control through the AVR.

Remote IR Carrier Output: This output is similar in function to the Remote IR Output, with the difference that this jack outputs the full infrared signal as received by the AVR's IR sensor or the Remote IR Input, while the Remote IR Output jack outputs a "stripped" signal that has no carrier frequency.

HDMI Inputs and Output: HDMI (High-Definition Multimedia Interface) is a connection for transmitting digital audio and video signals between devices. Connect up to four HDMI-equipped source devices to the HDMI inputs using a single-cable connection.

When you connect the HDMI Output to your video display, the AVR 7550HD will automatically transcode analog video signals to the HDMI format, upscaling to as high as 1080p.

NOTES: When connecting a DVI-equipped display to one of the HDMI Outputs:

- Use an HDMI-to-DVI adapter.
- Make sure the display is HDCP-compliant. If it isn't, do not connect it to an HDMI Output; use an analog video connection instead.
- Always make a separate audio connection.

Analog 1 – 5 Inputs: Connect the left and right analog audio outputs of a source device to any of these inputs. These inputs may be paired with any video inputs.

NOTES:

- The Analog 3 and 4 inputs are each associated with a set of outputs. Consider using these connectors for an audio or video recorder.
- You may optionally connect a source to both an analog and digital audio input. This is useful for making recordings, for multizone applications or simply as a backup.

Analog 3 and 4 Outputs: Connect either of these analog audio outputs to the analog audio inputs of a recording device. A signal is available at these outputs whenever an analog audio source is playing.

Zone 2 Audio Outputs: Connect these jacks to an external amplifier to power the speakers in the remote zone of a multizone system.

Subwoofer 1 and 2 Outputs: If you have a powered subwoofer with a line-level input, connect it to the Subwoofer 1 Output. For improved performance, connect a second powered subwoofer to the Subwoofer 2 Output.

The Bridge II Input: Connect the included Harman Kardon [™]Bridge II docking station to this input for use with most docking iPod models, 4G and later (not included). Turn the receiver off (Standby mode) when connecting The Bridge II.

REAR-PANEL CONNECTIONS

Fan Vents: This area contains vents used by the AVR 7550HD's fan to cool the system. Maintain a clearance of at least 3 inches from the nearest surface to avoid overheating the unit. It is normal for the fan to remain off at most normal volume levels. An automatic temperature sensor turns the fan on only when it is needed.

IMPORTANT NOTE: Never block the fan vents, as doing so could allow the AVR to overheat to dangerous levels.

Zone 2 Video Output: Connect this composite video jack to a video display located in the remote zone of a multizone system. When the multizone system is in use, viewers in the remote zone will be able to see the AVR's on-screen text menus and any available source video, as long as the source is connected to a Composite Video Input, and that input is specified for that source in the Zone 2 Video setting of the Info Settings menu.

Composite and S-Video 1, 2 and 3 Video Inputs: Use these jacks to connect your video-capable source components (e.g., VCR, DVD player, cable TV box) to the receiver. Use only one type of video connection for each source.

Composite and S-Video 2 Outputs: Connect one of these analog video outputs to the composite or S-video inputs of a recording device. A signal is available at these outputs whenever an analog video source is playing.

Composite and S-Video Monitor Outputs: If any of your sources use composite or S-video connections, connect one or both of these monitor outputs to the corresponding inputs on your video display. If your video display is equipped with HDMI or component video inputs, these connections are unnecessary, as the AVR 7550HD will convert the composite or S-video source signal to the correct format for a single video-cable connection to the TV.

Component Video 1, 2 and 3 Inputs: If a video source has analog component video (Y/Pb/Pr) capability, and if you are not using an HDMI connection, connect the component video outputs of the source to one of the sets of component video inputs. Do not make any other video connections to that source.

Component Video Monitor Outputs: If you are using one of the Component Video Inputs and your television or video display is component-video-capable (but does not have HDMI), connect these jacks to the video display.

NOTES:

- Due to copy-protection restrictions, there is no output at the Component Video Monitor Outputs for copy-protected sources.
- Composite and S-video signals are upscaled to as high as 1080i and available at these outputs. If your video display's best connection is component video, it is the only video connection required from the AVR to the display.

AM and FM Antenna Terminals: Connect the included AM and FM antennas to their respective terminals for radio reception.

Preamp Outputs: Connect these jacks to an external amplifier if more power is desired. The Surround Back/Zone 2 Preamp Outputs may be used with an external amplifier to power the remote zone of a multizone system.

A-BUS Port: Use a Category 5/5e cable to connect this port to optional A-BUS equipment for multizone operation. When the A-BUS system is used, it is possible to have a full 7.2-channel system in the main listening room at the same time the multizone system is in use.

Front, Center and Surround Speaker Outputs: Use two-conductor speaker wire to connect each set of terminals to the correct speaker. Remember to observe the correct polarity (positive and negative connections).

Surround Back/Zone 2 Speaker Outputs: These speaker outputs are used for the surround back channels in a 7.2-channel home theater, or may be reassigned to a remote room for multizone operation.

Switched AC Accessory Outlet: You may plug the AC power cord of one source device into this outlet, and it will turn on whenever you turn on the receiver. Do not use a source that consumes more than 50 watts of power.

AC Power Input: After you have made all other connections, plug the AC power cord into this receptacle and into an unswitched wall outlet.

MAIN REMOTE CONTROL FUNCTIONS

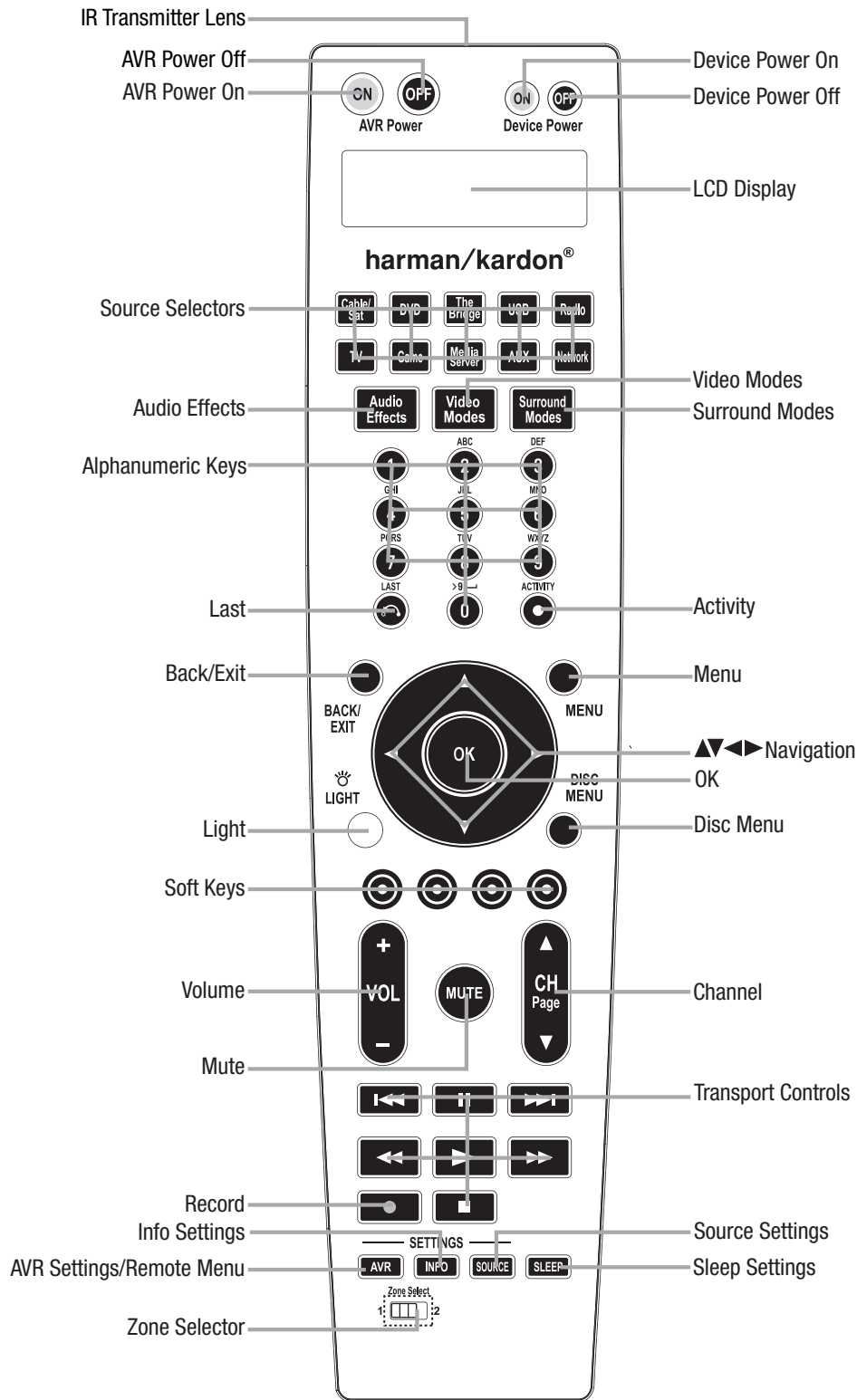

NOTE: To make it easier to follow the instructions throughout the manual that refer to this illustration, a copy of this page may be downloaded from the Product Support section at www.harmankardon.com.

MAIN REMOTE CONTROL FUNCTIONS

The AVR 7550HD remote is capable of controlling up to 14 devices, including the AVR itself, an iPod docked in the included The Bridge II, a USB device and a Network device (see page 37 for details). During the installation process, you may program the codes for your source components into the remote. To operate a component, press its Selector button to change the device mode. The device mode will appear on the top line of the remote's LCD Display.

NOTE: Four of the sources do not have dedicated Source Selectors: Source A, Source B, Source C and Source D. To select one of these sources, first press the AVR Settings Button, then press the appropriate Soft Key: Red for Source A, Green for Source B, Yellow for Source C and Blue for Source D. These sources may also be selected using the AVR Settings menu.

Each Source Selector has been preprogrammed to control certain types of components, with only the codes specific to each brand and model changing, depending on which product code is programmed. The AUX and Cable/SAT Source Selectors may be used for multiple device types. All of the external Source Selectors may be reassigned to other device types (see Initial Setup section).

AUX Source Selector: CD player, VCR, HDTV set-top box, PVD or TiVo® set-top box.

Cable/SAT Source Selector: Cable set-top box or satellite set-top box.

IMPORTANT NOTE: All of the AVR 7550HD's audio and video inputs are independently assignable. Select the inputs to which the device is physically connected during Initial Setup. Any device may be connected to any compatible input and given any name (e.g., DVD or Game).

Most of the buttons on the remote have dedicated functions, although the precise codes transmitted vary, depending on the device mode. Due to the wide variety of functions for various source devices, only a few of the most-often used functions on the remote have been included: alphanumeric keys, transport controls, television-channel control, menu access, and power on and off.

Buttons dedicated to the AVR are available at any time, even in another device mode: AVR Power On and Off, Audio Effects, Video Modes, Surround Modes, Volume, Mute and Sleep Settings. Press the AVR Settings Button near the bottom of the remote to return it to AVR mode.

A button's function depends on which component is being controlled. See Table A14 in the appendix for listings of the functions for each type of component.

IR Transmitter Lens: As buttons are pressed on the remote, infrared codes are emitted through this lens.

AVR Power On Button: Press to turn on the AVR. The Master Power Switch behind the front-panel door must be on.

AVR Power Off Button: Press to turn off the AVR 7550HD.

Device Power On Button: Press a device's Source Selector, then press this button to turn on the device.

Device Power Off Button: Press a device's Source Selector, then press this button to turn off the device.

LCD Display: This two-line text display informs you of the current device mode (i.e., which source is active) on the upper line. When you press a key, the command will appear briefly on the lower line.

Source Selectors: Press one of these buttons to select a source device, e.g., DVD, CD, cable TV, satellite or HDTV tuner. This will also turn on the receiver and switch the remote's device mode to operate the source. The first press of the Radio Selector switches the AVR to the last-used tuner band (AM, FM or XM). Each successive press changes the band. Similarly, the Network Button toggles between the Network and Internet Radio sources.

Audio Effects: Press to directly access the Audio Effects submenu, which allows adjustment of the AVR's tone and other audio controls. See the Initial Setup section for more information.

Video Modes: Press for direct access to the Video Modes submenu, which contains picture settings to be used after you have adjusted the picture settings on the video display or TV. See the Advanced Functions section for more information.

Surround Modes: Press to directly access the Surround Modes submenu. Scroll to the lines for the Surround Mode categories: Auto Select, Virtual Surround, Stereo, Movie, Music or Video Game. The surround mode will change when the menu line is highlighted.

To change the surround mode for the selected category, press the OK Button when the menu line for the Surround Mode category matching the audio program is highlighted, and select one of the available surround mode options using the ▲/▼ Buttons. Press the OK Button.

See the Advanced Functions section for more information on surround modes.

Alphanumeric Keys: Use these buttons to enter numbers for radio station frequencies or channels, or to select station presets.

Last Channel: When controlling the tuner; a cable, satellite or HDTV set-top box; or a TV, press this button to return to the previous station or channel. For Internet Radio, this is only available to toggle between stations previously saved as presets.

Activity: With this button, up to 11 Activities may be programmed to transmit a series of commands with a single press. Execute an Activity by pressing this button, then the Alphanumeric Key (or the AVR Power On or Off Button by themselves) into which it was programmed. See the Advanced Functions section for more information on Activities.

Back/Exit: Press to return to the previous menu or to exit the menu system.

Menu Button: This button is used within the Now Playing menu for the tuner (including XM Radio), USB, The Bridge II, Internet Radio and the Network, and to display the main menu on some source devices. To display the AVR 7550HD's main menu, press the AVR Settings Button.

Navigation(▲/▼◀/▶) and OK Buttons: These buttons are used to make selections within the menu system and to operate the tuner.

MAIN REMOTE CONTROL FUNCTIONS

Light: Press to illuminate the buttons on the remote. Press it again to turn the back light off, or wait 10 seconds after the last button press for the light to turn off on its own.

Disc Menu: While a DVD is playing, press the DVD Source Selector, then this button, to display the disc's menu.

Soft Keys: These buttons are used to select sources A, B, C and D (see note on page 13), or for other functions with some source devices. See Table A14 in the appendix for details. They are also used with a Teletext-capable television if your broadcast, cable or satellite provider offers Teletext service.

Volume Control: Press to raise or lower the volume.

Mute Button: Press to mute the AVR 7550HD's speaker and headphone outputs. To end the muting, press this button, adjust the volume, or turn off the receiver.

Channel/Page Control: When the tuner has been selected, this control changes the station. When using The Bridge II or a USB drive, this control allows you to scroll a page at a time through a long list of content. While operating a cable, satellite or HDTV set-top box or a television, press these buttons to change channels.

Transport Controls: These buttons are used to control source playback.

Record Button: Use this button to make recordings when an audio or video recorder is in use.

AVR Settings/Remote Menu Button: Press to display the AVR's Main Menu, or to switch the remote to AVR device mode. Press and hold for 3 seconds to access the menu for the remote control. The menu commands and options will appear in the LCD Display.

The functions are: program the codes for a device, learn codes for an individual key, change the device type of a selector, program an activity (macro), program punch-through functions for channel control or transport control, rename a device or a key's function, change the brightness of the back light, reset the remote to its factory-default status, or exit the remote menu. See the Initial Setup section for details on programming the remote, and see the Advanced Functions section for further information.

Info Settings Button: Press to display the AVR's Info Menu, which contains the settings for the current source.

Source Settings Button: Press a Source Selector and then this button to display a source device's settings menu.

Sleep Settings Button: Press to activate the sleep timer, which turns off the receiver after a programmed period of time of up to 90 minutes. Each press decreases the timer by 10 minutes, ending with the "Sleep Off" message.

Zone Selector: Use this switch to select whether AVR commands will affect the main listening area (Zone 1) or the remote zone of a multizone system (Zone 2). For normal operation, leave the switch in the Zone 1 position.

CONNECTIONS

There are different types of audio and video connections used to connect the receiver, the speakers, the video display, and the source devices. The Consumer Electronics Association has established the CEA® color-coding standard. See Table 1.

Table 1 – Connection Color Guide

Audio Connections					
Front (FL/FR)		Left		Right	
		White		Red	
Center (C)			Green		
Surround (SL/SR)		Blue		Gray	
Surround Back (SBL/SBR)		Brown		Tan	
Subwoofer (SUB)			Purple		
Digital Audio Connections					
Coaxial				Orange	
Optical		Input		Output	
Video Connections					
Component	Y	Green	Pb	Blue	Pr Red
Composite				Yellow	
S-Video					
HDMI™ Connections (digital audio/video)					
HDMI					

Speaker Connections

Speaker cables carry an amplified signal from the receiver's speaker terminals to each loudspeaker. They contain two wire conductors, or leads, inside plastic insulation, that are differentiated in some way, such as with colors or stripes.

The differentiation preserves polarity, without which low-frequency performance can suffer. Each speaker is connected to the receiver's speaker-output terminals using two wires, one positive (+) and one negative (-). Always connect the positive terminal on the speaker, which is usually colored red, to the positive terminal on the receiver, which is colored as indicated in the Connection Color Guide above (Table 1). The negative terminals are both black.

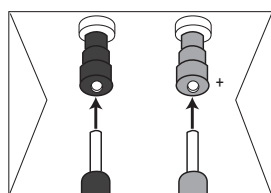

The AVR 7550HD uses binding-post speaker terminals that can accept banana plugs or bare-wire cables. Banana plugs are inserted into the hole in the middle of the terminal cap. See Figure 1.

Figure 1 – Binding-Post Speaker Terminals With Banana Plugs

Bare wire cables are installed as follows (see Figure 2):

1. Unscrew the terminal cap until the pass-through hole is revealed.
2. Insert the bare end of the wire into the hole.
3. Hand-tighten the cap until the wire is held snugly.

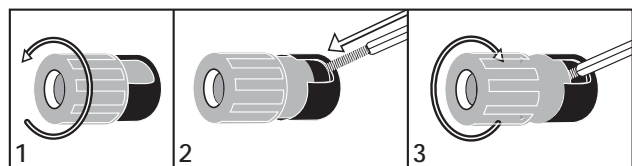

Figure 2 – Binding-Post Speaker Terminals With Bare Wires

Subwoofer

The subwoofer is dedicated to the low frequencies (bass), which require more power. To obtain the best results, most speaker manufacturers offer powered subwoofers that contain their own amplifier. Usually, a line-level (nonamplified) connection is made from the receiver's Subwoofer Output to a corresponding jack on the subwoofer, as shown in Figure 3. The AVR 7550HD offers the option of connecting two subwoofers to independent outputs, which enables the EzSet/EQ II process to configure each subwoofer precisely to account for its unique characteristics and placement within the room.

Although the purple subwoofer outputs look similar to full-range analog audio jacks, they are filtered to allow only the low frequencies to pass. Don't connect these outputs to any other devices.



Figure 3 – Subwoofer

CONNECTING SOURCE DEVICES TO THE AVR

Audio and video signals originate in "source devices," including your Blu-ray Disc or DVD player, CD player, DVR (digital video recorder) or other recorder, tape deck, game console, cable or satellite television box, MP3 player, USB drive or network device. The AVR's tuner also counts as a source, even though no external connections are needed, other than the FM and AM antennas and the XM antenna module.

Separate connections are required for the audio and video portions of the signal, except for digital HDMI connections. The types of connections used depend upon the capabilities of the source device and video display.

Audio Connections

There are two types of audio connections: digital and analog. Digital audio signals are required for listening to sources encoded with digital surround modes, such as Dolby Digital and DTS, or for noncompressed PCM digital audio. There are three types of digital audio connections: HDMI, coaxial and optical. Do not use more than one type of digital audio connection for each source device. However, it's okay to make both analog and digital audio connections to the same source.

NOTE: HDMI signals may carry both audio and video. If your video display device has an HDMI input, make a single HDMI connection from each source device to the AVR. Usually, a separate digital audio connection is not required. Turn the volume on your television all the way down.

Digital Audio

The AVR 7550HD is equipped with four HDMI (High-Definition Multimedia Interface) inputs, and one output. HDMI technology enables digital audio and video information to be carried using a single cable, delivering the highest quality picture and sound.

The AVR 7550HD uses HDMI (V.1.3a with Deep Color) technology and is capable of processing both the audio and video components

CONNECTIONS

of the HDMI data, minimizing the number of cable connections in your system. The AVR 7550HD implements Deep Color, which increases by an order of magnitude the shades of color that can be displayed, and the latest lossless multichannel audio formats, including Dolby TrueHD and DTS-HD Master Audio.

NOTE: Some DVD-Audio, SACD, Blu-ray Disc and HD-DVD players only output multichannel audio through their multichannel analog outputs. Make a separate analog audio connection in addition to the HDMI connection, which is still used for video and to listen to Dolby Digital, DTS or PCM materials that may be stored on the disc.

The AVR 7550HD converts analog video signals to the HDMI format, including its on-screen menus, upscaling to high-definition 1080p resolution.

The HDMI connector is shaped for easy plug-in (see Figure 4). If your video display has a DVI input and is HDCP-compliant, use an HDMI-to-DVI adapter (not included). A separate audio connection is required. HDMI cable runs are limited to about 10 feet.



Figure 4 – HDMI Connection

If your video display or source device is not HDMI-capable, use one of the analog video connections (composite, S- or component video) and a separate audio connection.

Coaxial digital audio jacks are usually color-coded in orange. Although they look similar to analog jacks, you should not connect coaxial digital audio outputs to analog inputs or vice versa. See Figure 5.

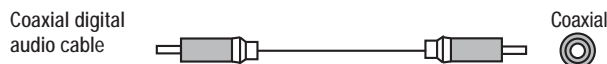

Figure 5 – Coaxial Digital Audio

Optical digital audio connectors are normally covered by a shutter to protect them from dust. The shutter opens as the cable is inserted. Input connectors are color-coded using a black shutter, while outputs use a gray shutter. See Figure 6.



Figure 6 – Optical Digital Audio

Analog Audio

Analog connections require two cables, one for the left channel (white) and one for the right channel (red). These two cables are often attached to each other. See Figure 7.

For sources that are capable of both digital and analog audio, you may make both connections.

The analog audio connection is required for multizone operation, as the AVR 7550HD's multizone system is not capable of converting a digital signal to analog format. Use the analog audio connections even with the Surround Back/Zone 2 speaker outputs, in case another 2-channel digital audio source is in use in the main listening area. The AVR 7550HD is only capable of processing one PCM source at a time.

You may only record materials from DVDs or other copy-protected sources using analog connections. Remember to comply with all copyright laws, if you choose to make a copy for your own personal use.



Figure 7 – Analog Audio

Multichannel analog connections are used with high-definition sources that decode the copy-protected digital content, such as some DVD-Audio, SACD, Blu-ray Disc and HD-DVD players. See Figure 8. The multichannel analog audio connection is not required for players compliant with HDMI version 1.1 or better, or that output linear PCM signals via an HDMI connection. Consult the owner's guide for your disc player for more information.

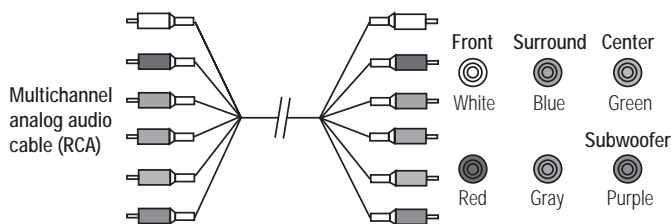

Figure 8 – Multichannel Analog Audio

The AVR 7550HD also includes a proprietary, dedicated audio connection for The Bridge II docking station for iPod. If you own a docking iPod (most models, 4G or later), connect The Bridge II (included) to The Bridge II port on the receiver. See Figure 9. Dock your iPod (not included) in The Bridge II, and you may listen to your audio materials through your high-performance audio system. You may view still images or video materials stored on a photo- or video-capable iPod that supports video browsing. Use the AVR 7550HD remote to control the iPod, with navigation messages displayed on the front panel and on a video display connected to the AVR. The Bridge II outputs analog audio to the AVR 7550HD, and is available to the multiroom system.



Figure 9 – The Bridge II port

Video Connections

Many sources output both audio and video signals (e.g., Blu-ray Disc or DVD player, cable television box, HDTV tuner, satellite box, VCR, DVR). In addition to the audio connection, make one type of video connection for each of these sources (only one at a time for any source).

Digital Video

If you have already connected a source device to one of the HDMI inputs, you have automatically made a video connection, as the HDMI signal includes both digital audio and video components.

Analog Video

There are three types of analog video connections: composite video, S-video and component video.

CONNECTIONS

Composite video is the basic connection most commonly available. The jack is usually color-coded yellow, and looks like an analog audio jack. Do not plug a composite video cable into an analog or coaxial digital audio jack, or vice versa. Both the chrominance (color) and luminance (intensity) components of the video signal are transmitted using a single cable. See Figure 10.



Figure 10 – Composite Video

S-video, or “separate” video, transmits the chrominance and luminance components using separate wires contained within a single cable. The plug on an S-video cable contains four metal pins, plus a plastic guide pin. Align the plug correctly when you insert it into the jack. See Figure 11.

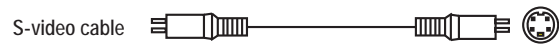

Figure 11 – S-Video

Component video separates the video signal into three components – one luminance (“Y”) and two sub-sampled color signals (“Pb” and “Pr”) – that are transmitted using three separate cables. See Figure 12.

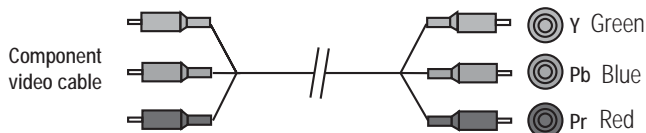

Figure 12 – Component Video

If it's available on your video display, an HDMI connection is recommended as the best quality connection, followed by component video, S-video and then composite video.

NOTES:

- Copy-protected sources are not available at the Component Video Monitor Outputs.
- Standard and high-definition analog video signals may be upscaled to 1080i resolution for the Component Video Monitor Outputs. For improved video performance, consider upgrading to an HDMI-capable video display with 1080p resolution.

ANTENNAS

The AVR 7550HD uses separate terminals for the included FM and AM antennas.

The FM antenna uses a 75-ohm F-connector. See Figure 13.

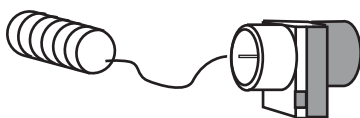

Figure 13 – FM Antenna

The AM loop antenna needs to be assembled. Connect the two leads to the spring terminals on the receiver. The AM antenna leads have no polarity, and you may connect them to either terminal. See Figure 14.

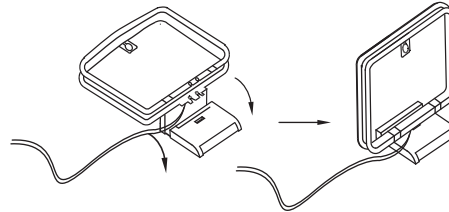

Figure 14 – AM Antenna

To enjoy XM satellite radio, purchase an XM Ready antenna module and a subscription to the XM service. The XM Mini Tuner and Home Dock Bundle, available at www.xmradio.com, is recommended. The older Connect-and-Play module is also compatible with the AVR 7550HD, but it may no longer be available. Although you may use a module with standard audio connections, labeled for “car and home use,” you will not be able to enjoy the AVR 7550HD's ease of control.

RS-232 SERIAL PORT

The RS-232 serial port may be connected to an external computer or control device to allow the external device to transmit control commands to the AVR. The port is bidirectional, so that the AVR can transmit status updates to the control device. Connecting and using the RS-232 port requires technical knowledge, and is best left to a professional custom installer.

INSTALLATION

You are now ready to begin installing the AVR. Before beginning to connect the various components to the receiver, turn off all devices, including the AVR 7550HD, and unplug their power cords. *Don't plug in any of the power cords until you have finished making all of your connections.*

The receiver generates heat. Select a location that leaves several inches of space on all sides. Avoid completely enclosing the receiver inside an unventilated cabinet. Place components on separate shelves rather than stacking them directly on top of the receiver. *Never block the AVR's ventilation slots on the top and side panels. Doing so could cause the AVR to overheat, with potentially serious consequences.* Some shelf surface finishes are delicate. Try to select a location with a sturdy surface finish.

TIP: Label each cable before connecting it, to avoid mistakes. Write a description of the cable on a blank adhesive label, e.g., "DVD", and fold the label around the cable about 6 inches from the end to be plugged into the AVR.

Almost all of the following installation steps are optional, depending on your system. Skip any step that does not apply to your system.

STEP ONE – Connect Source Devices

Leaving all AC power cords unplugged, connect the source devices to the AVR using the audio and video inputs you assigned in Table 2.

STEP TWO – Connect TV

Connect the system-best video input on the TV to the corresponding video monitor output on the AVR.

STEP THREE – Connect Loudspeakers

After you have placed your loudspeakers in the room as explained on page 21, connect each speaker to its color-coded terminal on the AVR. Maintain proper polarity by connecting the negative terminal on the speaker (usually colored black) to the negative terminal on the AVR (also colored black); and the positive terminal on the speaker (usually red) to the positive terminal on the AVR (color varies by channel; see Table 1 on page 18).

If you have a subwoofer, connect its line-level or LFE input to the purple Subwoofer 1 Output. An optional second subwoofer may be connected to the Subwoofer 2 Output.

NOTE: If the subwoofer only has speaker-level inputs, after you have configured the AVR using EzSet/EQ II technology as described on page 29, connect the subwoofer's left and right speaker input terminals to the AVR's Front Left and Front Right Speaker Outputs, then connect the front left and right main speakers to the subwoofer's left and right speaker output terminals. Consult the owner's manual for the subwoofer for specific installation instructions.

STEP FOUR – Connect ^{The}Bridge II Dock

To enjoy content stored on a compatible iPod (not included), connect The Bridge II dock (included) to its proprietary connector.

STEP FIVE – Connect FM Antenna

Connect the included FM antenna to the 75-ohm FM antenna terminal.

STEP SIX – Connect AM Antenna

Assemble the included AM antenna (see Figure 17) and connect it to the AM and Ground antenna terminals. The antenna is not polarized, and either lead may be connected to either terminal.

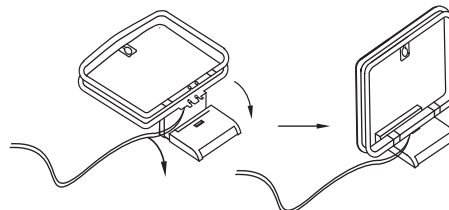

Figure 17 – AM Antenna Assembly

STEP SEVEN – Connect XM Antenna Module

If you have purchased an optional XM antenna module designed for XM Ready® devices, plug it into the XM jack. Purchase a subscription and activate the module, following the instructions posted at www.xmradio.com. Place the module within view of a south-facing window.

STEP EIGHT – Connect USB Device

To play MP3 or WMA audio files or JPEG still-image files stored on a USB storage device, connect the device to the front-panel USB Port, using a cable or connector that is attached to the device or provided by you.

STEP NINE – Connect AVR to Internet

To use the AVR's internal Internet Radio tuner to listen to MP3 or WMA audio streams, connect the Network Jack to the Ethernet port on a router or modem that has Internet access, a home network, or directly to a PC. You may need to contact your Internet service provider (ISP), or the manufacturer of your router, to obtain the information necessary to set up the network connection. See pages 36 and 37.

STEP TEN – Connect Remote IR Inputs and Outputs

The AVR 7550HD is equipped with a Remote IR Input, a Zone 2 Input and both full-carrier and stripped Remote IR Outputs to facilitate use of your system with a remote control in a variety of situations.

When the AVR 7550HD is placed inside a cabinet or facing away from the listener, connect an external IR receiver, such as the optional Harman Kardon HE 1000, to the Remote IR Input jack. For multizone operation, connect an optional IR receiver, keypad or other control device to the Zone 2 IR Input for remote control of the AVR 7550HD (and any sources connected to the AVR's Remote IR Output) from the remote zone. Signals transmitted through the Zone 2 IR Input will control source selection and volume for the main or remote zone, depending on the setting of the remote's Zone Selector. If a source device is shared with the main listening area, any control commands issued to that source will also affect the main room.

INSTALLATION

If any source devices are equipped with a compatible Remote IR Input, use a 1/8-inch mini-plug interconnect cable (not included) to connect the AVR's Remote IR Output to the source device's Remote IR Input.

The AVR 7550HD outputs a "stripped carrier" IR signal through the Remote IR Output, but a full-carrier IR signal is available at the Carrier Remote IR Output. The Carrier Remote IR Output is only available to one sender at a time, which is assigned in the AVR's Zone 2 menu. Depending on whether you select Zone 2, Front or A-BUS, the Carrier Remote IR will only transmit commands received from the Zone 2 IR Input, the front-panel IR receiver or the A-BUS system to a device connected to it. This avoids having conflicting control commands sent to a device from listeners in different areas of the home.

To control more than one source device through the Remote IR Output, connect all sources in "daisy chain" fashion, connecting each device's IR output to the next device's IR input, starting with the AVR. Connect devices expecting a full-carrier IR signal to the Carrier Remote IR Output, and assign the desired sending zone in the Zone 2 menu. Use the Remote IR Output for devices expecting a stripped signal.

STEP ELEVEN – Install a Multizone System

The AVR 7550HD offers several methods of distributing audio to other areas in your home, and it also features video distribution.

IMPORTANT SAFETY NOTE: Installing a multizone system typically requires running cables inside walls. Always comply with the appropriate safety codes when installing concealed wiring, particularly all applicable state and local building codes and the NEC (National Electrical Code). Failure to do so may present a safety hazard. If you have any doubt about your ability to work with electrical and telecommunications wiring, hire a licensed electrician or custom installer to install the multizone system.

When the system is installed using method B or C below, multizone operation takes over the Surround Back/Zone 2 amplifier channels, limiting the system in the main listening room to 5.2 channels.

Select one or all of these methods for audio distribution:

A. Connect an external amplifier to the Zone 2 Audio Outputs. It is recommended that you place the amplifier in the same room as the AVR 7550HD so that a shorter length of interconnect cable is used with a long run of speaker wire to the remote room. A long run of interconnect cable would be subject to signal degradation. Depending on your amplifier, distribute the audio signal to a single pair of speakers, or to several pairs placed in different rooms.

The Zone 2 Audio Outputs offer the benefit of 7.2-channel audio in the main room simultaneously with multizone operation. However, the benefit is achieved with the expense of an additional component, i.e., the amplifier.

B. Connect the remote room's speakers directly to the Surround Back/Zone 2 Speaker Outputs.

Reassign the Surround Back amplifier channels to power the speakers (see page 47).

Your main system will be limited to 5.2 channels, affecting playback of programs recorded in 6.1 or 7.1 channels.

C. Connect an external amplifier to the Surround Back/Zone 2 Preamp Outputs. This method requires an additional amplifier, but may increase the total number of remote rooms when used with methods A and B.

D. Connect an A-BUS hub or other A-BUS components to the A-BUS port. Use Category 5/5e cable, as described in the instructions for your A-BUS components. The A-BUS system carries the audio signal to the remote components, while receiving IR control codes. A hub may distribute audio to many remote rooms. To control source devices exclusively from the remote A-BUS module, connect the AVR's Carrier Remote IR Output to a compatible IR input on the source, and assign the full-carrier output to the A-BUS system in the AVR's Zone 2 menu. This avoids having conflicting control commands sent to a source intended for the A-BUS system.

IR commands received from the A-BUS system are also distributed to the AVR's other IR outputs. Visit the Web site at www.harmankardon.com for information on available Harman Kardon hubs, the ABH 4 and ABH 4000, and amplified in-wall modules, the AB 1 and AB 2.

Connect a Video Display Device or Switcher

To add video distribution to your multiroom system, connect the Multizone Video Output either directly to the video display in the remote room or to any optional video distribution switchers or amplifiers that may be required.

NOTES:

- Only composite video is output to the multizone system.
- S-video, component or HDMI video sources may not be routed through the multizone system. Make a second, composite video connection for the multizone system.
- When connecting the AVR 7550HD to the remote room's video display, distance limitations may exist for composite video connections. Although the use of low-loss coax cables may reduce signal loss, optional distribution amplifiers may occasionally be required when long cable runs are used.

Connect IR Control Devices to the Zone 2 IR Input

For methods A, B and C, connect an IR control device to the Zone 2 IR Input for remote-room control of the multizone system, source devices and volume in the remote zone. An A-BUS system does not require a separate IR control connection.

NOTE: Only analog audio sources are available to the multizone system. For digital sources, make a second, analog audio connection. The USB, The Bridge II and Internet Radio sources are available to the multizone system.

INSTALLATION

STEP TWELVE – Plug in AC Power Cords

Before plugging the AVR into an unswitched electrical outlet, make sure the Main Power Switch behind the front-panel door is off, to prevent the possibility of damaging the AVR in case of a transient power surge. When pressed in, the switch is on. When pressed again to unlatch it, the switch pops out.

You may plug one device that draws no more than 50 watts into the AC Switched Accessory Outlet on the rear panel. Turn on the device's mechanical or master power switch, and that device will power on any time the AVR 7550HD is turned on (some devices may require additional steps to power on from their standby mode). If the device has a clock or must always be on (such as a cable set-top box programmed to make recordings), do not plug it into this outlet.

The AVR 7550HD is equipped with a detachable power cord, allowing you to fully wire your system before installing the AVR. Plug the male end of the cord into an unswitched AC outlet, and the female end into the AVR 7550HD.

It is recommended that you copy the appropriate information from the Table 2 worksheet to Table A5 in the appendix for future reference, in the event changes are made to the system components.

STEP THIRTEEN – Insert Batteries in Remote

The AVR 7550HD remote control uses four AAA batteries (included).

To remove the battery cover located on the back of the remote, squeeze the tab and lift the cover.

Insert the batteries as shown in Figure 18, observing the correct polarity.



Figure 18 – Remote Battery Compartment

Point the remote's lens toward the front panel of the AVR 7550HD. Make sure no objects, such as furniture, are blocking the remote's path to the receiver. Bright lights, fluorescent lights and plasma video displays may interfere with the remote's functioning. The remote has a range of about 20 feet, depending on the lighting conditions. It may be used at an angle of up to 30 degrees to either side of the AVR.

Leave the Zone Selector Switch at the bottom in the Zone 1 position for normal use.

If the remote seems to operate intermittently, or if pressing a button on the remote does not cause the AVR Settings Button or one of the Source Selectors to light, check or replace the batteries.

STEP FOURTEEN – Program Sources Into the Remote

The AVR 7550HD remote may be programmed to control many brands and models of DVD players, cable boxes, satellite receivers,

the Harman Kardon DMC 1000 digital media center and TVs. It is also preprogrammed to operate your iPod when docked in The Bridge II.

To access the functions for a particular device, switch the remote's device mode. Press the AVR Settings Button to access the codes that control the receiver, or the Source Selector Buttons to access the codes for the devices programmed into the remote.

To program the codes for a source device into the remote:

1. Turn on the source device.
2. Access the remote's menu system by pressing and holding the AVR Settings Button for 3 seconds, until the "Main Menu" and "Program Device" messages appear in the LCD Display.
3. Press the OK Button to select the Program Device function.
4. Use the ▲/▼ Buttons to select the Source Selector (or device) to program, and press the OK Button when the desired device appears on the lower line of the LCD Display.
5. For two of the Source Selectors and for sources A, B, C and D, the next step requires you to specify the device type. For the other Source Selectors, proceed to step 6.
 - **Cable/SAT:** Use the ▲/▼ Buttons to select either a cable television or satellite television set-top box, and press the OK Button.
 - **AUX:** Use the ▲/▼ Buttons to select a CD player, HDTV set-top box, PVD (personal video device, such as a DVR), TiVo system or VCR. Press the OK Button when the desired device appears.
 - **A, B, C, D:** Select any desired device type.
6. Select whether to program the device manually or use the remote's Auto Search capability. Manual programming simply requires you to select the brand name of your device and try a handful of possible codes. There is no need to look up numeric codes; the AVR 7550HD does the work for you. It is recommended that you select Manual programming first.

• **Manual Programming:** Use the ▲/▼ Buttons to scroll through the list of brands for which the remote has codes stored in its library. When your brand appears on the lower line, press the OK Button.

The remote will look up the brand in its library and display the number of codes available. Press the "1" Alphanumeric Key first. The remote will transmit the Power Off command associated with the first code set to the device. If the device turns off, then a compatible code set has been found. Press the OK Button to accept it.

If the device remains powered on, press the "2" Alphanumeric Key. Proceed in this fashion until either a compatible code set is found, or you run out of codes for that brand.

If you run out of codes, press the Back/Exit Button to end the process, and repeat steps 2 through 5. At step 6, select Auto and follow the instructions in the next bullet.

• **Auto Programming:** Wait for the remote to retrieve its entire library of codes for the device type. You will have to press the ▲/▼ Buttons to transmit every code for the device type until a compatible code set is found.

INSTALLATION

- When a compatible code set is found, press the OK Button to program it into the Source Selector.
- Check that other functions control the device correctly. Sometimes manufacturers use the same Power code for several models, while other codes vary. Repeat this process until you've programmed a satisfactory code set that operates most functions.

To change the device type of a Source Selector:

If your system includes two products of one device type but no product corresponding to a different Source Selector, you may program one product into its corresponding Source Selector, and change another Source Selector's device type to program the second product by following this procedure:

- Access the remote's menu system by pressing and holding the AVR Settings Button for 3 seconds, until the "Main Menu" and "Program Device" messages appear in the LCD Display.
- Use the ▲/▼ Buttons to select "Change Device Type" from the remote's main menu, and press the OK Button.
- Use the ▲/▼ Buttons to select the Source Selector whose device type you wish to change, and press the OK Button. Your selection will appear on the left side of the lower line, while the choice of new device types will appear on the right side.
- Use the ▲/▼ Buttons to select the new device type you wish to assign to the Source Selector, and press the OK Button.
- Program your product into the Source Selector by choosing the brand, then searching for a compatible code set, as described in the preceding section. If you allow the remote to "time out", then the device type reassignment will not take effect.

To "learn" individual key codes:

If some functions do not work correctly, you may reprogram individual keys from the device's original remote by following this procedure:

- Place the two remotes with their IR transmitters facing each other, about one inch apart. See Figure 19.



Figure 19 – AVR and Device Remotes "Head to Head"

- Access the remote's menu system by pressing and holding the AVR Settings Button for 3 seconds, until the "Main Menu" and "Program Device" messages appear in the LCD Display.
- Use the ▲/▼ Buttons to select "Learn" from the remote's main menu, and press the OK Button.
- When the "Learn Menu" message appears in the upper line of the LCD Display, make sure the "Learn" message appears in the lower line (not "Learn Delete"), and press the OK Button.
- Use the ▲/▼ Buttons to select the device you wish to learn a code for, and press the OK Button.
- Press the destination button, and the menu will prompt you to press the key on the original remote whose code you wish to program into the destination button. You may learn a new code into the following buttons: Device Power On/Off, Alphanumeric Keys, Last Button, Back/Exit Button, Menu Button, Navigation

Buttons, OK Button, Disc Menu Button, the four Soft Keys, Channel Up/Down, Volume Up/Down, Mute and the Transport Controls (including Record).

NOTE: If you press the wrong destination button and wish to cancel the learning process, you must wait about 30 seconds for the remote to "time out". It will exit its program mode and return to normal operation, and you may begin again. Pressing another button will have no effect.

- Press the key on the original remote, and if the code was learned correctly, the Navigation and OK Buttons will light up. The Learn Menu will prompt you to learn another key, rename the key just learned or exit Learn mode. Use the ▲/▼ Buttons to make your selection, and press the OK Button.

To delete a programmed or learned code:

- Access the remote's menu system by pressing and holding the AVR Settings Button for 3 seconds, until the "Main Menu" and "Program Device" messages appear in the LCD Display.
- Use the ▲/▼ Buttons to select "Learn" from the remote's main menu, and press the OK Button.
- When the "Learn Menu" message appears in the upper line of the LCD Display, scroll to the "Learn Delete" option, and press the OK Button.
- The Learn Delete menu offers the options of deleting a single learned key code, an entire device or all devices. Scroll to the desired option and press the OK Button.
 - To delete an individual key code, the remote will first prompt you to select the device containing the key code, then prompt you to press the key. It will confirm the deletion, then offer you the opportunity to delete another learned key or exit the delete key function.
 - To delete an entire device, the remote will prompt you to select the device. When you scroll to the device and press the OK Button, the remote will confirm the deletion and exit its programming mode, returning to normal operation.
 - To delete all devices, wait a few moments while the remote deletes all programmed device codes. It will then return to normal operation.

To rename a key or device:

If you wish to change the name of a device or key as it appears in the LCD Display, follow these steps:

- Access the remote's menu system by pressing and holding the AVR Settings Button for 3 seconds, until the "Main Menu" and "Program Device" messages appear in the LCD Display.
- Use the ▲/▼ Buttons to select "Rename" and press the OK Button.
- Use the ▲/▼ Buttons to select whether to rename a device or a key, and press the OK Button.
- Use the ▲/▼ Buttons to select the device, either to rename the device itself or a key function used by that device, and press the OK Button.
- The current name of the device or key will appear on the lower line of the LCD Display, with the cursor at the end of the line.

INSTALLATION

Use the ◀ Button to move the cursor to the beginning of the name, then type over the current name using the Alphanumeric Keys.

Each Alphanumeric Key has the characters available in addition to its number printed above the key. Each press of the key scrolls through the available characters. To move to the next character, either press the ▶ Button or press the next desired Alphanumeric Key.

Press the OK Button to finish, and the remote will prompt you to rename another key or device, or to exit.

STEP FIFTEEN – Turn On the AVR 7550HD

Two steps are required the first time you turn on the AVR 7550HD.

1. Flip down the Front-Panel Door and press the Main Power Switch in. The Power Indicator on the front panel will turn amber, indicating that the AVR is in Standby mode and is ready to be turned on. Normally, you may leave the Main Power Switch on, even when the receiver is not being used.
2. There are several ways to turn on the AVR from Standby mode.
 - a) Press the Standby/On Switch on the front panel.
 - b) Using the remote, press the AVR Power On Button or any of the Source Selectors.

NOTES:

- Any time you press one of the Source Selectors on the remote, the remote will switch device modes. To control the receiver, press the AVR Settings Button. Some AVR functions are available in all device modes: Volume Controls (including Mute), Audio Effects, Video Modes, Surround Modes, AVR Settings, Info Settings, Sleep Settings and AVR Power On and Off.
- If you do not see a picture within about 1 minute, refer to the Video Troubleshooting Tips on page 34.

OPERATION

Now that you have installed your components and completed a basic configuration, you are ready to begin enjoying your home theater system.

TURNING ON THE AVR 7550HD

Flip down the Front-Panel Door and press the Main Power Switch in. The Power Indicator on the front panel will turn amber, indicating that the AVR is in Standby mode and is ready to be turned on. The Main Power Switch is normally left on.

There are several ways to turn on the AVR 7550HD:

- Press the Standby/On Switch on the front panel.
- Using the remote, press the AVR Power On Button or any of the Source Selectors.

To turn the receiver off, press either the Standby/On Switch on the front panel or the AVR Power Off Button on the remote. Unless the receiver will not be used for an extended period of time, leave the Main Power Switch on. When the Main Power Switch is turned off, any settings you have programmed will be preserved for up to four weeks.

IMPORTANT NOTE: If the PROTECT message ever appears in the Message Display, turn off the AVR and unplug it. Check all speaker wires for a short. If none is found, bring the unit to an authorized Harman Kardon service center for inspection and repair before using it again.

VOLUME CONTROL

Adjust the volume either by turning the knob on the front panel (clockwise to increase volume or counterclockwise to decrease volume), or by pressing the Volume Control on the remote. The volume is displayed as a negative number of decibels (dB) below the 0dB reference point.

0dB is the maximum recommended volume for the AVR 7550HD. Although it's possible to turn the volume to a higher level, doing so may damage your hearing and your speakers. For certain more dynamic audio materials, even 0dB may be too high, allowing for damage to equipment. Use caution with regard to volume levels.

To change the volume level display from the default decibel scale to a 0-to-90 scale, adjust the Volume Units setting in the System Settings menu, as described on page 48.

Dolby Volume

The AVR 7550HD is one of the first products to implement Dolby Volume processing, which can improve the audio performance of the system by revealing subtle details even at normal home-listening volumes.

One concern of the typical home theater listener is that volumes can vary widely for different programs played by a source, e.g., television commercial advertisements are often much louder than the main feature. Another is that details heard in the recording studio at typically high reference volumes are lost at the lower volumes used by many listeners.

The AVR 7550HD uses two Dolby Volume techniques to address these issues. The Leveler module maintains a consistent listening volume within a source, e.g., while watching commercial television

or while listening to different tracks on a USB drive. The Modeler module endeavors to re-create the reference presentation that was heard in the recording studio without losing portions of the program at the typically lower volume levels often used in the home. When the Modeler module is active, you may notice details of the performance that were hidden when the program was played on other equipment.

NOTE: The Dolby Volume processor is not used to level volume across sources. If one source sounds significantly louder or softer than the others, compensate by adjusting the Input level from source setting in the Info Settings menu for the source.

To adjust the Dolby Volume setting, press the Audio Effects Button. A screen similar to the one shown in Figure 24 will appear. Move the cursor to highlight the Dolby Volume setting, and each press of the OK Button will switch to one of the options in Table 3 below. The settings do not refer to the volume level, which is adjusted normally using the Volume Control, but rather to the amount of Dolby Volume processing desired. See Figure 24.



Figure 24 – Adjust Dolby Volume

Table 3 – Dolby Volume Settings

Setting	Effect
Off	No Dolby Volume processing
Low	Only Dolby Volume Modeler module is active
Medium	Both Modeler and Leveler modules are active; Leveler module has a value of 3
Max	Both Modeler and Leveler modules are active; Leveler module has a value of 9

NOTE: Dolby Volume is compatible with sources recorded at a sampling rate of 48kHz. High-resolution sources, such as DTS 96/24, will be decoded at 48kHz. DTS 96/24 programs will be played in DTS 5.1 mode. To hear DTS 96/24 materials in high resolution, turn off Dolby Volume.

Dolby Volume Calibration Offset

Calibration Offset is a feature of Dolby Volume that allows you to adjust the calibration of the AVR 7550HD to optimally match your speakers and listening environment. The AVR 7550HD is calibrated with the average speaker sensitivity in mind; however, different speakers may have different sensitivities. Use Calibration Offset to adjust the calibration of the AVR 7550HD according to the types of speakers you have.

OPERATION

The average home audio speaker sensitivity is 88dB SPL (8 ohms, 1 watt, 1 meter). Check the sensitivity specification for your loudspeakers, found in the owner's manual or on the manufacturer's Web site. If your speakers have a sensitivity rating greater than 88dB SPL, increase Calibration Offset by the difference between your speakers' sensitivity and 88dB. If they have a sensitivity rating of less than 88dB SPL, decrease Calibration Offset by the difference between your speakers' sensitivity and 88dB.

To adjust the Calibration Offset, press the AVR Settings Button and scroll to the System Setup menu, then select it. Scroll to the Dolby Volume Calibration line, which defaults to 0dB. Use the ◀/▶ Buttons to adjust the setting within the range of -10dB to +10dB.

MUTE FUNCTION

To temporarily mute all speakers and the headphones, press the Mute Button on the remote. Any recording in progress will not be affected. The MUTE message will appear in the display as a reminder. To restore normal audio, press the Mute Button again, or adjust the volume. Turning off the AVR will also end muting.

SLEEP TIMER

The sleep timer sets the AVR to play for up to 90 minutes and then turn off automatically.

Press the Sleep Settings Button on the remote, and the time until turn-off will be displayed. Each additional press of the Sleep Button decreases the play time by 10 minutes, with a maximum of 90 minutes. The SLEEP OFF setting disables the sleep timer.

When the sleep timer has been set, the front-panel display will automatically dim to half-brightness and the Volume Control will go dark.

If you press the Sleep Button after the timer has been set, the remaining play time will be displayed. Press the Sleep Button again to change the play time.

AUDIO EFFECTS

Adjust the Dolby Volume setting, tone controls, LFE trim or equalization, or select a speaker configuration to improve performance. Access these settings from the Audio Effects submenu, as described in the Advanced Functions section.

It is recommended that you leave the settings at their default values until you are more familiar with your system.

VIDEO MODES

The settings in the Video Modes menu are used to fine-tune the picture, if necessary, after making all adjustments on the video display. It is recommended that you leave the settings at their defaults. See the Advanced Functions section for detailed information.

HEADPHONES

Plug the 1/4"-inch plug on a pair of headphones into the jack behind the front-panel door for private listening. The default Dolby Headphone bypass mode delivers a conventional 2-channel signal to the headphones.

Press the Surround Modes Button on the front panel or the remote, to switch to Dolby Headphone virtual surround processing, which

emulates a 5.1-channel speaker system. No other surround modes are available for the headphones.

SOURCE SELECTION

Press the front-panel Source List Button. Use the ▲/▼ Buttons to scroll through the sources. Using the on-screen menus, press the AVR Settings Button, highlight "Source Select" and press the OK Button. Scroll to the desired source in the slide-in menu and press the OK Button.

For direct access to any source, press its Source Selector on the remote. To directly select Source A, B, C or D, first press the AVR Settings Button, then press the appropriate Soft Key: red for Source A, green for Source B, yellow for Source C or blue for Source D. When using the Zone 2 remote, make sure to connect the Zone 2 Video Output to a display in the remote zone, and select these sources using the on-screen menu system.

The AVR selects the audio and video inputs assigned to the source, and any other settings made during setup.

The source name, the audio and video inputs assigned to the source, and the surround mode will appear on the front panel. The source name and surround mode will also appear on screen.

VIDEO TROUBLESHOOTING TIPS:

If there is no picture:

- Check the source selection and video input assignment.
- Check the wires for a loose or incorrect connection.
- Check the video input selection on the display device (TV).
- Press the front-panel Resolution Button and use the ▲/▼ Buttons until the correct video output resolution is selected and a picture appears. The CANCEL message will appear. Press the ▼ Button to view the ACCEPT option, then press the OK Button.

Additional Tips for HDMI Connections:

- Turn off all devices (including the TV, AVR and any source components).
- Unplug the HDMI cables, starting with the cable between the TV and AVR, and continuing with the cables between the AVR and each source device.
- Carefully reconnect the cables from the source devices to the AVR. Connect the cable from the AVR to the TV last.
- Turn on the devices in this order: TV, AVR, source devices.

USING THE TUNER

To select the AVR 7550HD's built-in tuner:

1. Press the Source List Button on the front panel. Use the ▲/▼ Buttons to scroll to the desired tuner band.
2. Press the Radio Source Selector on the remote. Press it again to switch bands (AM, FM or XM).

A screen similar to the one shown in Figure 25 will appear. The XM band uses a different screen.

OPERATION



Figure 25 – FM Radio

Use the ▲/▼ Buttons or the Channel Control to tune a station (or channel for XM Radio), as displayed on the front panel and on screen.

The AVR defaults to automatic tuning, meaning each press of the ▲/▼ Buttons scans through all frequencies until a station with acceptable signal strength is found. To switch to manual tuning, in which each press of the ▲/▼ Buttons steps through a single frequency increment (0.1MHz for FM, or 10kHz for AM), press the Menu Button. The Mode line will display the current setting. Each press of the OK Button toggles between automatic and manual tuning modes.

When an FM station has been tuned, toggling the tuning mode also switches between stereo and monaural play, which may improve reception of weaker stations.

A total of 30 stations (AM and FM together) may be stored as presets. When the desired station has been tuned, press the OK Button, and two dashes will flash in the front-panel display. Use the Alphanumeric Keys to enter the desired preset number.

To tune a preset station, press the ◀▶ Buttons or the ◀◀▶▶ Transport Controls, or press the Menu Button and scroll to the desired preset, then press the OK Button; or enter the preset number using the Numeric Keys. For presets 10 through 30, press 0 before the preset number. For example, to enter preset 21, press 0-2-1.

XM RADIO OPERATION

To listen to Satellite Radio, you'll need to connect an XM Satellite Radio tuner (sold separately) to your XM Ready receiver. XM Satellite Radio is available to residents of the U.S. (except Alaska and Hawaii) and Canada.

Satellite Radio delivers a variety of commercial-free music from categories including Pop, Rock, Country, R&B, Dance, Jazz, Classical and many more, plus coverage of all the top professional and college sports, including play-by-play games from select leagues and teams. Additional programming includes expert sports talk, uncensored entertainment, comedy, family programming, local traffic and weather, and news from your most trusted sources.

Once you've purchased an XM tuner, you'll need to activate and subscribe to begin enjoying the service. Easy-to-follow installation and setup instructions are provided with the satellite tuners. There are a variety of programming packages available, including the option of adding "The Best of SIRIUS" programming. ("The Best of SIRIUS" service is not available to XM Canada subscribers at this time.)

Family-friendly packages are also available to restrict channels featuring content that may be inappropriate for children.

To subscribe to XM, U.S. customers should visit xmradio.com or call 1-800-XMRADIO (1-800-967-2346); Canadian customers should visit xmradio.ca or call XM Listener Care at 1-877-GETXMSR (1-877-438-9677).

The AVR 7550HD is an XM Ready device, and is able to receive the XM service when a user-supplied XM antenna module is connected and the service activated.

Select an antenna module designated for XM Ready audio components. An XM Ready module uses the special connector on the AVR and is controlled by the AVR's tuner, including its 40 preset station locations and remote control. Although you may use a "car and home" module with standard audio connections, you will not be able to enjoy the AVR's ease of control.

The XM Mini-Tuner and Home Dock (Models CNP-2000 and CNP-2000H; both pieces are required) are compatible with the AVR 7550HD. The older Audiovox® CNP 1000 "Connect-and-Play" module for home audio use is also compatible, but has been discontinued. Other modules that have standard analog or digital audio outputs may be connected to a compatible input and operated using their own controls.

Plug the module into the XM Antenna Jack on the rear of the AVR 7550HD. Place the antenna module so that it has a clear view through a south-facing window.

Select XM Radio as the source in one of these ways:

1. Press the Source List Button on the front panel. Use the ▲/▼ Buttons to scroll to "XM Radio" and press the OK Button.
2. Press the Radio Source Selector on the remote repeatedly until XM Radio is selected.

There are four ways to tune an XM Radio channel:

1. Use the ▲/▼ Buttons or the Channel Control to scan through the channel numbers.
2. Use the ◀▶ Buttons to scan through any previously programmed preset stations.
3. After you have programmed presets, directly enter the preset number (1 through 40) using the Alphanumeric Keys. For two-digit positions, enter a "0" before the number.
4. Press the Menu Button to search for a channel by: preset, category, all channels or direct entry.

When you are able to hear Channel 1, you are ready to activate your module. If you don't hear Channel 1, make sure the module's plug is firmly seated in the XM Antenna jack, and that the module is near a south-facing window. Try unfolding the module and rotating it to obtain reception. You may need to purchase an extension cable to ensure that the module is near the window.

Tune to Channel 0 for a display of your module's Radio ID number. You may also view the Radio ID number by pressing the Menu Button and selecting "XM Setting".

The current channel number and preset location will appear in the upper line of the Message Display, and the channel name will appear in the lower line. Three signal-strength bars will appear to the right of the channel number and preset location. The song title, artist and channel category, along with the channel number and preset position (if programmed), will all appear on screen when a video display is in use.

OPERATION

For traffic and weather channels, the current city's name will appear instead of the channel name, and the local weather and temperature will be displayed on screen.

To store a channel in one of the 40 preset locations:

1. Tune to the desired channel and press the OK Button. Two dashes will flash.
2. Use the Alphanumeric Keys to enter the numbered preset location you wish to store the channel in. For two-digit numbers, enter a "0" before the number.
3. After you have programmed presets, directly enter the preset number (1 through 40) using the Alphanumeric Keys. For two-digit positions, enter a "0" before the number.

USB PLAYBACK

To enjoy audio and still-image playback of media stored on a USB flash drive, connect the drive to the front-panel USB Port and select the USB source on the AVR. Press the Menu Button and select "Browse USB". The AVR will list the folders and files of audio and still-image content. Do not connect a personal computer or peripheral to the USB Port. USB hubs and multi-card readers are not supported.

IMPORTANT NOTE: The AVR 7550HD's internal processor requires about 10 seconds to detect, recognize and connect to a USB device. Please wait 10 seconds after inserting a device or switching the USB source before attempting to browse the device. If you try to browse the device sooner, the AVR may not display the device's contents correctly in the on-screen slide-in menu. If that happens, remove the device and reinsert it into the USB Port, then wait 10 seconds before browsing. Always stop playback before removing a USB drive, and wait at least 10 seconds before inserting another drive.

- To expand a folder, press the OK Button or the ► Navigation Button.
- To collapse a folder or return to the previous menu level, press the Back/Exit Button or the ◀ Button.
- To play all audio or still-image files within a folder, select the folder and press the OK Button or the Play Button.
- To skip to the next track or image, press the ► Navigation Button.
- To return to the beginning of the current track, press the ◀ Button once; to return to the previous track, press the ◀ Button twice. When displaying images, pressing the ◀ Button returns to the previous image.
- The Transport Controls may be used to control playback for skipping to the previous or next track, searching at high speed forward or backward within a track, playing a file, pausing playback or stopping playback.
- To repeat a file or folder, press the Menu Button and select the Repeat option. Each press of the OK Button will change the setting from Off (no repeat) to Repeat One (file) to Repeat All (files at the current directory level of the drive). Repeat All will always be activated when Random Music playback is turned on.
- To play the audio tracks in random order, press the Menu Button and select the Random Music setting. Each press of the OK Button turns the setting on or off. The AVR will automatically repeat the tracks until playback is stopped manually.

- To view the still images in random order, press the Menu Button and select the Random Photos setting. Each press of the OK Button turns the setting on or off.
 - To view a slideshow of images, select a folder containing the images for playback. You may also select audio files stored on the same device for playback as background music to the slideshow. Select the audio file, then the image files.
 - When both music and a slideshow are playing, if the slide-in menu is not displayed, press the ◀/▶ Buttons to skip to the next picture or return to the previous picture. When the slide-in menu is displayed, press the ◀/▶ Buttons to skip to the next or previous audio track.
 - While an image is being displayed, each press of the ▲ Button rotates the image 90° clockwise, and each press of the ▼ Button rotates the image 90° counterclockwise.
 - To change the duration of each image on screen during a slideshow, press the Menu Button and select the Slideshow Speed setting. Each press of the OK Button changes the speed: Slow, Medium or Fast.

INTERNET RADIO

With its network connection, the AVR 7550HD opens a world of MP3- and WMA-format streams when Internet access is available. Connect the RJ-45 Network jack on the AVR to an Ethernet port on a home-network router. Turn on the AVR and the video display, and press the Network Selector on the remote. Each press toggles between the Network Now Playing and Internet Radio screens.

With the Internet Radio screen displayed, the AVR will automatically connect to the Internet via the www.radioharmankardon.com portal. To select a stream, press the Menu Button, and use the ▲/▼ Buttons to search by category: Presets, Favourites, Location, Genre, New Stations, Most Popular or Podcasts.

To create a Favourites list, log onto www.radioharmankardon.com from your PC. Enter the ID # of your AVR 7550HD (found by pressing the Menu Button and selecting "Network Setup") and create an account. Favourites that you select on the Web site will be available on the AVR.

Navigation is similar to other slide-in menus. Scroll to the desired item and press the OK Button or the ► Button to select it. To return to the previous menu level (or to clear the menu from view from the top level), press the Back/Exit Button or the ◀ Button.

If you know the URL (Uniform Resource Locator, or Web address) of a specific audio stream, select the Direct Station option from the menu. The AVR 7550HD is not able to connect to streams that require site registration or other interaction prior to playing the stream. A live stream is required. If the AVR cannot connect to the stream, the "Station Not Live" message will appear briefly, and the Internet Radio screen will remain essentially blank. Not all URLs will be accessible.

Up to 30 preset Internet Radio stations may be programmed. To set a preset, first tune the station. Press the OK Button, and two dashes will flash. Enter the preset number using the Alphanumeric Keys. The connection to the station will momentarily stop, interrupting the program, and the AVR will reconnect to the station.

To connect to a station programmed as a preset, enter its preset number using the Alphanumeric Keys, or select from the previously programmed presets using the ◀/▶ Buttons.

OPERATION

NOTES ON NETWORK SETUP:

- It is recommended that the AVR be connected to a home-network router so that it can directly access the Internet for Internet Radio, or access a PC on the network for playback of content stored on the PC (see the Network Playback section below).
- If you are unable to connect to the Internet, try adjusting the network settings. Press the Menu Button and select Network Setup. The Network Settings line will be highlighted. Each press of the OK Button toggles between Manual and Automatic network setup. Select Manual, and the other network settings will be displayed: IP Address, Subnet Mask, Gateway, Primary DNS, Secondary DNS, Proxy Address and Proxy Port. Contact your ISP (Internet Service Provider) for the correct information to enter into these settings. To change a setting, highlight it and press the OK Button. Use the ◀/▶ Buttons to move the cursor from one position to the next, and scroll to the desired number using the ▲/▼ Buttons. Press the OK Button when you are finished with an entry. Scroll down to the “Apply and Save” Button and select it. The AVR will turn off and must be powered back on. To return to the previous menu screen, press the Back/Exit Button.

NETWORK PLAYBACK

The AVR 7550HD is capable of playing audio media stored on a PC when both the PC and the AVR are connected to a home-network router.

NOTES:

- The PC must be running Windows Media® Player version 11 or higher, Windows Media Center version 2.0 or 3.0, or Intel® Media Server. It is recommended that any firewalls be turned off, although Windows Media Player may automatically make any necessary adjustments to the firewall settings to allow media sharing.
- An Apple Macintosh computer must be running DLNA (Digital Living Network Alliance)-compliant software. Examples of compatible software include the MediaLink program by Nullriver, Inc., and EyeConnect™ software by Elgato Systems.

From the media player software, select the “Share media” option (or a similar menu option), and select the AVR as the device.

On the AVR, select Network as the source. Press the Network Source Selector a second time, if necessary, to switch from the Internet Radio source to the Network source. Press the Menu Button, and the PC should appear by name.

Browse the content stored in the PC’s media player library, using the slide-in menu. Scroll to the desired item and press the OK Button or the ▶ Navigation Button to select it. To return to the previous menu level (or to clear the menu from view from the top level), press the Back/Exit Button or the ◀ Button.

NOTES:

- The Repeat, Random and Slideshow Speed settings are global for Network Playback and USB Playback. Changing these settings for one of these sources will have the same effect for the other source.

- Although video content may appear in the menu, the AVR does not support video playback from the network connection.

RECORDING

Two-channel analog and digital audio signals, as well as composite and S-video signals, are normally available at the appropriate recording outputs. To make a recording, connect your audio or video recorder to the appropriate output jacks, as described in the Installation section, insert blank media and make sure the recorder is turned on and recording while the source is playing.

NOTES:

1. Analog and digital audio signals are not converted to the other format.
2. Only PCM digital audio signals are available for recording. Proprietary formats such as Dolby Digital and DTS may not be recorded using the digital audio connections. Use the analog audio connections to make an analog recording.
3. HDMI and component video sources are not available for recording.
4. Please make certain that you are aware of any copyright restrictions on any material you record. Unauthorized duplication of copyrighted materials is prohibited by federal law.

USING ^{The Bridge II} DOCKING STATION

The Bridge II is an included dock that is compatible with most docking iPod models, 4G and later (not included). When The Bridge II is connected to its proprietary input on the AVR 7550HD and the iPod is docked, you may play the audio, video and still-image materials on your iPod through your high-quality audio/video system, operate the iPod using the AVR remote or the AVR’s front-panel controls, view navigation messages on the AVR’s front panel or a connected video display, and charge the iPod.

When the source The Bridge is selected and an iPod is docked, the message “The Bridge” appears in the front-panel Message Display. If the AVR doesn’t detect the iPod, turn off the AVR, remove the iPod from The Bridge II and reset the iPod. When the iPod returns to its main menu, redock it and turn on the AVR.

Table 4 summarizes the controls available with The Bridge II during normal playback.

Table 4 – Using The Bridge II

iPod Function	Remote Control Key
Play	Play (▶)
Pause	Pause ()
Menu	Menu
Back/Exit	Back/Exit or Left Arrow (◀)
Select	OK or Right Arrow (▶)
Scroll Reverse	Up Arrow (▲)
Scroll Forward	Down Arrow (▼)
Forward Search	Forward Search (▶▶)
Reverse Search	Reverse Search (◀◀)
Next Track	Next (▶▶) or Right Arrow (▶)
Previous Track	Previous (◀◀) or Left Arrow (◀)
Page Up/Down	Page Up/Down
Stop	Stop (■)

OPERATION

Press the Menu Button to view the slide-in menu:

Music: Navigates the audio materials stored on the iPod.

Photo/Manual: Select this line to view still images stored on a photo-capable iPod. The system will switch to iPod Manual Mode, and control will shift to the iPod. Use the screen and controls on the iPod. The AVR remote may also be used.

To view photos on a video monitor connected to the AVR, select the photo and press the Play Button on the iPod, or press the OK Button on the remote three times.

Videos: Select this line to view videos stored on an iPod that supports video browsing.

NOTES ON VIDEO PLAYBACK:

- As of this writing, video browsing is only supported on the iPod 5G, iPod classic (80GB, 120GB and 160GB), iPod nano 3G and 4G, and iPod touch (when loaded with software version 2 or higher). For other iPod models, it is not possible to view photos (except iPod 4G) or videos on an external monitor while using The Bridge II.
- Before attempting to view photos or videos stored on your iPod, check the Video Settings menu on the iPod and make sure that the TV Out setting is set to On. The TV Signal setting should be NTSC, to match the capabilities of your video display. If your selection was playing and is paused, the iPod requires you to reselect the video for the new TV Out setting to take effect.
- If you do not see the Videos line in the menu, and the iPod supports video browsing and has video content stored on it, you may need to turn off the AVR, remove the iPod from The Bridge II, reset the iPod, turn the AVR back on and dock the iPod again. This procedure may also help when a video program is selected but the "Now Playing" screen appears instead of the video images.

To exit iPod Manual Mode, with the AVR remote in The Bridge mode, press the Menu Button. To return to a previous menu level on the iPod, press the Back/Exit Button.

Random: Select this setting for random playback, also known as "Shuffle Mode". Each press of the OK Button switches the setting: shuffle by Song, shuffle by Album, or Off to end random playback.

Repeat: Select this setting to repeat a track or all tracks in the current album or playlist. Each press of the OK Button switches the setting: repeat Off, repeat One or repeat All.

NOTE: The iTunes application allows you to exempt some tracks from Shuffle mode. The AVR 7550HD cannot override this setting.

While a selection is playing, the song title and play mode icon will appear in the front-panel Message Display.

If a video monitor is connected to the AVR 7550HD and the system is not in iPod Manual Mode, the Now Playing screen will appear and display the play mode icon, song title, artist and album. A graphic bar indicates the current play position within the track. If random or

repeat play has been programmed, an icon will appear in the upper right corner.

The screen may disappear from view, depending on the Setup and Slide-In Menus setting in the System Settings menu (described in the Advanced Functions section). Restore the Now Playing screen to view by pressing either of the ◀/▶ Buttons.

NOTE: It is strongly recommended that you use the screen saver built into your video display to avoid possible damage from "burn-in" that may occur with plasma and many CRT displays when a still image, such as a menu screen, remains on display for an extended period of time.

iPod MANUAL MODE

Press the Menu Button and select Photo/Manual to enter iPod Manual Mode. This is required to view photos stored on the iPod.

Table 5 summarizes the controls available with The Bridge II in iPod Manual Mode.

Table 5 – Using The Bridge II in iPod Manual Mode

iPod Function	Remote Control Key
Play	Play (▶)
Pause	Pause (II)
Menu	Back/Exit or Left Arrow (◀)
Select	OK
Select Next Screen (Scrubber, Cover Art, Ratings)	Right Arrow (▶)
Scroll Reverse	Page Up or Up Arrow (▲)
Scroll Forward	Page Down or Down Arrow (▼)
Next Track	Next (▶▶I)
Previous Track	Previous (I◀◀)

The AVR supports audio playback from some applications available for the iPod touch. Place the system in iPod Manual Mode by pressing the Menu Button and selecting "Photo/Manual". Then use the controls on the iPod touch to run the application. Due to the wide variety of applications and many factors affecting them, playback is not guaranteed.

While scrolling, hold the key to scroll faster. Use the Page Up/Down control on the remote to scroll a page at a time (not in Manual Mode).

NOTES:

- The Play and Pause functions are not available unless content has been selected for playback.
- To search within a track (not in Manual Mode), press and hold the indicated button. Press the Previous Track Button once to skip to the beginning of the current track. Press the Previous Track Button twice to skip to the beginning of the previous track.

When a slideshow is being displayed, some controls have different effects:

- To pause the slideshow, including any audio track that is playing, press the Pause Button.

OPERATION

- To resume a paused slideshow, press the Pause Button. Pressing the Play Button begins audio playback.
- To play an audio track stored on the iPod, adjust the slideshow settings on the iPod.
- To skip to the next or previous photo on the iPod, press the Next or Previous Transport Control.
- It is not possible to skip to the next or previous audio track during a slideshow.
- To search forward or in reverse within an audio track, press the Forward or Reverse Search Transport Control. If no audio track is playing, these controls will have no effect during the slideshow.

SELECTING A SURROUND MODE

Surround mode selection can be as simple or sophisticated as your individual system and tastes. Feel free to experiment, and you may find a few favorites for certain sources or program types. More detailed information on surround modes may be found in the Advanced Functions section.

To select a surround mode, press the Surround Modes Button (front panel or remote). The Surround Modes menu will appear (see Figure 26). Use the ▲/▼ Buttons until the desired surround mode category appears: Auto Select, Virtual Surround, Stereo, Movie, Music or Video Game. Press the OK Button to change the audio type's surround mode.



Figure 26 – Surround Modes Menu

Auto Select: For digital programs, such as movies recorded with a Dolby Digital soundtrack, the AVR will automatically use the native surround format. For 2-channel analog and PCM programs, the AVR uses Logic 7 Movie, Music or Game mode, depending on the source.

Virtual Surround: When only two main speakers are present in the system, Dolby Virtual Surround may be used to create an enhanced soundfield that virtualizes the missing speakers. Select between Wide and Reference modes.

Stereo: When 2-channel playback is desired, select the number of speakers used for playback:

- 2 CH STEREO uses only two speakers. As described on page 40, you may select Analog Bypass mode for a pure analog signal when analog audio inputs are in use. Turn off the Tone Control setting in the Audio Effects submenu, and the AVR does the rest.
- 5 CH STEREO plays the left-channel signal through the front and surround left speakers, the right-channel signal through the right speakers and a summed mono signal through the center speaker.

- 7 CH STEREO follows the same scheme as 5 CH STEREO, but adds the surround back speakers. This mode is only available when the surround back speakers are present and have not been reassigned to multizone operation. See page 47 for more information.

Movie: Use when a surround mode is desired for movie playback: Logic 7 Movie, DTS Neo:6 Cinema or Dolby Pro Logic II (IIX when seven main speakers are present).

Music: Use when a surround mode is desired for music playback: Logic 7 Music, DTS Neo:6 Music or Dolby Pro Logic II (IIX when seven main speakers are present). The Dolby Pro Logic II/IIX Music mode allows access to a submenu with some additional settings. See the Advanced Functions section for more information.

Video Game: Use to select a surround mode for game playback: Logic 7 Game, or Dolby Pro Logic II (IIX when seven main speakers are present) Game.

After you have made your selection, press the Back/Exit Button.

See the Advanced Functions section for more information on surround modes.

TROUBLESHOOTING GUIDE

SYMPTOM	CAUSE	SOLUTION
Unit does not function when Main Power Switch is turned on	<ul style="list-style-type: none"> No AC Power 	<ul style="list-style-type: none"> Make certain AC power cord is plugged into a live outlet Check whether outlet is switch-controlled
Display lights, but no sound or picture	<ul style="list-style-type: none"> Intermittent input connections Mute is on Volume control is down 	<ul style="list-style-type: none"> Secure all input and speaker connections Press Mute Button Turn up volume control
No sound from any speaker; PROTECT message appears on front panel	<ul style="list-style-type: none"> Amplifier is in protection mode due to possible short Amplifier is in protection mode due to internal problems 	<ul style="list-style-type: none"> Check speaker wires for shorts at receiver and speaker ends Contact your local Harman Kardon service center
No sound from surround or center speakers	<ul style="list-style-type: none"> Incorrect surround mode Input is monaural Incorrect configuration Stereo or Mono program material 	<ul style="list-style-type: none"> Select a mode other than Stereo There is no surround information from mono sources Check speaker configuration The surround decoder may not create center- or rear-channel information from nonencoded programs
Unit does not respond to remote commands	<ul style="list-style-type: none"> Weak batteries in remote Wrong device selected Remote sensor is obscured 	<ul style="list-style-type: none"> Change remote batteries Press the AVR Settings Button Make certain front-panel sensor is in line of sight of remote or connect an optional remote sensor
Intermittent buzzing in tuner	<ul style="list-style-type: none"> Local interference 	<ul style="list-style-type: none"> Move unit or antenna away from computers, fluorescent lights, motors or other electrical appliances
Surround Back Speaker settings cannot be accessed, and test tone does not play through Surround Back Speakers	<ul style="list-style-type: none"> Multizone system has been turned on, and the surround back channels were reassigned to multizone operation 	<ul style="list-style-type: none"> Use the menu system to access the Zone 2 menu and reassign the surround back channels to the main room
The XM Preview Channel (001) is silent	<ul style="list-style-type: none"> XM antenna is not plugged in XM antenna is not located in such a way as to enable reception XM signal requires a refresh 	<ul style="list-style-type: none"> Use an XM antenna module designed for use with XM Ready home audio equipment, and plug the module into the XM Radio Jack The XM antenna module needs an unobstructed view of the southern sky, or to be within range of an XM terrestrial repeater; if necessary, purchase an extension cable from your XM Radio dealer Visit www.xmradio.com
Unable to activate Program mode on remote	<ul style="list-style-type: none"> AVR Settings Button not held for at least 3 seconds 	<ul style="list-style-type: none"> Follow the instructions in the remote's LCD Display
Remote buttons light, but AVR does not respond	<ul style="list-style-type: none"> Remote is in Zone 2 mode 	<ul style="list-style-type: none"> Slide the Zone Switch at the bottom of the remote to the Zone 1 position
Unable to play Internet Radio	<ul style="list-style-type: none"> AVR is not able to access the Internet 	<ul style="list-style-type: none"> Make sure the Network Jack is connected to an active router; navigate to the Network Settings submenu in the System Setup menu and change the Network Settings line to "Manual"; contact your ISP to obtain the correct information for the other settings in this submenu
Unable to access content on PC from Network source	<ul style="list-style-type: none"> Content not in proper format Content has not been shared by network device 	<ul style="list-style-type: none"> Only content in the form of MP3, WMA and JPEG files may be shared with the AVR Network device must be running compatible software; network device must be programmed to share the content over the network; refer to the Network Playback section on page 37 for details

Additional information on troubleshooting possible problems with your AVR 7550HD, or installation-related issues, may be found in the list of "Frequently Asked Questions", which is located in the Product Support section at www.harmankardon.com.

REMOTE CONTROL RESET

To reset the remote to its factory defaults, erasing all product codes, learned codes, activities and other user programming:

1. Press and hold the AVR Settings Button for 3 seconds. The remote will enter Program mode, and its Main Menu will be displayed.
2. Use the ▲ / ▼ Buttons to scroll to the Remote Reset option, and press the OK Button. The process may take a few minutes, depending on the amount of user programming requiring erasure. Please wait until the “Remote Reset Complete” message appears before pressing any keys.

PROCESSOR RESET

If the unit behaves erratically after a power surge, first turn off the Main Power Switch and unplug the AC power cord for at least 3 minutes. Plug the cord back in and turn the receiver on. If this doesn't help, reset the AVR.

To reset the AVR 7550HD, place it in Standby mode (press the front panel Standby/On Switch so that the Power Indicator turns amber).

Then press the front-panel AVR Settings and Source List Buttons simultaneously until the RESET message appears

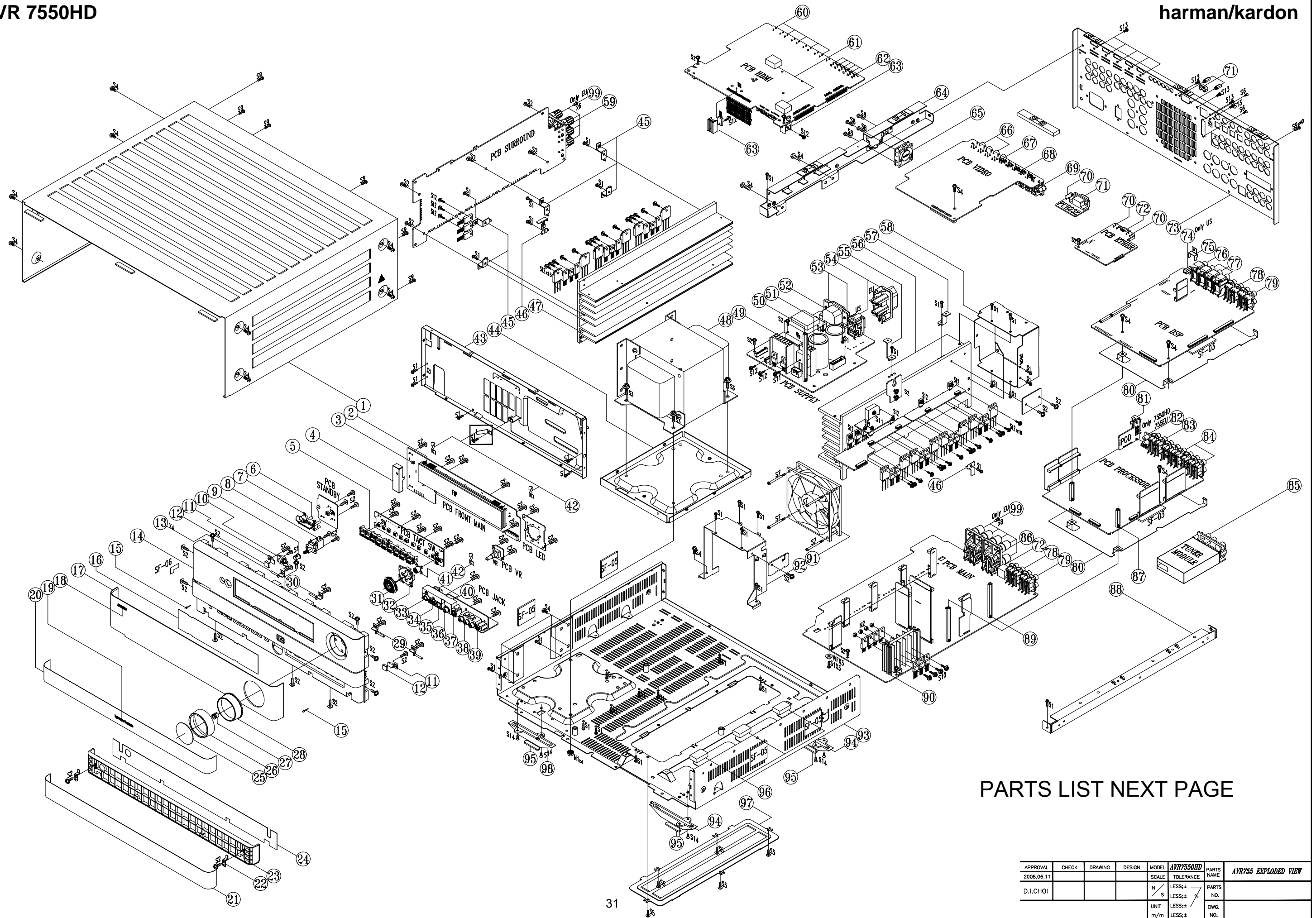

PARTS LIST NEXT PAGE

APPROVAL	CHECK	DRAWING	DESIGN	MODEL	SCALE	TOLERANCE	PARTS NAME
2008.06.11				AVR7550HD	N	LESS:±	AVR755 EXPLODED VIEW
D.I.CHOI					S	LESS:±	PARTS NO.
					UNIT	LESS:±	DWG. NO.
					m/m	LESS:±	

AVR7550HD Exploded View Part list					
NO	Designator if applicable	AVR7550HD US Part Number	AVR755 EU Part Number	Description	QTY
1		CKC1A184S60		COVER TOP	1
2		CMH1A285		HOLDER , VFD AVR7550HD	1
3		CHG1A394		RUBBER , SENSOR AVR7550HD	1
4		CMC1A335		SHIELD , IR AVR7550HD	1
5		CBT1A1066H61		BUTTON , 9KEY AVR7550HD	1
6		CBT1A1070B24		BUTTON , STANDBY AVR7550HD	1
7		CGL1A270		INDICATOR , STANDBY	1
8	SW3550	CSH1A001ZV		SWITCH	1
9		CBC1A162H61Z		BUTTON , POWER AVR7550HD	1
10		CDG1A026		GEAR , DAMPER(DP120)	1
11		CMH1A284		HOLDER , MAGNET AVR7550HD	2
12		CJC1A009		MAGNET , AVR7550HD(10X10X4t)	2
13		CDF1A020		SHAFT , DOOR AVR7550HD	4
14		CGW1A448R4ZB24	CGW1A448R4YB24	BODY , FRONT AVR7550HD	1
15		CHG1A385		RUBBER , DOOR AVR7550HD	2
16		CMZ1A129Z		FILTER , VFD AVR7550HD	1
17		CGU1A416A25Z		WINDOW , FIP AVR7550HD	1
18		CGB1A210Z	CGB1A196Z	BADGE Model Name	1
19		CGB1A158Y		BADGE , FRONT HARMAN/KARDON	1
20		CGX1A405C66Z		VENNER , AL FRONT AVR7550HD	1
21		CGX1A404C66Z		VENNER , AL DOOR AVR7550HD	1
22		CMD1A646		BRACKET , MAGNET AVR7550HD	2
23		CGR1A488B24		DOOR , UNDER	1
24		CGX1A403Z		PLATE , DOOR AVR7550HD	1
25		CGU1A318		ORNAMENT , VOLUME AVR255	1
26		CGK1A131C63		KNOB , COVER AVR7550HD	1
27		CMH1A214		HOLDER , VOLUME	1
28		CGL1A222		INDICATOR , VOLUME	1
29		CMD1A647		BRACKET , SHAFT HINGE L AVR7550HD	2
30		CMD1A648		BRACKET , SHAFT HINGE R AVR7550HD	2
31		CBT1A1067H61Z		BUTTON , 4 DIRECTION AVR7550HD	1
32		CBT1A1069		RETAINER, OK BUTTON AVR7550HD	1
33	JA3503	HJJ2E021Z		JACK , HEADPHONE	1
34	JA3507	CJJ9X005Z		JACK , USB(ANGLE, AU PLATE, YKF45-0041N)	1
35	JA3504	HJSTORX177L		MODULE , OPTICAL(RX)	1
36	JA3505	CJJ4M061Z		JACK , RCA (1P, 107BAG, OR, AU PL)	1
37	JA3502	CJJ9M006Z		JACK , DIN (1P, S-VHS, 434A, AU PL)	1
38	JA3501	CJJ4S046Z		JACK , RCA (3P, 303, YL WH RD, AU)	1
39	JA3506	HJJ2E017Z		JACK	1
40		CMC1A332		SHIELD , DIGITAL AVR7550HD	1
41		CBT1A1068H61Z		BUTTON , OK AVR7550HD	1
42		CMC1A334		PLATE , SPRING GND(0.2T) AVR7550HD	3
43		CMD1A649		CHASSIS , FRONT AVR7550HD	1
44		CMD1A650		BRACKET , TRANS BOTTOM AVR7550HD	1
45		CMD1A660		BRACKET , HEAT SINK AVR7550HD	5
46		CMD1A657		BRACKET , POSISTOR AVR7550HD	2
47		CMY1A292		HEAT SINK , SURR AMP AVR7550HD	1
48		CLT5W031ZU		TRANS , MAIN POWER AVR7550HD (UL, 120V 60Hz)	1
49		CMY3A239		HEAT SINK	1
50		CDF1A022		STAND OFF(HEX M4x87.4H) AVR7550HD	1
51		CMY2A294		HEAT SINK , DIODE AVR7550HD	1
52	JA3000	CJJ8A007ZD		JACK , AC INLET (2P, AC054S020A,10A, 250V)	1
53		CMD1A656		BRACKET , AC INLET AVR7550HD	2
54	JA3001	KJJ7A013Z		OUTLET , AC 1 PIN USA	1
55		CMD1A659		BRACKET , VIDEO AVR7550HD	1
56		CMY1A291		HEAT SINK , MAIN AVR7550HD	1
57		CMD1A645		BRACKET , ETHER AVR7550HD	1
58		CMD1A653		BRACKET , FAN REAR AVR7550HD	1
59	JA901	CJJ5R014Z		TERMINAL , SPEAKER (6P, GN/BN/TA, SCREW , AU)	1
60	JA2006	CJJ9H004Z		JACK , HDMI GOLD	1
60	JA2007	CJJ9H004Z		JACK , HDMI GOLD	1
60	JA2008	CJJ9H004Z		JACK , HDMI GOLD	1
60	JA2009	CJJ9H004Z		JACK , HDMI GOLD	1
60	JA2010	CJJ9H004Z		JACK , HDMI GOLD	1
61		CHG1A407		RUBBER 20X15X9t	2
62	JA2000	CJJ2D008Z		JACK , STEREO	1
62	JA2001	CJJ2D008Z		JACK , STEREO	1
62	JA2002	CJJ2D008Z		JACK , STEREO	1
62	JA2003	CJJ2D008Z		JACK , STEREO	1

NO	Designator if applicable	AVR7550HD US Part Number	AVR755 EU Part Number	Description	QTY
62	JA2004	CJJ2D008Z		JACK , STEREO	1
62	JA2005	CJJ2D008Z		JACK , STEREO	1
63		CMY2A223		HEAT SINK	1
63		CMY2A223		HEAT SINK	1
64		CMD1A658		BRACKET , FRAME GUIDE AVR7550HD	1
65		CFNCF12310XS		MOTOR , FAN (30 X 30 X 20mm 12V 5000RPM 300mm)	1
66	JA1503	CJJ4R036Y		JACK , RCA (6P, 610A, RD BL GN x 2, AU PL)	1
66	JA1504	CJJ4R036Y		JACK , RCA (6P, 610A, RD BL GN x 2, AU PL)	1
67	JA1500	CJJ9R002Z		JACK , RCA/DIN (3P, 304A, YLx3, S-VHSx3, AU PL)	1
68	JA1501	CJJ9P004Z		JACK , RCA/DIN (2P, 220A, YLx2, S-VHSx2, AU PL)	1
69	JA1502	CJJ4M063Z		JACK , RCA/DIN (1P, R102D04, YL, AU PL)	1
70	HK5000	CMC1A337		BRACKET , GND SMALL AVR7550HD	1
70	HK5001	CMC1A337		BRACKET , GND SMALL AVR7550HD	1
71	JA3251	CJJ9W001Z		JACK , 9P D-SUB FEMALE(RS-232C, SEMCO)	1
72	JA103	CJJ9L004Z		JACK , RJ-45	1
72	JA5000	CJJ9L004Z		JACK , RJ-45	1
73		CKF1A381Z	CKF2A381Y	PANEL , REAR	1
74	JA4000	CJJ9L006Z	X	JACK , XM	1
75		CMD1A661		BRACKET , XM AVBR7550HD	1
76	JA4001	CJS9U011Z		JACK , OPTICAL+COXIAL(GOLD PLATE)	1
77	JA4002	CJS9U016Z		JACK , OPT + 1P RCA (RX 5V YKC22-0873V AU PLATE)	1
77	JA4003	CJS9U016Z		JACK , OPT + 1P RCA (RX 5V YKC22-0873V AU PLATE)	1
77	JA4004	CJS9U016Z		JACK , OPT + 1P RCA (RX 5V YKC22-0873V AU PLATE)	1
78	JA4005	CJJ4P063Z		JACK , RCA (4P, 401DAG, GN BN PP TA, AU PL)	1
78	JA102	CJJ4P063Z		JACK , RCA (4P, 401DAG, GN BN PP TA, AU PL)	1
79	JA4006	CJJ4P055Z		JACK 4P WH/BL/RD/GY	1
79	JA101	CJJ4P055Z		JACK 4P WH/BL/RD/GY	1
80		CMC1A339		SHIELD , DIGITAL AVR7550HD	2
81	JA3201	CJJ9L010Z		JACK , IPOD CONNECTOR	1
82	JA1004	CJJ4M062Z	x	JACK , RCA (1P, 115AG, PP, AU PL)	1
83	JA1003	CJJ4P019Y		JACK , BOARD	1
84	JA1001	CJJ4R020Z		JACK , BOARD	1
84	JA1002	CJJ4R020Z		JACK , BOARD	1
85		CNVMB011MW0-81	CNVMB114MW1-81	TUNER MODULE	1
86	JA104	CJJ5Q017Z		TERMINAL , SPEAKER (8P, GY/BL/RD/WH, SCREW , AU)	1
87		CDF1A023		STAND OFF(HEX M4X0.7 6X31.9H) AVR7550HD	2
88		CMD1A651		BRACKET , FRAME GUIDE AVR7550HD	1
89		CDF1A021		STAND OFF(HEX M4X61.5H) AVR7550HD	3
90		CMY1A295		HEAT SINK , REG. TR AVR7550HD	1
91		CFNCF12925HS		MOTOR , FAN (92 X 92 X 25mm 12V 3500RPM 300mm)	1
92		CMD1A652		BRACKET , FAN FRONT AVR7550HD	1
93		CUA1A283		CHASSIS , MAIN AVR7550HD	1
94		CKL1A100		FOOT , R AVR7550HD	3
95		CHG1A373		CUSHION , FOOT	4
96		CHG1A387		SPONGE(30X30X10T) AVR7550HD	3
97		CMD1A654		COVER , BOTTOM AVR7550HD	1
98		CKL1A101		FOOT , L AVR7550HD	1
99			CRE1A078	Locker	14
FIP	DP3501	CFL18BT19GINK		F.I.P , AVR7550HD(18-BT-19GINK)	1
SW	S2000	HST1A020ZT		SW , TACT	1
SW	S3501~15	HST1A020ZT		SW , TACT	15
SW	S3515	HST1A020ZT		SW , TACT	1
VR	VR3501	CSR2A046Z		ENCODER , SW EC12E242803	1
N1		CNE1A011		NUT , M4 HEXAGON CIRCULAR EX AVR7550HD	4
N2		CNE1A012		NUT , M3	3
SF-01		CMC1A358		Shield Foam 10x50x1t	5
SF-02		CMC1A357		Shield Foam 5x50x3t	1
SF-03		CHG1A444		CUSHION DSP	2
SF-04		CHS1A032		HEMELON TAPE	3
SF-05		CHG1A445		CUSHION BOTTOM	4
SF-06		CPE1A010		Oil Paper	1

SERVICE PROCEDURE

ALIGNMENT PROCEDURES

1.MAIN AMP idling Adjustment

SET CONDITION

- 1) SEMI VOLUME POSITION at MAIN/SURROUND AMP Board
 MAIN:VR101,VR102,VR103,VR104
 SURROUND:VR501,VR601,VR701

 NO Signal/No Load
 AC Line Voltage:120V/60Hz.230V/50Hz
- 2) After turning on the unit keep it over than 25min (keep the power/Driver TR as normal temperature)
- 3) Adjust the voltage value of primary&secondary of wafer to be 25mV by rotating the semi volume of each channel to the right

CHANNEL	ADJUSTMENT	MEASUREMENT	VOLTAGE
FRONT-L CH	VR104	P114	23+/-2mV
FRONT-R CH	VR101	P111	23+/-2mV
SURROUND-L CH	VR103	P113	23+/-2mV
SURROUND-R CH	VR102	P112	23+/-2mV

- 4) CAUTION
 In case that power TR or DRIVER TR is needed to be replace for repairing the corresponding channel should be adjusted again

 FRONT AMP:Q437.Q333.Q335.Q439.Q438.Q334.Q336.Q440
 SURROUND AMP:Q618.Q619.Q518.Q519.Q718.Q719

2.SURROUND BACK AMP idling Adjustment

SET CONDITION

- 1) SEMI VOLUME POSITION at CENTER/SURROUND BACK AMP Board
 CENTER:VR501
 SURROUND BACK:VR601.VR701

 NO Signal/No Load
 AC Line Voltage:120V/60Hz.230V/50Hz
- 2) After turning on the unit keep it over than 25min (keep the power/Driver TR as normal temperature)
- 3) Adjust the voltage value of primary&secondary of wafer to be 25mV by rotating the semi volume of each channel to the right

CHANNEL	ADJUSTMENT	MEASUREMENT	VOLTAGE
CENTER	VR501	P501	23+/-2mV
SURR BACK-L CH	VR601	P601	23+/-2mV
SURR BACK-R CH	VR701	P701	23+/-2mV

- 4) CAUTION
 In case that power TR or DVIER TR is needed to be replace for repairing the corresponding channel should be adjusted again

 CENTER AMP:Q519,Q517.Q516,Q518
 SUR BACK AMP:Q618.Q617.Q618.Q619.Q716.Q717.Q718.Q719

3.Cautions for main adjustment

- 1) At MAIN/SUPPLY BOARD.use the below capacitor after discharging for sufficient time for preventing possible damage from electrical spark

MAIN BOARD	C151.C152	AVR7550HD 15000/63V
SUPPLY BOARD	C3101,C3102	AVR7550HD 10000/63V

- 2)The checking for MAIN/SUPPLY BOARD should have the discharging circuit discharge over 30sec.through(4R70hm 10W)resistor after push power sw off

Alignment and test position (MAIN AMP BOARD)

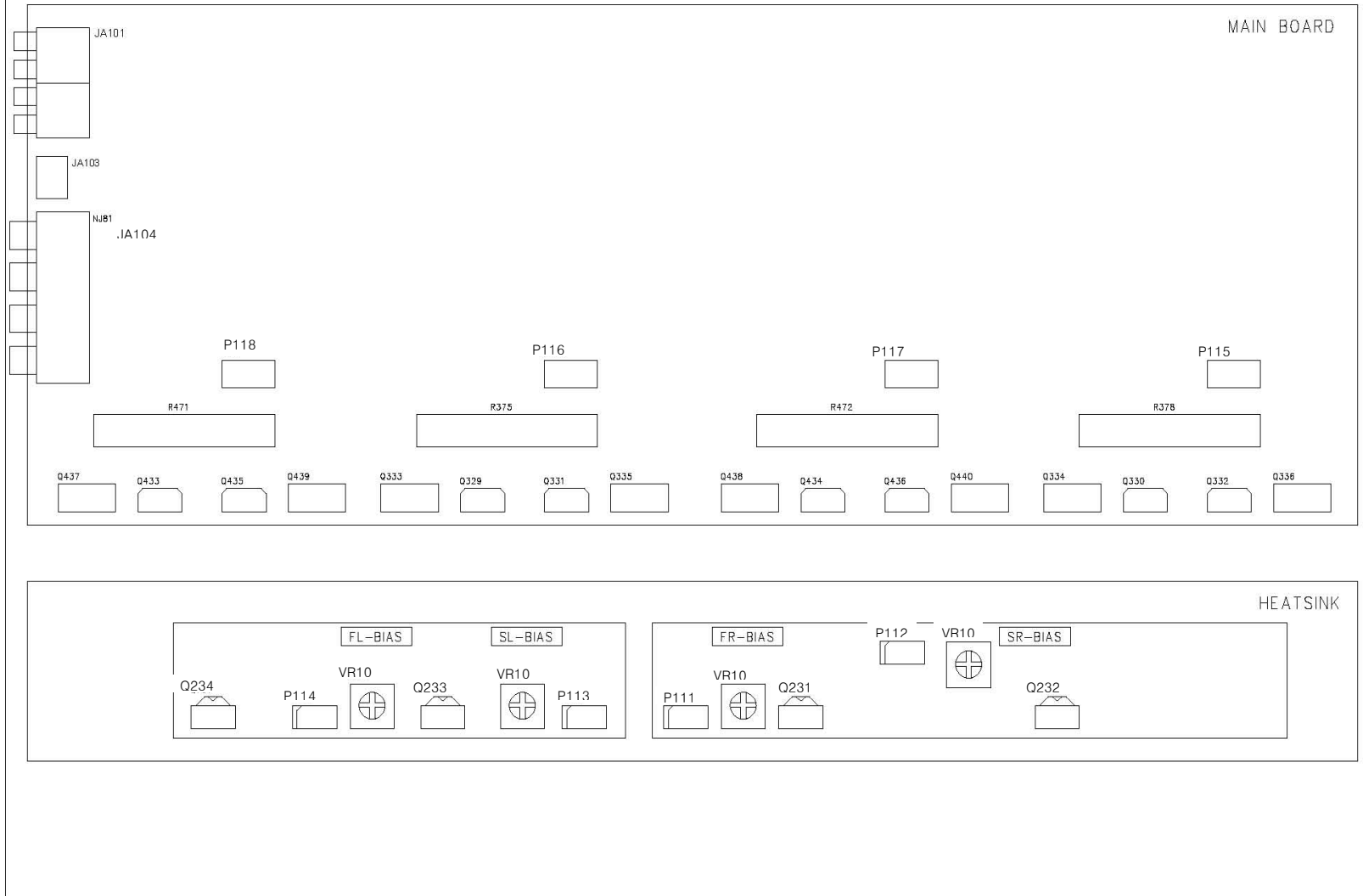

Alignment and test position (SURROUND BOARD)

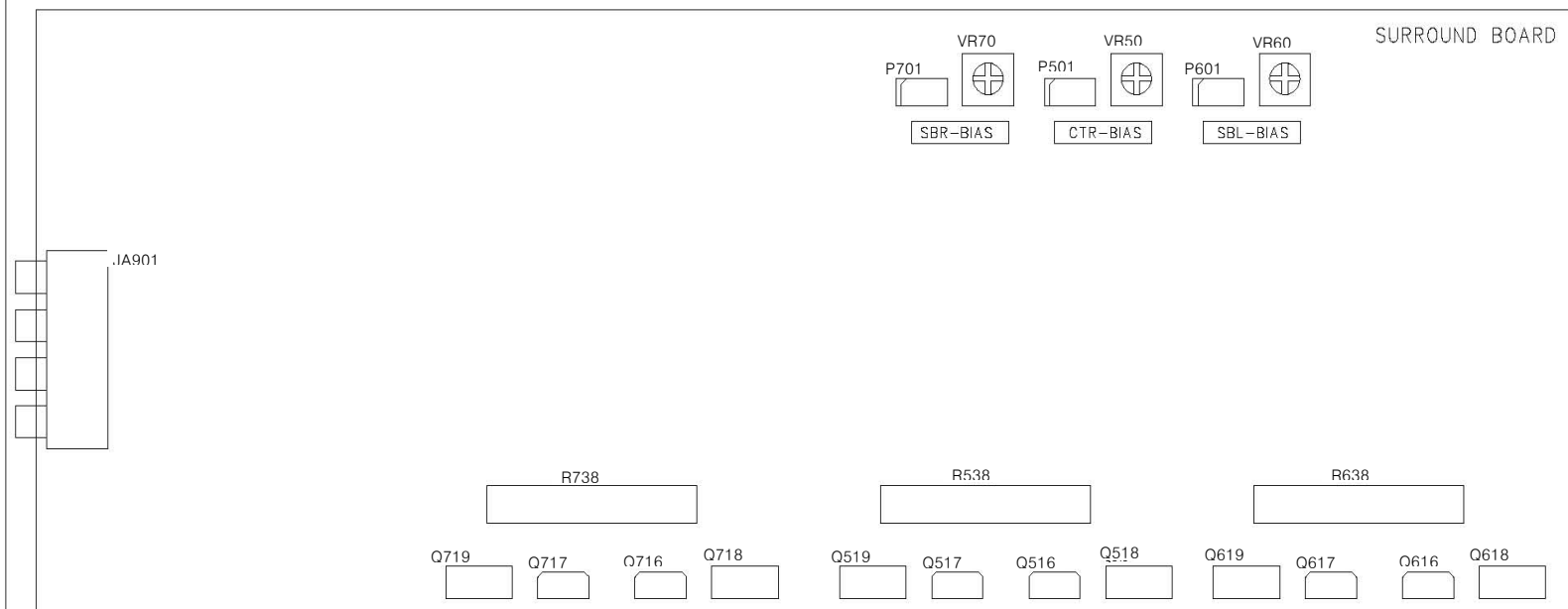

Revision List – Rev 1.4
 - Change COAX4 IN/OUT to COAX4 INPUT
 - Add HDMI SPDIF input from VIDEO

Revision List – Rev 1.6 – 2007/12/03
 - Add DM850 USB Input

Revision List – Rev 1.7 – 2008/05/21
 - Add VOL gain on AUDIO line

Revision List – Rev 1.8 – 2008/08/25
 - Add digital audio signal configuration
 - Delete Zone2 ADC

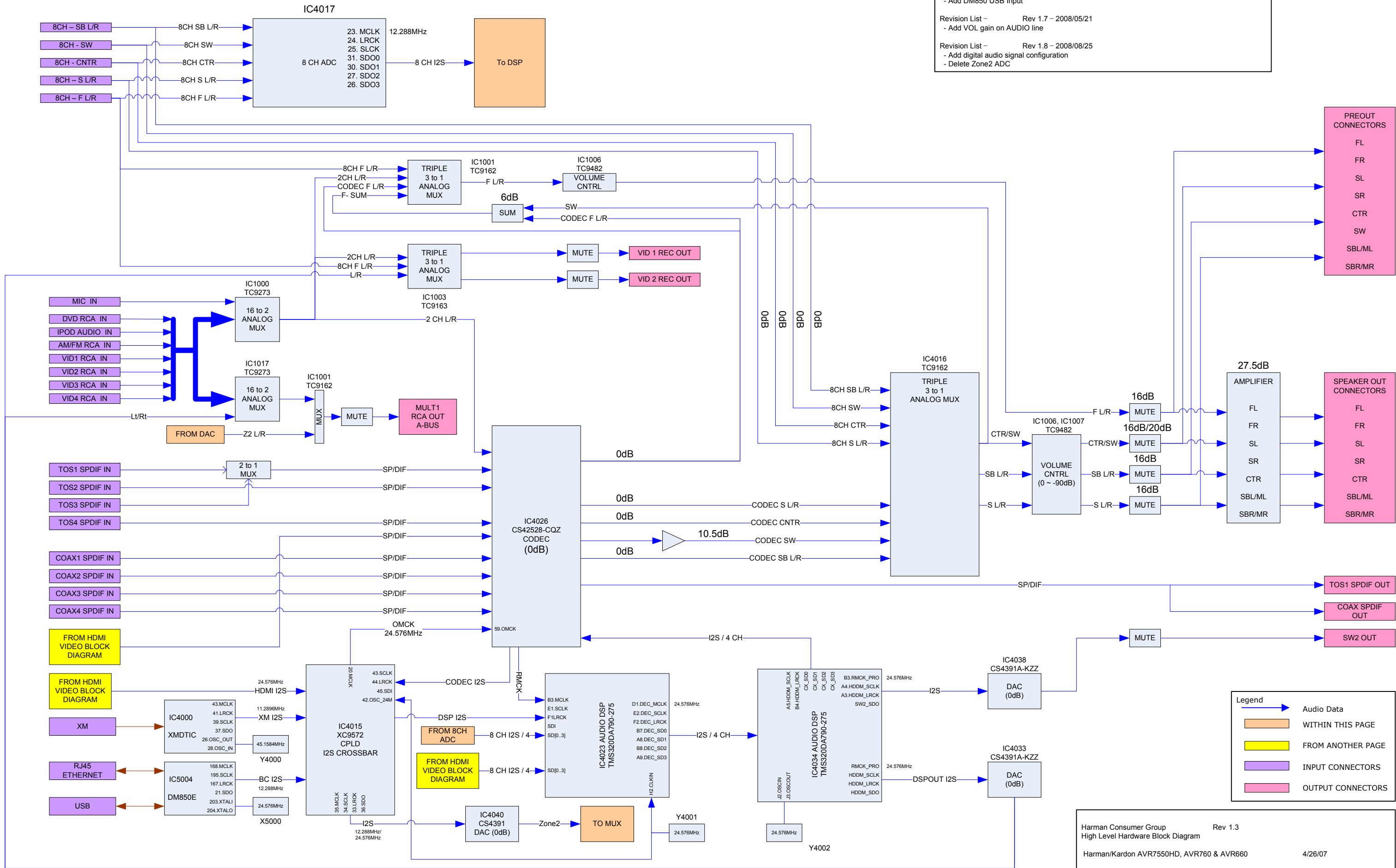

Legend

- Audio Data
- WITHIN THIS PAGE
- FROM ANOTHER PAGE
- INPUT CONNECTORS
- OUTPUT CONNECTORS

Harman Consumer Group Rev 1.3
 High Level Hardware Block Diagram
 Harman/Kardon AVR7550HD, AVR760 & AVR660 4/26/07

Revision List - Rev 1.4
 - Change ADV7320 to ADV7340
 - Delete component analog bypass
 - Add clock doubler for 480i
 - Add SPDIF to DSP & HDMI Transceiver

Revision List - Rev 1.5
 - Change ADV7320 to ADV7340

Revision List - Rev 1.6 - 2007/12/03
 - Delete Bypass Video output.
 - Add DM850 USB Input

Revision List - Rev 1.8 - 2008/08/25
 - Add IC reference No.

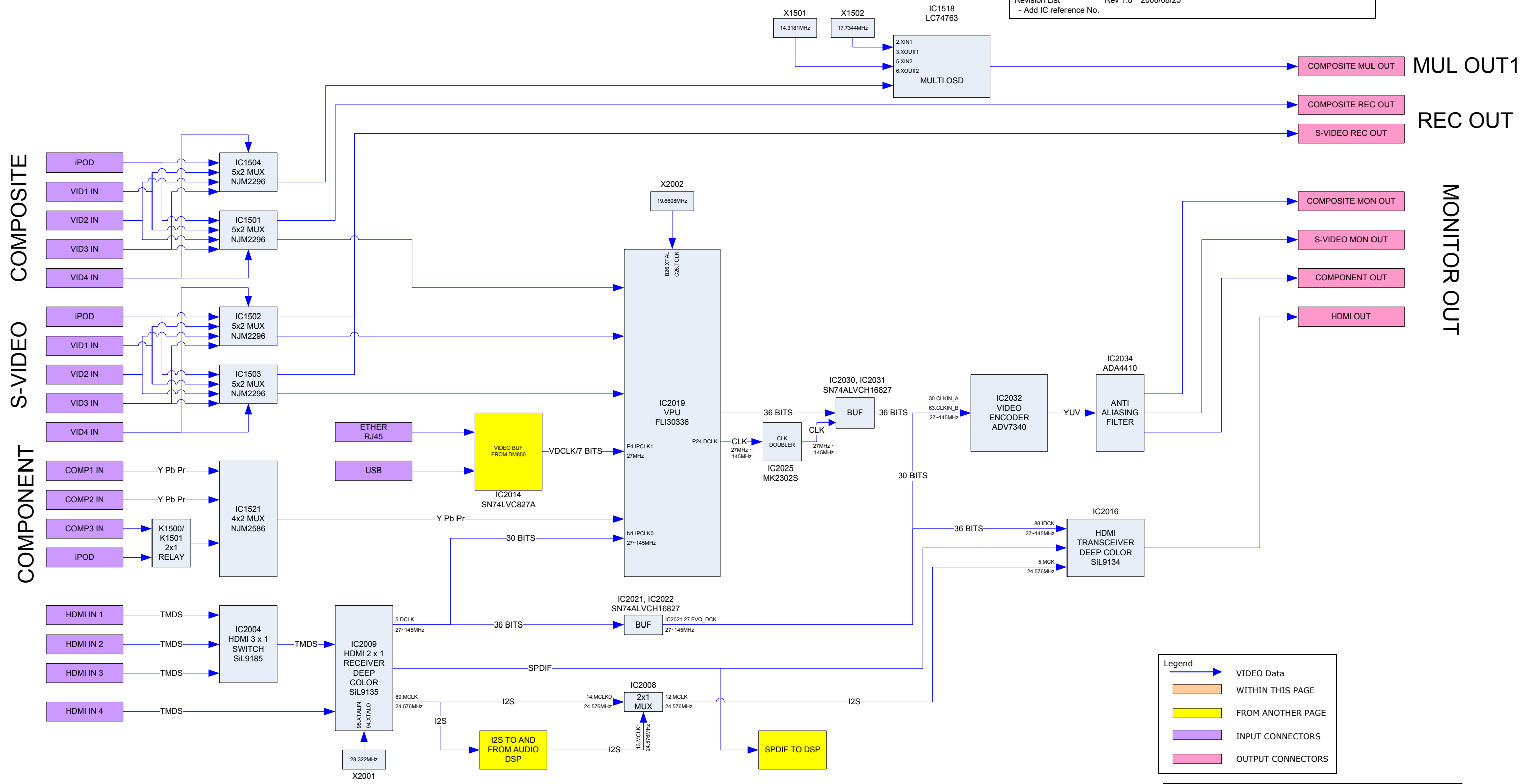

Legend

- Blue arrow: VIDEO Data
- Orange box: WITHIN THIS PAGE
- Yellow box: FROM ANOTHER PAGE
- Purple box: INPUT CONNECTORS
- Pink box: OUTPUT CONNECTORS

Harman Consumer Group Rev 1.3
 High Level Hardware Block Diagram
 Harman/Kardon AVR7550HD, AVR760 & AVR660 3/23/07

Revision List - Rev 1.6 - 2007/12/03
 - Change VIDEO ENCODER I2C.
 Revision List - Rev 1.8 - 2008/08/25
 - Add IC reference No.

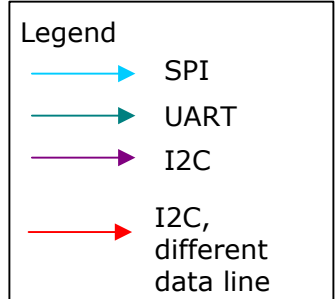
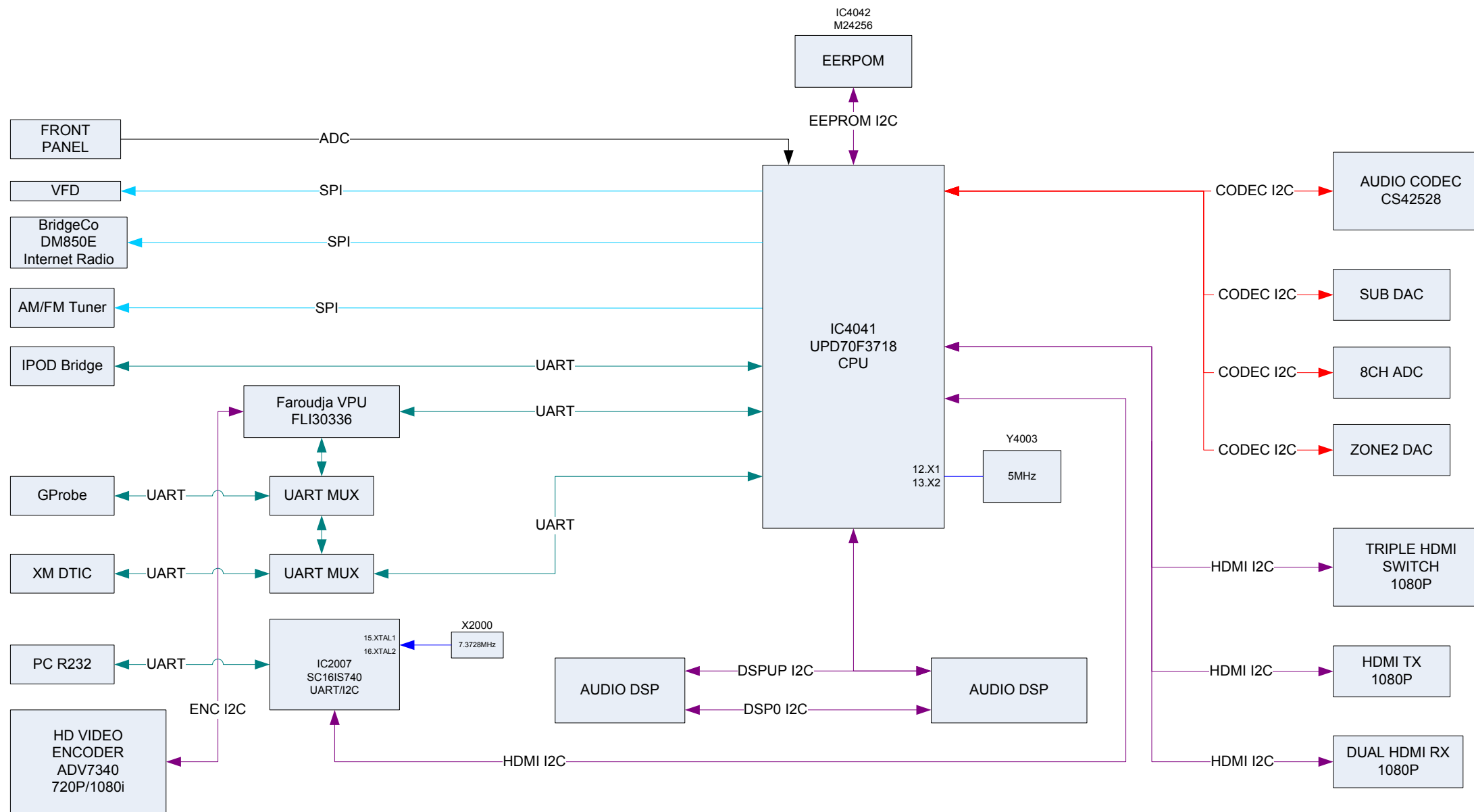

Harman International Industries Inc., Proprietary and Confidential

Harman Consumer Group
 High Level Hardware Block Diagram
 Harman/Kardon AVR7550HD, AVR760 & AVR660
 Rev 1.6
 4/26/07

AVR7550HD Electrical Parts List			
Ref. Designator	Part Number	Description	Qty
FRONT PCB ASSY		COP12040B	
<i>Capacitors</i>			
C3501	CCUC1H101JA	CAP , CHIP	100pF 50V CH J NPO 0805
C3502	CCUC1H100JA	CAP , CHIP (10PF/50V D CH 2012)	10pF 50V CH D N 0805
C3503	CCUC1H122KC	CAP , CHIP (1200PF/50V SL J X7R 2012)	1n2F 50V SL J X7R 0805
C3504	CCUC1H100JA	CAP , CHIP (10PF/50V D CH 2012)	10pF 50V CH D N 0805
C3505	CCUC1H122KC	CAP , CHIP (1200PF/50V SL J X7R 2012)	1n2F 50V SL J X7R 0805
C3507	CCUS1H104KC	CAP , CHIP	0.1UF 50V K
C3508	CCUC1H100JA	CAP , CHIP (10PF/50V D CH 2012)	10pF 50V CH D N 0805
C3513	CCUS1H101JA	CAP , CHIP	100PF 50V J
C3514	CCUS1H104KC	CAP , CHIP	0.1UF 50V K
C3515	CCUS1H104KC	CAP , CHIP	0.1UF 50V K
C3517	CCUS1H104KC	CAP , CHIP	0.1UF 50V K
C3518	CCUS1H101JA	CAP , CHIP	100PF 50V J
C3519	CCUS1H101JA	CAP , CHIP	100PF 50V J
C3520	CCUS1H101JA	CAP , CHIP	100PF 50V J
C3521	CCUS1H101JA	CAP , CHIP	100PF 50V J
C3523	CCUS1H104KC	CAP , CHIP	0.1UF 50V K
C3524	CCUC1H821JA	CAP , CHIP (820PF/50V SL J NPO 2012)	820pF 50V SL J NPO 0805
C3525	CCUC1H821JA	CAP , CHIP (820PF/50V SL J NPO 2012)	820pF 50V SL J NPO 0805
C3526	CCUS1H223KC	CAP , CHIP	0.022UF 50V K
C3537	CCUS1H223KC	CAP , CHIP	0.022UF 50V K
C3538	CCUS1H101JA	CAP , CHIP	100PF 50V J
C3539	CCUS1H101JA	CAP , CHIP	100PF 50V J
C3540	CCUS1H104KC	CAP , CHIP	0.1UF 50V K
C3541	CCUS1H101JA	CAP , CHIP	100PF 50V J
C3542	CCUS1H101JA	CAP , CHIP	100PF 50V J
C3550	CCUS1H221JA	CAP , CHIP	220PF 50V J
C3551	CCUS1H101JA	CAP , CHIP	100PF 50V J
C3552	CCUS1H101JA	CAP , CHIP	100PF 50V J
C3554	CCUS1H104KC	CAP , CHIP	0.1UF 50V K
C3557	CCUC2A103KC	CAP , CHIP(2012 SIZE)	0.01UF 50V K
C3558	CCUS1H220JA	CAP , CHIP	22PF 50V J
C3559	CCUS1H104KC	CAP , CHIP	0.1UF 50V K
C3560	CCUS1H222KC	CAP , CHIP	2200PF 50V K
C3561	CCUS1H222KC	CAP , CHIP	2200PF 50V K
C3562	CCUS1H104KC	CAP , CHIP	0.1UF 50V K
C3565	CCUS1H104KC	CAP , CHIP	0.1UF 50V K
C3506	CCEA1CK5470T25	CAP , ELECT (47uF/16V M 6.3X5mm P2.5mm)	47uF 16V +20% D5x7 P2.5MM 85C
C3509	CCME2A473JXT	CAP , METALLIZED FILM	47NF 100V 20% CPM
C3510	CCBS1H104ZFT	CAP , CERAMIC	0.1UF 50V Z
C3511	CCBS1H104ZFT	CAP , CERAMIC	0.1UF 50V Z
C3512	CCEA1CK5470T25	CAP , ELECT (47uF/16V M 6.3X5mm P2.5mm)	47uF 16V +20% D5x7 P2.5MM 85C
C3516	CCEA1CH101T	CAP , ELECT	100UF 16V
C3522	CCME2A473JXT	CAP , METALLIZED FILM	47NF 100V 20% CPM
C3544	CCEA1AH221T	CAP , ELECT	220uF 10V +20% D6.3xL11 P5MM 85C
C3545	CCEA1CK5470T25	CAP , ELECT (47uF/16V M 6.3X5mm P2.5mm)	47uF 16V +20% D5x7 P2.5MM 85C
C3546	CCEA1CK5470T25	CAP , ELECT (47uF/16V M 6.3X5mm P2.5mm)	47uF 16V +20% D5x7 P2.5MM 85C
C3547	CCEA1CK5100T25	CAP , ELECT (10UF/16V M 4X5mm P2.5mm)	10UF +20% 16V D4XL7 P2.5MM
C3549	CCEA1CK5100T25	CAP , ELECT (10UF/16V M 4X5mm P2.5mm)	10UF +20% 16V D4XL7 P2.5MM
C3556	CCEA1CK5470T25	CAP , ELECT (47uF/16V M 6.3X5mm P2.5mm)	47uF 16V +20% D5x7 P2.5MM 85C
C3566	CCEA1CK5470T25	CAP , ELECT (47uF/16V M 6.3X5mm P2.5mm)	47uF 16V +20% D5x7 P2.5MM 85C
C3567	CCEA1AH221T	CAP , ELECT	220UF 10V
<i>Semiconductors</i>			
D3501	HVD1SS355T	DIODE , CHIP	1SS355TE-17
D3502	HVD1SS355T	DIODE , CHIP	1SS355TE-17
D3511	HVD1SS355T	DIODE , CHIP	1SS355TE-17
D3512	HVD1SS355T	DIODE , CHIP	1SS355TE-17
D3513	CVDPG05GBUSCRTP	DIODE , ESD PROTECTION USC	PG05GBUSC-RTK/P , KEC
D3514	CVDPG05GBUSCRTP	DIODE , ESD PROTECTION USC	PG05GBUSC-RTK/P , KEC
D3515	HVDUDZ5.1BSR	DIODE , ZENER (CHIP,5.1V)	UDZ5 5.1B 5.1V 200mW UMD2
D3518	HVD1SS355T	DIODE , CHIP	1SS355TE-17
D3519	HVD1SS355T	DIODE , CHIP	1SS355TE-17
IC3501	HVINJM2068MDTE1	I.C , DUAL OP AMP	NJM2068MD-TE1
IC3502	HVI74HCU04AFNG	I.C , INVERTER	TC74HCU04AFNG(TOSHIBA)
Q3501	HVTKTC3875SYRTK	TRANSISTOR , CHIP NPN	KTC3875S Y RTK
Q3502	HVTKTC3875SYRTK	TRANSISTOR , CHIP NPN	KTC3875S Y RTK

Ref. Designator	Part Number	Description		Qty
FRONT PCB ASSY		COP12040B		
Q3503	HVTKTA1504SYRTK	TRANSISTOR , CHIP PNP	KTA1504S Y RTK	1
Q3504	HVTKRA107S	TRANSISTOR , CHIP PNP	KRA107S SOT-23	1
Q3505	HVTKRC107S	TRANSISTOR , CHIP PNP	KRC107S SOT-23	1
Q3507	HVTKRC107S	TRANSISTOR , CHIP PNP	KRC107S SOT-23	1
Q3508	HVTKRC107S	TRANSISTOR , CHIP PNP	KRC107S SOT-23	1
Q3509	HVTKRC107S	TRANSISTOR , CHIP PNP	KRC107S SOT-23	1
D3503	HVD1N4007T	DIODE	1N4007 1000V 1A DO-41	1
D3504	HVD1N4148T	DIODE	1N4148	1
Q3506	CVTMPA06ATPF	TRANSISTOR , DRIVER(NPN,120V, 500mA TO-92)	MPSA06-AT/PF , KEC	1
D3505	CVD1L0345W31BOCT20	L.E.D , WHITE	CVD1L0345W31BOCT201	1
D3506	CVD1L0345W31BOCT20	L.E.D , WHITE	CVD1L0345W31BOCT201	1
D3507	CVD1L0345W31BOCT20	L.E.D , WHITE	CVD1L0345W31BOCT201	1
D3508	CVD1L0345W31BOCT20	L.E.D , WHITE	CVD1L0345W31BOCT201	1
D3509	CVD1L0345W31BOCT20	L.E.D , WHITE	CVD1L0345W31BOCT201	1
D3510	CVD1L034FA22M0MA	L.E.D , AMBER DIFFUSED	1L034FA22M0MA001	1
RM3502	CRVLP-200TL	DIODE , PIN PHOTO DIODE LP-200TL	LP-200TL	1
<i>Resistors</i>				
R3500	CRJ10DJ103T	RES , CHIP	10K ohm 1/16W 5% 0603	1
R3501	CRJ10DJ683T	RES , CHIP	68K ohm 1/16W 5% 0603	1
R3502	CRJ10DJ564T	RES , CHIP	560K ohm 1/10W 5% 0805	1
R3503	CRJ10DJ103T	RES , CHIP	10K ohm 1/16W 5% 0603	1
R3504	CRJ10DJ272T	RES , CHIP	2K7 ohm 1/16W 5% 0603	1
R3505	CRJ10DJ105T	RES , CHIP	1M ohm 1/16W 5% 0603	1
R3506	CRJ10DJ103T	RES , CHIP	10K ohm 1/16W 5% 0603	1
R3507	CRJ10DJ105T	RES , CHIP	1M ohm 1/16W 5% 0603	1
R3511	CRJ10DJ101T	RES , CHIP	100 ohm 1/16W 5% 0603	1
R3516	CRJ10DJ683T	RES , CHIP	68K ohm 1/16W 5% 0603	1
R3517	CRJ10DJ683T	RES , CHIP	68K ohm 1/16W 5% 0603	1
R3518	CRJ10DJ103T	RES , CHIP	10K ohm 1/16W 5% 0603	1
R3519	CRJ10DJ563T	RES , CHIP	56K ohm 1/16W 5% 0603	1
R3522	CRJ10DJ222T	RES , CHIP	2K2 ohm 1/16W 5% 0603	1
R3525	CRJ10DJ102T	RES , CHIP	1K ohm 1/16W 5% 0603	1
R3526	CRJ10DJ122T	RES , CHIP	1K2 ohm 1/16W 5% 0603	1
R3527	CRJ10DJ152T	RES , CHIP	1K5 ohm 1/16W 5% 0603	1
R3528	CRJ10DJ222T	RES , CHIP	2K2 ohm 1/16W 5% 0603	1
R3529	CRJ10DJ272T	RES , CHIP	2K7 ohm 1/16W 5% 0603	1
R3530	CRJ10DJ332T	RES , CHIP	3K3 ohm 1/16W 5% 0603	1
R3531	CRJ10DJ102T	RES , CHIP	1K ohm 1/16W 5% 0603	1
R3532	CRJ10DJ122T	RES , CHIP	1K2 ohm 1/16W 5% 0603	1
R3533	CRJ10DJ152T	RES , CHIP	1K5 ohm 1/16W 5% 0603	1
R3534	CRJ10DJ222T	RES , CHIP	2K2 ohm 1/16W 5% 0603	1
R3535	CRJ10DJ272T	RES , CHIP	2K7 ohm 1/16W 5% 0603	1
R3536	CRJ10DJ332T	RES , CHIP	3K3 ohm 1/16W 5% 0603	1
R3537	CRJ10DJ562T	RES , CHIP	5K6 ohm 1/16W 5% 0603	1
R3538	CRJ10DJ753T	RES , CHIP	75K ohm 1/16W 5% 0603	1
R3539	CRJ10DJ753T	RES , CHIP	75K ohm 1/16W 5% 0603	1
R3542	CRJ10DJ102T	RES , CHIP	1K ohm 1/16W 5% 0603	1
R3544	CRJ10DJ222T	RES , CHIP	2K2 ohm 1/16W 5% 0603	1
R3546	CRJ10DJ222T	RES , CHIP	2K2 ohm 1/16W 5% 0603	1
R3547	CRJ10DJ473T	RES , CHIP	47K ohm 1/16W 5% 0603	1
R3548	CRJ10DJ0R0T	RES , CHIP	0 ohm 1/16W 0% 0603	1
R3550	CRJ10DJ472T	RES , CHIP	4K7ohm 1/16W 5% 0603	1
R3551	CRJ10DJ332T	RES , CHIP	3K3 ohm 1/16W 5% 0603	1
R3552	CRJ10DJ911T	RES , CHIP	910 ohm 1/16W 5% 0603	1
R3553	CRJ10DJ102T	RES , CHIP	1K ohm 1/16W 5% 0603	1
R3554	CRJ10DJ104T	RES , CHIP	100K ohm 1/16W 5% 0603	1
R3555	CRJ10DJ101T	RES , CHIP	100 ohm 1/16W 5% 0603	1
R3556	CRJ10DJ102T	RES , CHIP	1K ohm 1/16W 5% 0603	1
R3557	CRJ10DJ152T	RES , CHIP	1K5 ohm 1/16W 5% 0603	1
R3558	CRJ10DJ104T	RES , CHIP	100K ohm 1/16W 5% 0603	1
R3559	CRJ10DJ750T	RES , CHIP	75 ohm 1/16W 5% 0603	1
R3562	CRJ10DJ153T	RES , CHIP	15K ohm 1/16W 5% 0603	1
R3508	CRD20TJ100T	RES , CARBON	10 OHM 1/5W J	1
R3509	CRD20TJ473T	RES , CARBON	47K OHM 1/5W J	1
R3510	CRD20TJ100T	RES , CARBON	10 OHM 1/5W J	1
R3512	CRD20TJ471T	RES , CARBON	470 OHM 1/5W J	1
R3513	CRD20TJ471T	RES , CARBON	470 OHM 1/5W J	1
R3514	CRD20TJ101T	RES , CARBON	100 OHM 1/5W J	1
R3515	CRD20TJ101T	RES , CARBON	100 OHM 1/5W J	1

Ref. Designator	Part Number	Description		Qty
FRONT PCB ASSY		COP12040B		
R3520	CRD20TJ561T	RES , CARBON	560 OHM 1/5W J	1
R3521	CRD20TJ561T	RES , CARBON	560 OHM 1/5W J	1
R3523	CRD20TJ681T	RES , CARBON	680 OHM 1/5W J	1
R3524	CRD20TJ122T	RES , CARBON	1.2K OHM 1/5W J	1
R3540	CRD20TJ101T	RES , CARBON	100 OHM 1/5W J	1
R3541	CRD20TJ101T	RES , CARBON	100 OHM 1/5W J	1
R3543	CRD20TJ182T	RES , CARBON	1.8K OHM 1/5W J	1
R3545	CRD20TJ101T	RES , CARBON	100 OHM 1/5W J	1
R3560	CRD20TJ2R2T	RES , CARBON	2.2 OHM 1/5W J	1
R3561	CRD20TJ2R2T	RES , CARBON	2.2 OHM 1/5W J	1
<i>Miscellaneous</i>				
S3501	CST1A024ZT	SW , TACT		1
S3502	CST1A024ZT	SW , TACT		1
S3503	CST1A024ZT	SW , TACT		1
S3504	CST1A024ZT	SW , TACT		1
S3505	CST1A024ZT	SW , TACT		1
S3506	CST1A024ZT	SW , TACT		1
S3507	CST1A024ZT	SW , TACT		1
S3508	CST1A024ZT	SW , TACT		1
S3509	CST1A024ZT	SW , TACT		1
S3510	CST1A024ZT	SW , TACT		1
S3511	CST1A024ZT	SW , TACT		1
S3512	CST1A024ZT	SW , TACT		1
S3513	CST1A024ZT	SW , TACT		1
S3514	CST1A024ZT	SW , TACT		1
S3515	CST1A024ZT	SW , TACT		1
	CMC1A332	SHIELD , DIGITAL AVR755		1
	CMC1A335	SHIELD , IR AVR755		1
	CMH1A285	HOLDER , VFD AVR755		1
DP3501	CFL18BT19GINK	F.I.P , AVR755(18-BT-19GINK)	18BT019GINK	1
L3501	HLQ02C4R7KT	INDUCTOR 4.7UH	AL02TB4R7K 4.7uH 1.7ohm +10%	1
L3504	HLQ02C470KT	COIL , AXAIL	AL02TB470K 47uH 5.8ohm +10%	1
JA3501	CJJ4S046Z	JACK , RCA (3P, 303, YL WH RD, AU)	RCA-303G-06	1
JA3502	CJJ9M006Z	JACK , DIN (1P, S-VHS, 434A, AU PL)	DIN-434AG	1
JA3503	HJJ2E021Z	JACK , HEADPHONE	HTJ-035-13B	1
JA3504	HJSTORX177L	MODULE , OPTICAL(RX)	TORX177L	1
JA3505	CJJ4M061Z	JACK , RCA (1P, 107BAG, OR, AU PL)	RCA-107BAG-02 ORANGE	1
JA3506	HJJ2E017Z	JACK	HTJ064-05BG	1
JA3507	CJJ9X007Z	JACK , USB (GOLD)	317AE04XXA100X	1
N3501	CWB1B011400GN	11P WIRE ASS'Y(400MM, 2.0MM)	UL1007#26(TA) 400mm 2mm 11P RED	1
N3502	CWB1C004080GN	4P WIRE ASS'Y(80MM, 2.0MM)	UL1007#26(TA) 80mm 2mm 4P RED	1
N3503	CJP21GB116ZY	WAFER	GF120-21S-LS 1.25mm 21P	1
N3504	CWB1B007200GN	7P WIRE ASS'Y(200MM, 2.0MM)	UL1007#26(TA) 200mm 2mm 7P RED	1
N3505	CWB1C005150GN	5P WIRE ASS'Y(150MM, 2.0MM)	UL1007#26(TA) 150mm 2mm 5P RED	1
N3506	CWB1B003080GN	3P WIRE ASS'Y(80MM, 2.0MM)	UL1007#26(TA) 80mm 2mm 3P RED	1
N3507	CWBAVR755N3507	5P WIRE ASS'Y (550MM,2.0MM)	UL2547/1533#26(TA) 550mm 2mm 5P RED	1
N3509	CWBAVR755N3509	5P WIRE ASS'Y(700MM, 2.0MM)	UL1007/1533#24(TA) 700mm 2mm 5P RED	1
N3510	CWBAVR755N3510	4P WIRE ASS'Y(250MM, 2.0MM)	UL2547/1007#26(TA) 250mm 2mm 4P RED	1
N3511	CWBAVR755N3511	5P WIRE ASS'Y (350MM,2.0MM)	UL2725+ABE USB2.0 350mm 2mm 5P RED	1
N3516	CWB1B003080GN	3P WIRE ASS'Y(80MM, 2.0MM)	UL1007#26(TA) 80mm 2mm 3P RED	1
N3521	CJP10GB99ZY	WAFER	35237-1010 2.0mm 10P WHT	1
N3522	CJP19GB99ZM	WAFER(19P, AN 2MM)	35237-1910 2.0mm 19P WHT	1
N3523	CJP19GB99ZM	WAFER(19P, AN 2MM)	35237-1910 2.0mm 19P WHT	1
N3524	CJP16GB99ZM	WAFER(16P, AN 2MM)	35237-1610 2.0mm 16P WHT	1
N3525	CJP10GB99ZY	WAFER	35237-1010 2.0mm 10P WHT	1
N3526	CJP19GB99ZM	WAFER(19P, AN 2MM)	35237-1910 2.0mm 19P WHT	1
N3527	CJP07GB99ZY	HOUSING	35237-0710 2.0mm 7P WHT	1
N3528	CJP10GB99ZY	WAFER	35237-1010 2.0mm 10P WHT	1
P3508	CJP06GA47ZW	WAFER,2mm	GIL-S-6P-S2T2-EF 6P	1
P3512	CJP04GB48ZW	WAFER(4P, AN 2MM)	GIL-S-04P-S2L2-EF 4P	1
P3513	CJP05GA47ZW	WAFER,2mm	GIL-S-5P-S2T2-EF 5P	1
P3515	CJP03GB48ZW	WAFER (3PIN, AN, 2MM, JWT)	GIL-S-03P-S2L2-EF 3P	1
P3517	CJP03GB48ZW	WAFER (3PIN, AN, 2MM, JWT)	GIL-S-03P-S2L2-EF 3P	1
P3531	CJP10GA98ZY	WAFER	35336-1010 2.0mm 10P WHT	1
P3532	CJP19GA98ZM	WAFER(19P, ST 2MM)	35336-1910 2.0mm 19P WHT	1
P3533	CJP19GA98ZM	WAFER(19P, ST 2MM)	35336-1910 2.0mm 19P WHT	1
P3534	CJP16GA98ZM	WAFER(16P, ST 2MM)	35336-1610 2.0mm 16P WHT	1
P3535	CJP10GA98ZY	WAFER	35336-1010 2.0mm 10P WHT	1
P3536	CJP19GA98ZM	WAFER(19P, ST 2MM)	35336-1910 2.0mm 19P WHT	1

Ref. Designator	Part Number	Description		Qty
FRONT PCB ASSY		COP12040B		
P3537	CJP07GA98ZY	WAFER	35336-0710 2.0mm 7P WHT	1
P3538	CJP10GA98ZY	WAFER	35336-1010 2.0mm 10P WHT	1
P3540	CJP10GA98ZY	WAFER	35336-1010 2.0mm 10P WHT	1
RM3501	CRVKSM603TE2E	SENSOR , REMOCON	KSM-603TE2E	1
VR3501	CSR2A046Z	ENCODER , SW EC12E242803	EC121102F2B-HA1-004	1
L3502	CLZ9R011Z	BEAD , FERRITE (FCM2012HF-252T04 , 2.5 KOHM)	FCM2012HF-252T02 2500ohm SURFACE MT 201	1
L3503	CLZ9R012Z	BEAD , FERRITE(FCM2012CF-301T04 300ohm)	FCM2012CF-301T04 0805	1
SW3550	CSH1A001ZV	SWITCH		1
	CHG1A394	RUBBER , SENSOR AVR7550HD		1
	CBC1A162H61Z	BUTTON , POWER AVR7550HD		1
	CBT1A1066H61	BUTTON , 9KEY AVR7550HD		1
	CBT1A1067H61Z	BUTTON , 4 DIRECTION AVR7550HD		1
	CBT1A1068H61Z	BUTTON , OK AVR7550HD		1
	CBT1A1069	RETAINER, OK BUTTON AVR7550HD		1
	CBT1A1070B24	BUTTON , STANDBY AVR7550HD		1
	CDF1A020	SHAFT , DOOR AVR7550HD		4
	CDG1A026	GEAR , DAMPER(DP120)		1
	CGB1A158Y	BADGE , FRONT HARMAN/KARDON		1
	CGB1A210Z	BADGE , AVR7550HD		1
	CGL1A270	INDICATOR , STANDBY		1
	CGR1A488B24	DOOR , UNDER		1
	CGU1A416A25Z	WINDOW , FIP AVR7550HD		1
	CGW1A448R4ZB24	BODY , FRONT AVR7550HD		1
	CGX1A403Z	PLATE , DOOR AVR7550HD		1
	CGX1A404C66Z	VENNER , AL DOOR		1
	CGX1A405C66Z	VENNER , AL FRONT		1
	CHG1A385	RUBBER , DOOR AVR7550HD		2
	CJC1A009	MAGNET , AVR7550HD(10X10X4t)		2
	CMC1A334	PLATE , SPRING GND(0.2T) AVR7550HD		4
	CMD1A646	BRACKET , MAGNET AVR7550HD		2
	CMD1A647	BRACKET , SHAFT HINGE L AVR7550HD		2
	CMD1A648	BRACKET , SHAFT HINGE R AVR7550HD		2
	CMH1A284	HOLDER , MAGNET AVR7550HD		2
	CMZ1A129Z	FILTER , VFD AVR7550HD		1
	CPE1A010	OIL PAPER		1
	CTB3+8JFZR	SCREW		8
	CTW3+8JFZR	SCREW		26
	CWC4C4A21B250BBK	CABLE , CARD (21PIN, 250MM, 1.25MM, BLACK)		1
	CWB4FZ32600UKA	MOMS POWER SW WIRE ASS'Y		1
	CWB4FZ32600UK	3P(2wire) WIRE ASS'Y(600MM, 3.96MM)		1
MAIN HEAT SINK ASS'Y		CUP12037Y		
<i>Capacitors</i>				
C101	CCBS1H101KBT	CAP , CERAMIC(100PF/50V)	CH UP025 B101K-A-B Z	1
C102	CCBS1H101KBT	CAP , CERAMIC(100PF/50V)	CH UP025 B101K-A-B Z	1
C103	CCBS1H101KBT	CAP , CERAMIC(100PF/50V)	CH UP025 B101K-A-B Z	1
C104	CCBS1H101KBT	CAP , CERAMIC(100PF/50V)	CH UP025 B101K-A-B Z	1
C107	CCBS1H101KBT	CAP , CERAMIC(100PF/50V)	CH UP025 B101K-A-B Z	1
C108	CCBS1H101KBT	CAP , CERAMIC(100PF/50V)	CH UP025 B101K-A-B Z	1
C109	CCBS1H101KBT	CAP , CERAMIC(100PF/50V)	CH UP025 B101K-A-B Z	1
C110	CCBS1H101KBT	CAP , CERAMIC(100PF/50V)	CH UP025 B101K-A-B Z	1
C111	CCBS1H101KBT	CAP , CERAMIC(100PF/50V)	CH UP025 B101K-A-B Z	1
C112	CCBS1H101KBT	CAP , CERAMIC(100PF/50V)	CH UP025 B101K-A-B Z	1
C113	CCBS1H101KBT	CAP , CERAMIC(100PF/50V)	CH UP025 B101K-A-B Z	1
C114	CCBS1H101KBT	CAP , CERAMIC(100PF/50V)	CH UP025 B101K-A-B Z	1
C115	CCBS1H101KBT	CAP , CERAMIC(100PF/50V)	CH UP025 B101K-A-B Z	1
C116	CCBS1H101KBT	CAP , CERAMIC(100PF/50V)	CH UP025 B101K-A-B Z	1
C117	CCBS1H101KBT	CAP , CERAMIC(100PF/50V)	CH UP025 B101K-A-B Z	1
C118	CCBS1H101KBT	CAP , CERAMIC(100PF/50V)	CH UP025 B101K-A-B Z	1
C119	CCBS1H104ZFT	CAP , CERAMIC	0.1UF 50V Z	1
C120	CCBS1H104ZFT	CAP , CERAMIC	0.1UF 50V Z	1
C131	CCEA1VH101T	CAP , ELECT	100UF 35V	1
C132	CCBS1H104ZFT	CAP , CERAMIC	0.1UF 50V Z	1
C133	CCEA1VH101T	CAP , ELECT	100UF 35V	1
C134	CCBS1H104ZFT	CAP , CERAMIC	0.1UF 50V Z	1
C135	CCEA1HH100T	CAP , ELECT	10UF 50V	1
C136	CCEA1HH100T	CAP , ELECT	10UF 50V	1
C137	CCEA1HH100T	CAP , ELECT	10UF 50V	1
C138	CCEA1VH101T	CAP , ELECT	100UF 35V	1

Ref. Designator	Part Number	Description	Qty
MAIN HEAT SINK ASS'Y		CUP12037Y	
C139	CCBS1H104ZFT	CAP , CERAMIC	0.1UF 50V Z
C140	CCEA1HH100T	CAP , ELECT	10UF 50V
C141	CCBS1H104ZFT	CAP , CERAMIC	0.1UF 50V Z
C156	HCQI1H473JZT	CAP , MYLAR	0.047UF 50V J
C157	HCQI1H473JZT	CAP , MYLAR	0.047UF 50V J
C158	HCQI1H473JZT	CAP , MYLAR	0.047UF 50V J
C159	HCQI1H473JZT	CAP , MYLAR	0.047UF 50V J
C160	HCQI1H473JZT	CAP , MYLAR	0.047UF 50V J
C161	HCQI1H473JZT	CAP , MYLAR	0.047UF 50V J
C181	CCEA1CH101T	CAP , ELECT	100UF 16V
C203	CCBS1H104ZFT	CAP , CERAMIC	0.1UF 50V Z
C205	CCBS1H101KBT	CAP , CERAMIC(100PF/50V)	CH UP025 B101K-A-B Z
C206	CCEA1VH101T	CAP , ELECT	100UF 35V
C207	CCEA1HH4R7T	CAP , ELECT	4.7UF 50V
C210	CCEA1HH1R0T	CAP , ELECT	1UF 50V
C211	CCEA2AH100TS	CAP , ELECT(KRM, 100V/10UF, 6.3x11)	KRM, 100V/10UF, 6.3X11
C212	CCBS1H104ZFT	CAP , CERAMIC	0.1UF 50V Z
C214	CCBS1H104ZFT	CAP , CERAMIC	0.1UF 50V Z
C225	CCFT1H104ZF	CAP , SEMICONDUCTOR	0.1UF 50V Z
C226	CCEA1HH100T	CAP , ELECT	10UF 50V
C227	CCBS1H104ZFT	CAP , CERAMIC	0.1UF 50V Z
C228	CCEA1VH101T	CAP , ELECT	100UF 35V
C229	CCBS1H104ZFT	CAP , CERAMIC	0.1UF 50V Z
C230	CCBS1H104ZFT	CAP , CERAMIC	0.1UF 50V Z
C231	CCBS1H104ZFT	CAP , CERAMIC	0.1UF 50V Z
C301	CCEA1HH100T	CAP , ELECT	10UF 50V
C302	CCEA1HH100T	CAP , ELECT	10UF 50V
C307	CCBS1H271KBT	CAP , CERAMIC(270PF/50V)	CH UP025 B271K-A-B Z
C308	CCBS1H271KBT	CAP , CERAMIC(270PF/50V)	CH UP025 B271K-A-B Z
C309	CCEA1VH101T	CAP , ELECT	100UF 35V
C310	CCEA1VH101T	CAP , ELECT	100UF 35V
C313	CCBS1H271KBT	CAP , CERAMIC(270PF/50V)	CH UP025 B271K-A-B Z
C314	CCBS1H271KBT	CAP , CERAMIC(270PF/50V)	CH UP025 B271K-A-B Z
C315	CCCT1H030CC	CAP , CERAMIC	3PF 50V C
C316	CCCT1H030CC	CAP , CERAMIC	3PF 50V C
C317	CCKT1H181KB	CAP , CERAMIC	180PF 50V K
C318	CCKT1H181KB	CAP , CERAMIC	180PF 50V K
C319	CCEA2AH100TS	CAP , ELECT(KRM, 100V/10UF, 6.3x11)	KRM, 100V/10UF, 6.3X11
C320	CCEA2AH100TS	CAP , ELECT(KRM, 100V/10UF, 6.3x11)	KRM, 100V/10UF, 6.3X11
C321	CCEA2AH100TS	CAP , ELECT(KRM, 100V/10UF, 6.3x11)	KRM, 100V/10UF, 6.3X11
C322	CCEA2AH100TS	CAP , ELECT(KRM, 100V/10UF, 6.3x11)	KRM, 100V/10UF, 6.3X11
C323	CCME2A683JXT	CAP , METALIZED FILM (0.068UF/100V J)	0.068UF 63V +5% CPM
C324	CCME2A683JXT	CAP , METALIZED FILM (0.068UF/100V J)	0.068UF 63V +5% CPM
C325	HCQI1H104JZT	CAP , MYLAR	0.1UF 50V J
C326	HCQI1H104JZT	CAP , MYLAR	0.1UF 50V J
C327	HCQI1H104JZT	CAP , MYLAR	0.1UF 50V J
C328	HCQI1H104JZT	CAP , MYLAR	0.1UF 50V J
C329	CCKT1H222KB	CAP , CERAMIC	2200PF 50V K
C330	CCKT1H222KB	CAP , CERAMIC	2200PF 50V K
C331	CCEA1AH221T	CAP , ELECT	220UF 10V
C332	CCEA1AH221T	CAP , ELECT	220UF 10V
C333	CCFT1H103ZF	CAP , CERAMIC	0.01UF 50V Z
C335	CCFT1H103ZF	CAP , CERAMIC	0.01UF 50V Z
C336	CCFT1H103ZF	CAP , CERAMIC	0.01UF 50V Z
C401	CCEA1HH100T	CAP , ELECT	10UF 50V
C402	CCEA1HH100T	CAP , ELECT	10UF 50V
C403	CCBS1H271KBT	CAP , CERAMIC(270PF/50V)	CH UP025 B271K-A-B Z
C404	CCBS1H271KBT	CAP , CERAMIC(270PF/50V)	CH UP025 B271K-A-B Z
C405	CCEA1VH101T	CAP , ELECT	100UF 35V
C406	CCEA1VH101T	CAP , ELECT	100UF 35V
C407	CCEA1AH221T	CAP , ELECT	220UF 10V
C408	CCEA1AH221T	CAP , ELECT	220UF 10V
C409	CCCT1H030CC	CAP , CERAMIC	3PF 50V C
C410	CCCT1H030CC	CAP , CERAMIC	3PF 50V C
C411	CCKT1H181KB	CAP , CERAMIC	180PF 50V K
C412	CCKT1H181KB	CAP , CERAMIC	180PF 50V K
C413	CCEA2AH100TS	CAP , ELECT(KRM, 100V/10UF, 6.3x11)	KRM, 100V/10UF, 6.3X11
C414	CCEA2AH100TS	CAP , ELECT(KRM, 100V/10UF, 6.3x11)	KRM, 100V/10UF, 6.3X11
C415	CCEA2AH100TS	CAP , ELECT(KRM, 100V/10UF, 6.3x11)	KRM, 100V/10UF, 6.3X11
C416	CCEA2AH100TS	CAP , ELECT(KRM, 100V/10UF, 6.3x11)	KRM, 100V/10UF, 6.3X11
C417	HCQI1H104JZT	CAP , MYLAR	0.1UF 50V J

Ref. Designator	Part Number	Description		Qty
MAIN HEAT SINK ASS'Y		CUP12037Y		
C418	HCQ11H104JZT	CAP , MYLAR	0.1UF 50V J	1
C419	HCQ11H104JZT	CAP , MYLAR	0.1UF 50V J	1
C420	HCQ11H104JZT	CAP , MYLAR	0.1UF 50V J	1
C425	CCKT1H222KB	CAP , CERAMIC	2200PF 50V K	1
C426	CCKT1H222KB	CAP , CERAMIC	2200PF 50V K	1
C429	CCEA1HH100T	CAP , ELECT	10UF 50V	1
C430	CCME2A683JXT	CAP , METALIZED FILM (0.068UF/100V J)	0.068UF 63V +5% CPM	1
C431	CCME2A683JXT	CAP , METALIZED FILM (0.068UF/100V J)	0.068UF 63V +5% CPM	1
C432	CCEA1EH471T	CAP , ELECT	470UF 25V	1
C433	CCBS1H103ZFT	CAP , CERAMIC	0.01UF 50V Z	1
C434	CCFT1H103ZF	CAP , CERAMIC	0.01UF 50V Z	1
C441	CCBS1H271KBT	CAP , CERAMIC(270PF/50V)	CH UP025 B271K-A-B Z	1
C442	CCBS1H271KBT	CAP , CERAMIC(270PF/50V)	CH UP025 B271K-A-B Z	1
C151	CCET63VKL5153MS67	CAP , ELECT (15000UF/63V M 40X50 P10mm)	KL5-63V153MS67 , KOSHIN	1
C152	CCET63VKL5153MS67	CAP , ELECT (15000UF/63V M 40X50 P10mm)	KL5-63V153MS67 , KOSHIN	1
C153	CCEA1VH222E	CAP , ELECT	2200uF 35V +20% 85C	1
C154	CCEA1VH222E	CAP , ELECT	2200uF 35V +20% 85C	1
C155	CCEA1HH222ES	CAP , ELECT(KRM, 50V/2200UF,105C, 16X31.5)	KRM, 50V/2200UF,105C, 16X31.5	1
C223	CCEA1CH103E	CAP , ELECT	10000uF 16V M 18x35.5	1
C224	CCEA1CH103E	CAP , ELECT	10000uF 16V M 18x35.5	1
C303	CCEA1JH471E	CAP , ELECT	470uF 63V +20% 85C	1
C304	CCEA1JH471E	CAP , ELECT	470uF 63V +20% 85C	1
C305	CCEA1JH471E	CAP , ELECT	470uF 63V +20% 85C	1
C306	CCEA1JH471E	CAP , ELECT	470uF 63V +20% 85C	1
C421	CCEA1JH471E	CAP , ELECT	470uF 63V +20% 85C	1
C422	CCEA1JH471E	CAP , ELECT	470uF 63V +20% 85C	1
C423	CCEA1JH471E	CAP , ELECT	470uF 63V +20% 85C	1
C424	CCEA1JH471E	CAP , ELECT	470uF 63V +20% 85C	1
<i>Semiconductors</i>				
IC230	CVIKIA578R033PI	I.C , REGULATOR 5A (TO-220IS-4)	KIA578R033PI	1
IC231	HVIKIA7805API	REGULATOR, +5V	7805API (KEC)	1
IC232	HVIKIA278R06PI	REGULATOR (6V OUTPUT LOW DROP)	KIA7805API TO-220IS	1
Q329	HVT2SA1859A	4 TERM 2A OUTPUT VOLTAGE REG +6V	KIA278R06PI TO-220IS-4	1
Q330	HVT2SA1859A	TRANSISTOR , DRIVER PNP	2SA1859A P -2.0A	1
Q331	HVT2SC4883A	TRANSISTOR , DRIVER NPN	2SC4883A N 2.0A	1
Q332	HVT2SC4883A	TRANSISTOR , DRIVER NPN	2SC4883A N 2.0A	1
Q333	CVT2SC5358R	TRANSISTOR , POWER(NPN 230V,15A, 80W)	2SC5358-R(AC,F)	1
Q334	CVT2SC5358R	TRANSISTOR , POWER(NPN 230V,15A, 80W)	2SC5358-R(AC,F)	1
Q335	CVT2SA1986R	TRANSISTOR , POWER(NPN 230V,15A, 80W)	2SA1986-R(AC,F)	1
Q336	CVT2SA1986R	TRANSISTOR , POWER(NPN 230V,15A, 80W)	2SA1986-R(AC,F)	1
Q433	HVT2SA1859A	TRANSISTOR , DRIVER PNP	2SA1859A P -2.0A	1
Q434	HVT2SA1859A	TRANSISTOR , DRIVER PNP	2SA1859A P -2.0A	1
Q435	HVT2SC4883A	TRANSISTOR , DRIVER NPN	2SC4883A N 2.0A	1
Q436	HVT2SC4883A	TRANSISTOR , DRIVER NPN	2SC4883A N 2.0A	1
Q437	CVT2SC5358R	TRANSISTOR , POWER(NPN 230V,15A, 80W)	2SC5358-R(AC,F)	1
Q438	CVT2SC5358R	TRANSISTOR , POWER(NPN 230V,15A, 80W)	2SC5358-R(AC,F)	1
Q439	CVT2SA1986R	TRANSISTOR , POWER(NPN 230V,15A, 80W)	2SA1986-R(AC,F)	1
Q440	CVT2SA1986R	TRANSISTOR , POWER(NPN 230V,15A, 80W)	2SA1986-R(AC,F)	1
D104	HVD1N4148T	DIODE	1N4148 100V 150E-3A	1
D131	HVD1N4007T	DIODE	1N4007 1000V 1A DO-41	1
D132	HVD1N4007T	DIODE	1N4007 1000V 1A DO-41	1
D133	HVD1N4007T	DIODE	1N4007 1000V 1A DO-41	1
D134	HVD1N4148T	DIODE	1N4148 100V 150E-3A	1
D135	HVD1N4007T	DIODE	1N4007 1000V 1A DO-41	1
D151	HVD1N4148T	DIODE	1N4148 100V 150E-3A	1
D152	HVD1N4148T	DIODE	1N4148 100V 150E-3A	1
D153	HVD1N4148T	DIODE	1N4148 100V 150E-3A	1
D204	HVDMTZJ12BT	DIODE , ZENER	MTZ J 12B 12V 500mW DO-34	1
D205	HVD1N4148T	DIODE	1N4148 100V 150E-3A	1
D206	HVD1N4148T	DIODE	1N4148 100V 150E-3A	1
D207	CVDZJ3.3BT	DIODE , ZENER	ZJ3.3B 1/2W	1
D210	HVD1N5819T	DIODE , SCHOTTKY	1N5819	1
D211	CVD1N4003ST	DIODE , RECT	1N4003	1
D301	HVD1N4148T	DIODE	1N4148	1
D302	HVD1N4148T	DIODE	1N4148	1
D303	HVD1N4148T	DIODE	1N4148	1
D304	HVD1N4148T	DIODE	1N4148	1
D305	HVD1N4148T	DIODE	1N4148	1
D306	HVD1N4148T	DIODE	1N4148	1

Ref. Designator	Part Number	Description		Qty
MAIN HEAT SINK ASS'Y		CUP12037Y		
D307	HVD1N4148T	DIODE	1N4148	1
D308	HVD1N4148T	DIODE	1N4148	1
D401	HVD1N4148T	DIODE	1N4148	1
D402	HVD1N4148T	DIODE	1N4148	1
D403	HVD1N4148T	DIODE	1N4148	1
D404	HVD1N4148T	DIODE	1N4148	1
D405	HVD1N4148T	DIODE	1N4148	1
D406	HVD1N4148T	DIODE	1N4148	1
D407	HVD1N4148T	DIODE	1N4148	1
D408	HVD1N4148T	DIODE	1N4148	1
D409	HVD1N4148T	DIODE	1N4148	1
D410	HVD1N4148T	DIODE	1N4148	1
D411	HVD1N4148T	DIODE	1N4148	1
D412	HVD1N4148T	DIODE	1N4148	1
Q131	HVTKRC107MT	TRANSISTOR NPN	KRC107M	1
Q181	HVTKTA1268GRT	TRANSISTOR PNP	KTA1268GR	1
Q182	HVTKTA1024YT	TRANSISTOR PNP	KTA1024 Y P 50MIOA -150V	1
Q201	HVTKRC107MT	TRANSISTOR NPN	KRC107M	1
Q301	HVTKTC3200GRT	TRANSISTOR NPN	KTC3200GR	1
Q302	HVTKTC3200GRT	TRANSISTOR NPN	KTC3200GR	1
Q303	HVTKTC3200GRT	TRANSISTOR NPN	KTC3200GR	1
Q304	HVTKTC3200GRT	TRANSISTOR NPN	KTC3200GR	1
Q305	HVTKTC3200GRT	TRANSISTOR NPN	KTC3200GR	1
Q306	HVTKTC3200GRT	TRANSISTOR NPN	KTC3200GR	1
Q307	HVTKTC3198YT	TRANSISTOR NPN	KTC3198Y	1
Q308	HVTKTC3198YT	TRANSISTOR NPN	KTC3198Y	1
Q309	CVT2SA1145YFT	TRANSISTOR , PNP HFE:120-240 TO-92L	2SA1145-Y(F) TO-92	1
Q310	CVT2SA1145YFT	TRANSISTOR , PNP HFE:120-240 TO-92L	2SA1145-Y(F) TO-92	1
Q311	HVTKTA1268GRT	TRANSISTOR PNP	KTA1268GR	1
Q312	HVTKTA1268GRT	TRANSISTOR PNP	KTA1268GR	1
Q313	HVTKTC3200GRT	TRANSISTOR NPN	KTC3200GR	1
Q314	HVTKTC3200GRT	TRANSISTOR NPN	KTC3200GR	1
Q315	HVTKTA1024YT	TRANSISTOR PNP	KTA1024 Y P 50MIOA -150V	1
Q316	HVTKTA1024YT	TRANSISTOR PNP	KTA1024 Y P 50MIOA -150V	1
Q317	HVTKTC3206YAT	TRANSISTOR HIGH VOLTAGE NPN	KTC3206 Y N 50MIOA 150V	1
Q318	HVTKTC3206YAT	TRANSISTOR HIGH VOLTAGE NPN	KTC3206 Y N 50MIOA 150V	1
Q319	HVTKTA1024YT	TRANSISTOR PNP	KTA1024 Y P 50MIOA -150V	1
Q320	HVTKTA1024YT	TRANSISTOR PNP	KTA1024 Y P 50MIOA -150V	1
Q321	HVTKTC3206YAT	TRANSISTOR HIGH VOLTAGE NPN	KTC3206 Y N 50MIOA 150V	1
Q322	HVTKTC3206YAT	TRANSISTOR HIGH VOLTAGE NPN	KTC3206 Y N 50MIOA 150V	1
Q337	HVTKTC3200GRT	TRANSISTOR NPN	KTC3200GR	1
Q338	HVTKTC3200GRT	TRANSISTOR NPN	KTC3200GR	1
Q401	HVTKTC3200GRT	TRANSISTOR NPN	KTC3200GR	1
Q402	HVTKTC3200GRT	TRANSISTOR NPN	KTC3200GR	1
Q403	HVTKTC3200GRT	TRANSISTOR NPN	KTC3200GR	1
Q404	HVTKTC3200GRT	TRANSISTOR NPN	KTC3200GR	1
Q405	HVTKTC3200GRT	TRANSISTOR NPN	KTC3200GR	1
Q406	HVTKTC3200GRT	TRANSISTOR NPN	KTC3200GR	1
Q407	HVTKTC3198YT	TRANSISTOR NPN	KTC3198Y	1
Q408	HVTKTC3198YT	TRANSISTOR NPN	KTC3198Y	1
Q409	HVTKTC3200GRT	TRANSISTOR NPN	KTC3200GR	1
Q410	HVTKTA1268GRT	TRANSISTOR PNP	KTA1268GR	1
Q411	CVT2SA1145YFT	TRANSISTOR , PNP HFE:120-240 TO-92L	2SA1145-Y(F) TO-92	1
Q412	CVT2SA1145YFT	TRANSISTOR , PNP HFE:120-240 TO-92L	2SA1145-Y(F) TO-92	1
Q413	HVTKTA1268GRT	TRANSISTOR PNP	KTA1268GR	1
Q414	HVTKTA1268GRT	TRANSISTOR PNP	KTA1268GR	1
Q415	HVTKTC3200GRT	TRANSISTOR NPN	KTC3200GR	1
Q416	HVTKTC3200GRT	TRANSISTOR NPN	KTC3200GR	1
Q417	HVTKTA1024YT	TRANSISTOR PNP	KTA1024 Y P 50MIOA -150V	1
Q418	HVTKTA1024YT	TRANSISTOR PNP	KTA1024 Y P 50MIOA -150V	1
Q419	HVTKTC3206YAT	TRANSISTOR HIGH VOLTAGE NPN	KTC3206 Y N 50MIOA 150V	1
Q420	HVTKTC3206YAT	TRANSISTOR HIGH VOLTAGE NPN	KTC3206 Y N 50MIOA 150V	1
Q421	HVTKTA1024YT	TRANSISTOR PNP	KTA1024 Y P 50MIOA -150V	1
Q422	HVTKTA1024YT	TRANSISTOR PNP	KTA1024 Y P 50MIOA -150V	1
Q423	HVTKTC3206YAT	TRANSISTOR HIGH VOLTAGE NPN	KTC3206 Y N 50MIOA 150V	1
Q424	HVTKTC3206YAT	TRANSISTOR HIGH VOLTAGE NPN	KTC3206 Y N 50MIOA 150V	1
Q425	HVTKTC3200GRT	TRANSISTOR NPN	KTC3200GR	1
Q426	HVTKTC3198YT	TRANSISTOR NPN	KTC3198Y	1
Q441	HVTKTC3198YT	TRANSISTOR NPN	KTC3198Y	1
Q442	HVTKTA1024YT	TRANSISTOR PNP	KTA1024 Y P 50MIOA -150V	1
Q443	HVTKRC107MT	TRANSISTOR NPN	KRC107M	1

Ref. Designator	Part Number	Description		Qty
MAIN HEAT SINK ASS'Y		CUP12037Y		
IC131	HVIKIA7812API	I.C , REGULATOR +12V	KIA78XXAPI	1
IC132	HVIKIA278R12PI	REGULATOR(12V OUTPUT LOW DROP)	KIA278R12PI	1
IC133	CVIKIA278R15PI	I.C , REGULATOR(15V OUTPUT LOW DROP)	KIA278R15PI-U/P	1
IC134	CVIKIA7915PI	I.C , REGULATOR(15V, TO-220AB)	KIA7915PI	1
IC135	CVIKIA7824API	I.C , VOL-REGULATOR(24V TO-220IS)	KIA7824API	1
IC136	HVIKIA7812API	I.C , REGULATOR +12V	KIA78XXAPI	1
IC137	CVIKIA7824API	I.C , VOL-REGULATOR(24V TO-220IS)	KIA7824API	1
D140	CVD2W04MMFRS2	DIODE , BRIDGE(RC-2 KINK TYPE)	2W04MMFRS2 , DELTA	1
D141	CVD2W04MMFRS2	DIODE , BRIDGE(RC-2 KINK TYPE)	2W04MMFRS2 , DELTA	1
IC138	HVINJM2068DD	I.C , DUAL OP AMP	NJM2068DD	1
IC233	CVILM19CIZ2.4V	I.C , TEMP SENSOR	LM19CIZ2.4V , NATIONAL(T I)	1
Q231	HVTKTC3114A	TRANSISTOR , BIAS NPN	KTC3114A	1
Q232	HVTKTC3114A	TRANSISTOR , BIAS NPN	KTC3114A	1
Q233	HVTKTC3114A	TRANSISTOR , BIAS NPN	KTC3114A	1
Q234	HVTKTC3114A	TRANSISTOR , BIAS NPN	KTC3114A	1
Q323	HVTKTC3423Y	TRANSISTOR , PRE DRIVE NPN	KTC3423Y	1
Q324	HVTKTC3423Y	TRANSISTOR , PRE DRIVE NPN	KTC3423Y	1
Q327	HVTKTA1360Y	TRANSISTOR , PRE DRIVE PNP	KTA1360Y	1
Q328	HVTKTA1360Y	TRANSISTOR , PRE DRIVE PNP	KTA1360Y	1
Q429	HVTKTC3423Y	TRANSISTOR , PRE DRIVE NPN	KTC3423Y	1
Q430	HVTKTC3423Y	TRANSISTOR , PRE DRIVE NPN	KTC3423Y	1
Q431	HVTKTA1360Y	TRANSISTOR , PRE DRIVE PNP	KTA1360Y	1
Q432	HVTKTA1360Y	TRANSISTOR , PRE DRIVE PNP	KTA1360Y	1
<i>Resistors</i>				
R101	CRD20TJ471T	RES , CARBON	470 OHM 1/5W J	1
R102	CRD20TJ471T	RES , CARBON	470 OHM 1/5W J	1
R105	CRD20TJ471T	RES , CARBON	470 OHM 1/5W J	1
R106	CRD20TJ471T	RES , CARBON	470 OHM 1/5W J	1
R109	CRD20TJ471T	RES , CARBON	470 OHM 1/5W J	1
R110	CRD20TJ471T	RES , CARBON	470 OHM 1/5W J	1
R113	CRD20TJ471T	RES , CARBON	470 OHM 1/5W J	1
R114	CRD20TJ471T	RES , CARBON	470 OHM 1/5W J	1
R121	CRD20TJ103T	RES , CARBON	10K OHM 1/5W J	1
R140	CRD20TJ102T	RES , CARBON	1K OHM 1/5W J	1
R141	CRD20TJ273T	RES , CARBON	27K OHM 1/5W J	1
R142	CRD20TJ333T	RES , CARBON	33K OHM 1/5W J	1
R143	CRD20TJ333T	RES , CARBON	33K OHM 1/5W J	1
R150	CRD20TJ473T	RES , CARBON	47K OHM 1/5W J	1
R151	CRD20TJ100T	RES , CARBON	10 OHM 1/5W J	1
R152	CRD20TJ1R0T	RES , CARBON	1 OHM 1/5W J	1
R194	CRD20TJ100T	RES , CARBON	10 OHM 1/5W J	1
R195	CRD20TJ100T	RES , CARBON	10 OHM 1/5W J	1
R196	CRD20TJ100T	RES , CARBON	10 OHM 1/5W J	1
R197	CRD20TJ100T	RES , CARBON	10 OHM 1/5W J	1
R207	CRD20TJ104T	RES , CARBON	100K OHM 1/5W J	1
R209	CRD20TJ273T	RES , CARBON	27K OHM 1/5W J	1
R211	CRD20TJ102T	RES , CARBON	1K OHM 1/5W J	1
R214	CRD20TJ104T	RES , CARBON	100K OHM 1/5W J	1
R215	CRD20TJ221T	RES , CARBON	220 OHM 1/5W J	1
R216	CRD20TJ104T	RES , CARBON	100K OHM 1/5W J	1
R217	CRD20TJ104T	RES , CARBON	100K OHM 1/5W J	1
R218	CRD20TJ104T	RES , CARBON	100K OHM 1/5W J	1
R219	CRD20TJ104T	RES , CARBON	100K OHM 1/5W J	1
R220	CRD20TJ104T	RES , CARBON	100K OHM 1/5W J	1
R223	CRD20TJ513T	RES , CARBON	51K ohm 1/4W 5%	1
R224	CRD20TJ274T	RES , CARBON	270K ohm 1/4W 5%	1
R225	CRD20TJ333T	RES , CARBON	33K OHM 1/5W J	1
R231	CRD20TJ103T	RES , CARBON	10K OHM 1/5W J	1
R234	CRD20TJ103T	RES , CARBON	10K OHM 1/5W J	1
R235	CRD20TJ101T	RES , CARBON	100 OHM 1/5W J	1
R236	CRD20TJ471T	RES , CARBON	470 OHM 1/5W J	1
R237	CRD20TJ821T	RES , CARBON	820 OHM 1/5W J	1
R238	CRD20TF2801T	RES , CARBON	2K8 ohm 1/4W 5%	1
R239	CRD20TJ821T	RES , CARBON	820 OHM 1/5W J	1
R240	CRD20TF2801T	RES , CARBON	2K8 ohm 1/4W 5%	1
R241	CRD20TJ821T	RES , CARBON	820 OHM 1/5W J	1
R242	CRD20TF2801T	RES , CARBON	2K8 ohm 1/4W 5%	1
R243	CRD20TJ821T	RES , CARBON	820 OHM 1/5W J	1
R244	CRD20TF2801T	RES , CARBON	2K8 ohm 1/4W 5%	1

Ref. Designator	Part Number	Description	Qty
MAIN HEAT SINK ASS'Y		CUP12037Y	
R301	CRD20TJ331T	RES , CARBON	330 OHM 1/5W J
R302	CRD20TJ331T	RES , CARBON	330 OHM 1/5W J
R305	CRD20TJ333T	RES , CARBON	33K OHM 1/5W J
R306	CRD20TJ333T	RES , CARBON	33K OHM 1/5W J
R307	CRD20TJ433T	RES , CARBON	43K OHM 1/5W J
R308	CRD20TJ433T	RES , CARBON	43K OHM 1/5W J
R309	CRD20TJ104T	RES , CARBON	100K OHM 1/5W J
R310	CRD20TJ104T	RES , CARBON	100K OHM 1/5W J
R311	CRD20TJ162T	RES , CARBON	1K6 ohm 1/4W 5%
R312	CRD20TJ162T	RES , CARBON	1K6 ohm 1/4W 5%
R313	CRD20TJ162T	RES , CARBON	1K6 ohm 1/4W 5%
R314	CRD20TJ162T	RES , CARBON	1K6 ohm 1/4W 5%
R315	CRD20TJ471T	RES , CARBON	470 OHM 1/5W J
R316	CRD20TJ471T	RES , CARBON	470 OHM 1/5W J
R317	CRD20TJ221T	RES , CARBON	220 OHM 1/5W J
R318	CRD20TJ221T	RES , CARBON	220 OHM 1/5W J
R319	CRD20TJ221T	RES , CARBON	220 OHM 1/5W J
R320	CRD20TJ221T	RES , CARBON	220 OHM 1/5W J
R321	CRD20TJ221T	RES , CARBON	220 OHM 1/5W J
R322	CRD20TJ221T	RES , CARBON	220 OHM 1/5W J
R323	CRD20TJ561T	RES , CARBON	560 OHM 1/5W J
R324	CRD20TJ561T	RES , CARBON	560 OHM 1/5W J
R325	CRD20TJ561T	RES , CARBON	560 OHM 1/5W J
R326	CRD20TJ561T	RES , CARBON	560 OHM 1/5W J
R327	CRD20TF3302T	RES , CARBON	33K0ohm +1% 1/4W SMALL TYPE
R328	CRD20TF3302T	RES , CARBON	33K0ohm +1% 1/4W SMALL TYPE
R329	CRD20TJ561T	RES , CARBON	560 OHM 1/5W J
R330	CRD20TJ561T	RES , CARBON	560 OHM 1/5W J
R331	CRD20TF1401T	RES , CARBON	1.4K OHM 1% 1/6W
R332	CRD20TF1401T	RES , CARBON	1.4K OHM 1% 1/6W
R333	CRD20TJ561T	RES , CARBON	560 OHM 1/5W J
R334	CRD20TJ561T	RES , CARBON	560 OHM 1/5W J
R335	CRD20TJ561T	RES , CARBON	560 OHM 1/5W J
R336	CRD20TJ561T	RES , CARBON	560 OHM 1/5W J
R337	CRD20TJ561T	RES , CARBON	560 OHM 1/5W J
R338	CRD20TJ561T	RES , CARBON	560 OHM 1/5W J
R339	CRD20TJ201T	RES , CARBON	200 OHM 1/5 W
R340	CRD20TJ201T	RES , CARBON	200 OHM 1/5 W
R341	CRD20TJ153T	RES , CARBON	15K OHM 1/5W J
R342	CRD20TJ153T	RES , CARBON	15K OHM 1/5W J
R343	CRD20TJ153T	RES , CARBON	15K OHM 1/5W J
R344	CRD20TJ153T	RES , CARBON	15K OHM 1/5W J
R345	CRD20TJ201T	RES , CARBON	200 OHM 1/5 W
R346	CRD20TJ201T	RES , CARBON	200 OHM 1/5 W
R347	CRD20TJ201T	RES , CARBON	200 OHM 1/5 W
R348	CRD20TJ201T	RES , CARBON	200 OHM 1/5 W
R349	CRD20TJ201T	RES , CARBON	200 OHM 1/5 W
R350	CRD20TJ201T	RES , CARBON	200 OHM 1/5 W
R351	CRD50FJ100T	RES , CARBON	10 ohm 1/2W 5%
R352	CRD50FJ100T	RES , CARBON	10 ohm 1/2W 5%
R353	CRD20TJ101T	RES , CARBON	100 OHM 1/5W J
R354	CRD20TJ101T	RES , CARBON	100 OHM 1/5W J
R363	CRD20TJ150T	RES , CARBON	15 OHM 1/5W J
R364	CRD20TJ150T	RES , CARBON	15 OHM 1/5W J
R365	CRD20TJ150T	RES , CARBON	15 OHM 1/5W J
R366	CRD20TJ150T	RES , CARBON	15 OHM 1/5W J
R367	CRD50FJ100T	RES , CARBON	10 ohm 1/2W 5%
R368	CRD50FJ100T	RES , CARBON	10 ohm 1/2W 5%
R369	CRD20TJ101T	RES , CARBON	100 OHM 1/5W J
R370	CRD20TJ101T	RES , CARBON	100 OHM 1/5W J
R371	CRD20TJ2R2T	RES , CARBON	2.2 OHM 1/5W J
R372	CRD20TJ2R2T	RES , CARBON	2.2 OHM 1/5W J
R373	CRD20TJ2R2T	RES , CARBON	2.2 OHM 1/5W J
R374	CRD20TJ2R2T	RES , CARBON	2.2 OHM 1/5W J
R375	CRD20TJ820T	RES , CARBON	82 OHM 1/5W J
R376	CRD20TJ820T	RES , CARBON	82 OHM 1/5W J
R380	CRD20TJ152T	RES , CARBON	1.5K OHM 1/5W J
R381	CRD20TJ152T	RES , CARBON	1.5K OHM 1/5W J
R382	CRD20TJ393T	RES , CARBON	39K ohm 1/4W 5%
R383	CRD20TJ393T	RES , CARBON	39K ohm 1/4W 5%
R384	CRD20TJ153T	RES , CARBON	15K OHM 1/5W J

Ref. Designator	Part Number	Description	Qty
MAIN HEAT SINK ASS'Y		CUP12037Y	
R385	CRD20TJ153T	RES , CARBON	15K OHM 1/5W J
R386	CRD20TJ152T	RES , CARBON	1.5K OHM 1/5W J
R387	CRD20TJ152T	RES , CARBON	1.5K OHM 1/5W J
R388	CRD20TJ100T	RES , CARBON	10 OHM 1/5W J
R389	CRD20TJ100T	RES , CARBON	10 OHM 1/5W J
R390	CRD20TJ223T	RES , CARBON	22K OHM 1/5W J
R391	CRD20TJ223T	RES , CARBON	22K OHM 1/5W J
R399	CRD20TJ101T	RES , CARBON	100 OHM 1/5W J
R401	CRD20TJ331T	RES , CARBON	330 OHM 1/5W J
R402	CRD20TJ331T	RES , CARBON	330 OHM 1/5W J
R403	CRD20TJ333T	RES , CARBON	33K OHM 1/5W J
R404	CRD20TJ333T	RES , CARBON	33K OHM 1/5W J
R405	CRD20TJ162T	RES , CARBON	1K6 ohm 1/4W 5%
R406	CRD20TJ162T	RES , CARBON	1K6 ohm 1/4W 5%
R407	CRD20TJ162T	RES , CARBON	1K6 ohm 1/4W 5%
R408	CRD20TJ162T	RES , CARBON	1K6 ohm 1/4W 5%
R409	CRD20TJ221T	RES , CARBON	220 OHM 1/5W J
R410	CRD20TJ221T	RES , CARBON	220 OHM 1/5W J
R411	CRD20TJ221T	RES , CARBON	220 OHM 1/5W J
R412	CRD20TJ221T	RES , CARBON	220 OHM 1/5W J
R413	CRD20TJ221T	RES , CARBON	220 OHM 1/5W J
R414	CRD20TJ221T	RES , CARBON	220 OHM 1/5W J
R415	CRD20TJ433T	RES , CARBON	43K OHM 1/5W J
R416	CRD20TJ433T	RES , CARBON	43K OHM 1/5W J
R417	CRD20TF3302T	RES , CARBON	33K0ohm +1% 1/4W SMALL TYPE
R418	CRD20TF3302T	RES , CARBON	33K0ohm +1% 1/4W SMALL TYPE
R419	CRD20TF1401T	RES , CARBON	1.4K OHM 1% 1/6W
R420	CRD20TF1401T	RES , CARBON	1.4K OHM 1% 1/6W
R421	CRD20TJ561T	RES , CARBON	560 OHM 1/5W J
R422	CRD20TJ561T	RES , CARBON	560 OHM 1/5W J
R423	CRD20TJ561T	RES , CARBON	560 OHM 1/5W J
R424	CRD20TJ561T	RES , CARBON	560 OHM 1/5W J
R425	CRD20TJ561T	RES , CARBON	560 OHM 1/5W J
R426	CRD20TJ561T	RES , CARBON	560 OHM 1/5W J
R427	CRD20TJ561T	RES , CARBON	560 OHM 1/5W J
R428	CRD20TJ561T	RES , CARBON	560 OHM 1/5W J
R429	CRD20TJ561T	RES , CARBON	560 OHM 1/5W J
R430	CRD20TJ561T	RES , CARBON	560 OHM 1/5W J
R431	CRD20TJ561T	RES , CARBON	560 OHM 1/5W J
R432	CRD20TJ561T	RES , CARBON	560 OHM 1/5W J
R433	CRD20TJ201T	RES , CARBON	200 OHM 1/5 W
R434	CRD20TJ201T	RES , CARBON	200 OHM 1/5 W
R435	CRD20TJ201T	RES , CARBON	200 OHM 1/5 W
R436	CRD20TJ201T	RES , CARBON	200 OHM 1/5 W
R437	CRD20TJ153T	RES , CARBON	15K OHM 1/5W J
R438	CRD20TJ153T	RES , CARBON	15K OHM 1/5W J
R439	CRD20TJ153T	RES , CARBON	15K OHM 1/5W J
R440	CRD20TJ153T	RES , CARBON	15K OHM 1/5W J
R441	CRD20TJ201T	RES , CARBON	200 OHM 1/5 W
R442	CRD20TJ201T	RES , CARBON	200 OHM 1/5 W
R443	CRD20TJ201T	RES , CARBON	200 OHM 1/5 W
R444	CRD20TJ201T	RES , CARBON	200 OHM 1/5 W
R445	CRD50FJ100T	RES , CARBON	10 ohm 1/2W 5%
R446	CRD50FJ100T	RES , CARBON	10 ohm 1/2W 5%
R447	CRD50FJ100T	RES , CARBON	10 ohm 1/2W 5%
R448	CRD50FJ100T	RES , CARBON	10 ohm 1/2W 5%
R450	CRD20TJ472T	RES , CARBON	4.7K OHM 1/5W J
R451	CRD20TJ473T	RES , CARBON	47K OHM 1/5W J
R452	CRD20TJ473T	RES , CARBON	47K OHM 1/5W J
R453	CRD20TJ473T	RES , CARBON	47K OHM 1/5W J
R454	CRD20TJ473T	RES , CARBON	47K OHM 1/5W J
R455	CRD20TJ473T	RES , CARBON	47K OHM 1/5W J
R456	CRD20TJ473T	RES , CARBON	47K OHM 1/5W J
R457	CRD20TJ101T	RES , CARBON	100 OHM 1/5W J
R458	CRD20TJ101T	RES , CARBON	100 OHM 1/5W J
R459	CRD20TJ101T	RES , CARBON	100 OHM 1/5W J
R460	CRD20TJ101T	RES , CARBON	100 OHM 1/5W J
R461	CRD20TJ150T	RES , CARBON	15 OHM 1/5W J
R462	CRD20TJ150T	RES , CARBON	15 OHM 1/5W J
R463	CRD20TJ150T	RES , CARBON	15 OHM 1/5W J
R464	CRD20TJ150T	RES , CARBON	15 OHM 1/5W J

Ref. Designator	Part Number	Description	Qty
MAIN HEAT SINK ASS'Y		CUP12037Y	
R465	CRD20TJ2R2T	RES , CARBON	2.2 OHM 1/5W J
R466	CRD20TJ2R2T	RES , CARBON	2.2 OHM 1/5W J
R467	CRD20TJ2R2T	RES , CARBON	2.2 OHM 1/5W J
R468	CRD20TJ2R2T	RES , CARBON	2.2 OHM 1/5W J
R469	CRD20TJ820T	RES , CARBON	82 OHM 1/5W J
R470	CRD20TJ820T	RES , CARBON	82 OHM 1/5W J
R473	CRD20TJ100T	RES , CARBON	10 OHM 1/5W J
R474	CRD20TJ100T	RES , CARBON	10 OHM 1/5W J
R479	CRD20TJ104T	RES , CARBON	100K OHM 1/5W J
R480	CRD20TJ104T	RES , CARBON	100K OHM 1/5W J
R481	CRD20TJ152T	RES , CARBON	1.5K OHM 1/5W J
R482	CRD20TJ153T	RES , CARBON	15K OHM 1/5W J
R483	CRD20TJ152T	RES , CARBON	1.5K OHM 1/5W J
R484	CRD20TJ393T	RES , CARBON	39K ohm 1/4W 5%
R485	CRD20TJ103T	RES , CARBON	10K OHM 1/5W J
R486	CRD20TJ223T	RES , CARBON	22K OHM 1/5W J
R487	CRD20TJ393T	RES , CARBON	39K ohm 1/4W 5%
R488	CRD20TJ152T	RES , CARBON	1.5K OHM 1/5W J
R489	CRD20TJ153T	RES , CARBON	15K OHM 1/5W J
R490	CRD20TJ152T	RES , CARBON	1.5K OHM 1/5W J
R491	CRD20TJ393T	RES , CARBON	39K ohm 1/4W 5%
R492	CRD20TJ223T	RES , CARBON	22K OHM 1/5W J
R493	CRD20TJ822T	RES , CARBON	8.2K OHM 1/5W J
R495	CRD20TJ471T	RES , CARBON	470 OHM 1/5W J
R497	CRD20TJ271T	RES , CARBON	270 OHM 1/5W J
R498	CRD20TJ273T	RES , CARBON	27K OHM 1/5W J
R499	CRD20TJ471T	RES , CARBON	470 OHM 1/5W J
R130	CRG2SANJ2R2H	RES , METAL OXIDE(2.2 OHM 5% 2.0W)	2R2 OHM +5% 2.0W
R131	CRG2SANJ2R2H	RES , METAL OXIDE(2.2 OHM 5% 2.0W)	2R2 OHM +5% 2.0W
R144	CRG2SANJ3R3H	RES , METAL OXIDE(3.3 OHM 5% 2.0W)	3R3 OHM +5% 2.0W
R145	CRG2SANJ4R7H	RES , METAL OXIDE(4.7 OHM 5% 2.0W)	4R7 OHM +5% 2.0W
R146	CRG2SANJ3R3H	RES , METAL OXIDE(3.3 OHM 5% 2.0W)	3R3 OHM +5% 2.0W
R147	CRG2SANJ3R3H	RES , METAL OXIDE(3.3 OHM 5% 2.0W)	3R3 OHM +5% 2.0W
R149	CRG2SANJ2R2H	RES , METAL OXIDE(2.2 OHM 5% 2.0W)	2R2 OHM +5% 2.0W
R193	CRG2SANJ121RT	RES , METAL OXIDE FILM(2W, 120)	(2W, 120)
R199	CRG2SANJ121RT	RES , METAL OXIDE FILM(2W, 120)	(2W, 120)
R378	CRF5EKR22HX2	RES , CEMENT	0.22OHM(*2), 5W
R379	CRF5EKR22HX2	RES , CEMENT	0.22OHM(*2), 5W
R392	CRG1ANJ100H	RES , METAL OXIDE FILM	10 OHM 1W J
R393	CRG1ANJ100H	RES , METAL OXIDE FILM	10 OHM 1W J
R471	CRF5EKR22HX2	RES , CEMENT	0.22OHM(*2), 5W
R472	CRF5EKR22HX2	RES , CEMENT	0.22OHM(*2), 5W
R475	CRG1ANJ100H	RES , METAL OXIDE FILM	10 OHM 1W J
R476	CRG1ANJ100H	RES , METAL OXIDE FILM	10 OHM 1W J
VR101	CVN1RA221B02T	RES , SEMI FIXED (220, B CURVE)	KVSF637AVC
VR102	CVN1RA221B02T	RES , SEMI FIXED (220, B CURVE)	KVSF637AVC
VR103	CVN1RA221B02T	RES , SEMI FIXED (220, B CURVE)	KVSF637AVC
VR104	CVN1RA221B02T	RES , SEMI FIXED (220, B CURVE)	KVSF637AVC
<i>Miscellaneous</i>			
	CHD1A012R	SCREW , SPECIAL	19
	CMY1A291	HEAT SINK , MAIN AVR7550HD	1
	CHD1A012R	SCREW , SPECIAL	7
	CHD5A012JR	SCREW	1
	CMD1A657	BRACKET , POSISTOR AVR7550HD	1
	CMYAVR755HS1A295ZA	T.R HEAT SINK ASS'Y (CMY1A295)	1
	CHD1A012R	SCREW , SPECIAL	1
	CHD6A012JR	SCREW	4
	CMY1A295	HEAT SINK , REG. TR AVR7550HD	1
	CNE1A012	NUT , M3	4
	CTB3+8JFZR	SCREW	2
	CNW4A028	WASHER , FIBRE(0.5)	5
	CTB3+8JFZR	SCREW	1
	CTW3+8JFZR	SCREW	5
F101	KBA2D2000A2EYT	FUSE (382/TR5SERIES 2A 250V 8.5mm TL)	1
F102	KBA2D2000A2EYT	FUSE (382/TR5SERIES 2A 250V 8.5mm TL)	1
F103	KBA2D2000A2EYT	FUSE (382/TR5SERIES 2A 250V 8.5mm TL)	1
F104	KBA2D2000A2EYT	FUSE (382/TR5SERIES 2A 250V 8.5mm TL)	1
G102	HJT1A025	PLATE , EARTH	MET37-0002
G103	HJT1A025	PLATE , EARTH	MET37-0002

Ref. Designator	Part Number	Description	Qty
MAIN HEAT SINK ASS'Y		CUP12037Y	
JA101	CJJ4P055Z	JACK 4P WH/BL/RD/GY	RCA-401DAG-16 WH/BL/RD/GY
JA102	CJJ4P063Z	JACK , RCA (4P, 401DAG, GN BN PP TA, AU PL)	RCA-401DAG-18 (RCA 2x2)
JA103	CJJ9L004Z	JACK , RJ-45	GDL1-8P8C 8T BK
JA104	CJJ5Q017Z	TERMINAL , SPEAKER (8P, GY/BL/RD/WH, SCREW , AU)	SH081Q367G, DONGBO
L301	CLEY0R5KAK	COIL , SPEAKER	0.5UH K
L302	CLEY0R5KAK	COIL , SPEAKER	0.5UH K
L401	CLEY0R5KAK	COIL , SPEAKER	0.5UH K
L402	CLEY0R5KAK	COIL , SPEAKER	0.5UH K
N102	CWBAVR755N102	3P WIRE ASS'Y(400MM, 3.96MM)	
N106	CJP04GB99ZM	WAFER	35237-0410 2.0mm 4P WHT
N107	CJP04GB99ZM	WAFER	35237-0410 2.0mm 4P WHT
N108	CJP04GB99ZM	WAFER	35237-0410 2.0mm 4P WHT
N109	CJP04GB99ZM	WAFER	35237-0410 2.0mm 4P WHT
N110	CWB1E007180BM	7P WIRE ASS'Y(180MM, 2.5MM)	
N111	CJP07GB99ZY	HOUSING	35237-0710 2.0mm 7P WHT
N114	CWB1B005200GN	5P WIRE ASS'Y(200MM, 2.0MM)	
N131	CWB1C005350GN	5P WIRE ASS'Y(350MM, 2.0MM)	
P102	CJP07GA98ZY	WAFER	35336-0710 2.0mm 7P WHT
P103	CJP10GA98ZY	WAFER	35336-1010 2.0mm 10P WHT
P104	CJP05GA01ZY	WAFER(YMW025-05R)	5267-05A 2.5mm 5P WHT
P105	CJP07GA47ZW	WAFER(7P, ST 2MM)	GIL-S-7P-S2T2-EF 7P
P106	CJP02GA01ZY	WAFER , STRAIGHT, 2PIN	5267-02A 2.5mm 2P WHT
P107	CJP07GA98ZY	WAFER	35336-0710 2.0mm 7P WHT
P108	CJP16GA98ZM	WAFER(16P, ST 2MM)	35336-1610 2.0mm 16P WHT
P110	CJP03GA90ZY	WAFER	35313-0310 3.96mm 3P
P111	CJP02GA01ZY	WAFER , STRAIGHT, 2PIN	5267-02A 2.5mm 2P WHT
P112	CJP02GA01ZY	WAFER , STRAIGHT, 2PIN	5267-02A 2.5mm 2P WHT
P113	CJP02GA01ZY	WAFER , STRAIGHT, 2PIN	5267-02A 2.5mm 2P WHT
P114	CJP02GA01ZY	WAFER , STRAIGHT, 2PIN	5267-02A 2.5mm 2P WHT
P115	CJP04GA98ZM	WAFER	35336-0410 2.0mm 4P WHT
P116	CJP04GA98ZM	WAFER	35336-0410 2.0mm 4P WHT
P117	CJP04GA98ZM	WAFER	35336-0410 2.0mm 4P WHT
P118	CJP04GA98ZM	WAFER	35336-0410 2.0mm 4P WHT
SURROUND HEATSINK/PCB ASS'Y		CUP12044Z	
<i>Capacitors</i>			
C503	CCEA1HH100T	CAP , ELECT	10UF 50V
C504	CCBS1H271KBT	CAP , CERAMIC(270PF/50V)	CH UP025 B271K-A-B Z
C505	CCEA1EH101T	CAP , ELECT	100UF 25V
C506	CCBS1H271KBT	CAP , CERAMIC(270PF/50V)	CH UP025 B271K-A-B Z
C507	CCCT1H030CC	CAP , CERAMIC	3PF 50V C
C508	CCEA1AH221T	CAP , ELECT	220UF 10V
C509	CCKT1H181KB	CAP , CERAMIC	180PF 50V K
C510	CCME2A683JXT	CAP , METALIZED FILM (0.068UF/100V J)	(0.068UF/100V J)
C511	CCEA2AH100TS	CAP , ELECT(KRM, 100V/10UF, 6.3x11)	KRM, 100V/10UF, 6.3X11
C512	CCEA2AH100TS	CAP , ELECT(KRM, 100V/10UF, 6.3x11)	KRM, 100V/10UF, 6.3X11
C513	CCME2A104JXT	CAP , METALLIZED FILM	0.1uF, HMFS-5, 100V, ±5%
C514	CCME2A104JXT	CAP , METALLIZED FILM	0.1uF, HMFS-5, 100V, ±5%
C515	CCKT1H332KB	CAP , CERAMIC	3300PF 50V K
C516	CCFT1H103ZF	CAP , CERAMIC	0.01UF 50V Z
C603	CCEA1HH100T	CAP , ELECT	10UF 50V
C604	CCBS1H271KBT	CAP , CERAMIC(270PF/50V)	CH UP025 B271K-A-B Z
C605	CCEA1EH101T	CAP , ELECT	100UF 25V
C606	CCBS1H271KBT	CAP , CERAMIC(270PF/50V)	CH UP025 B271K-A-B Z
C607	CCCT1H030CC	CAP , CERAMIC	3PF 50V C
C608	CCEA1AH221T	CAP , ELECT	220UF 10V
C609	CCKT1H181KB	CAP , CERAMIC	180PF 50V K
C610	CCME2A683JXT	CAP , METALIZED FILM (0.068UF/100V J)	(0.068UF/100V J)
C611	CCEA2AH100TS	CAP , ELECT(KRM, 100V/10UF, 6.3x11)	KRM, 100V/10UF, 6.3X11
C612	CCEA2AH100TS	CAP , ELECT(KRM, 100V/10UF, 6.3x11)	KRM, 100V/10UF, 6.3X11
C613	CCME2A104JXT	CAP , METALLIZED FILM	0.1uF, HMFS-5, 100V, ±5%
C614	CCME2A104JXT	CAP , METALLIZED FILM	0.1uF, HMFS-5, 100V, ±5%
C615	CCKT1H332KB	CAP , CERAMIC	3300PF 50V K
C616	CCFT1H103ZF	CAP , CERAMIC	0.01UF 50V Z
C703	CCEA1HH100T	CAP , ELECT	10UF 50V
C704	CCBS1H271KBT	CAP , CERAMIC(270PF/50V)	CH UP025 B271K-A-B Z
C705	CCEA1EH101T	CAP , ELECT	100UF 25V
C706	CCBS1H271KBT	CAP , CERAMIC(270PF/50V)	CH UP025 B271K-A-B Z
C707	CCCT1H030CC	CAP , CERAMIC	3PF 50V C

Ref. Designator	Part Number	Description		Qty
SURROUND HEATSINK/PCB ASS'Y		CUP12044Z		
C708	CCEA1AH221T	CAP , ELECT	220UF 10V	1
C709	CCKT1H181KB	CAP , CERAMIC	180PF 50V K	1
C710	CCME2A683JXT	CAP , METALLIZED FILM (0.068UF/100V J)	(0.068UF/100V J)	1
C711	CCEA2AH100TS	CAP , ELECT(KRM, 100V/10UF, 6.3x11)	KRM, 100V/10UF, 6.3X11	1
C712	CCEA2AH100TS	CAP , ELECT(KRM, 100V/10UF, 6.3x11)	KRM, 100V/10UF, 6.3X11	1
C713	CCME2A104JXT	CAP , METALLIZED FILM	0.1uF, HMFS-5, 100V, ±5%	1
C714	CCME2A104JXT	CAP , METALLIZED FILM	0.1uF, HMFS-5, 100V, ±5%	1
C715	CCKT1H332KB	CAP , CERAMIC	3300PF 50V K	1
C716	CCFT1H103ZF	CAP , CERAMIC	0.01UF 50V Z	1
C807	CCFT1H104ZF	CAP , SEMICONDUCTOR	0.1UF 50V Z	1
C808	CCFT1H104ZF	CAP , SEMICONDUCTOR	0.1UF 50V Z	1
C809	CCEA1HH100T	CAP , ELECT	10UF 50V	1
C810	CCEA1HH100T	CAP , ELECT	10UF 50V	1
C811	CCFT1H104ZF	CAP , SEMICONDUCTOR	0.1UF 50V Z	1
C812	CCEA1HH100T	CAP , ELECT	10UF 50V	1
C901	CCEA1HH100T	CAP , ELECT	10UF 50V	1
C501	CCEA1JH471E	CAP , ELECT	470uF 63V +20% 85C	1
C502	CCEA1JH471E	CAP , ELECT	470uF 63V +20% 85C	1
C601	CCEA1JH471E	CAP , ELECT	470uF 63V +20% 85C	1
C602	CCEA1JH471E	CAP , ELECT	470uF 63V +20% 85C	1
C701	CCEA1JH471E	CAP , ELECT	470uF 63V +20% 85C	1
C702	CCEA1JH471E	CAP , ELECT	470uF 63V +20% 85C	1
C800	CCEA1CH682E	CAP , ELECT	6800uF 16V M 16x25 85C 120Hz	1
C804	CCEA1EH222E	CAP , ELECT	2200UF 25V	1
C806	CCEA1CH682E	CAP , ELECT	6800uF 16V M 16x25 85C 120Hz	1
C813	CCEA1CH682E	CAP , ELECT	6800uF 16V M 16x25 85C 120Hz	1
C814	CCEA1CH682E	CAP , ELECT	6800uF 16V M 16x25 85C 120Hz	1
C815	CCEA1EH222E	CAP , ELECT	2200UF 25V	1
C816	CCFT1H104ZF	CAP , SEMICONDUCTOR	0.1UF 50V Z	1
C817	CCFT1H104ZF	CAP , SEMICONDUCTOR	0.1UF 50V Z	1
<i>Semiconductors</i>				
D501	HVD1N4148T	DIODE	1N4148	1
D502	HVD1N4148T	DIODE	1N4148	1
D503	HVD1N4148T	DIODE	1N4148	1
D504	HVD1N4148T	DIODE	1N4148	1
D601	HVD1N4148T	DIODE	1N4148	1
D602	HVD1N4148T	DIODE	1N4148	1
D603	HVD1N4148T	DIODE	1N4148	1
D604	HVD1N4148T	DIODE	1N4148	1
D701	HVD1N4148T	DIODE	1N4148	1
D702	HVD1N4148T	DIODE	1N4148	1
D703	HVD1N4148T	DIODE	1N4148	1
D704	HVD1N4148T	DIODE	1N4148	1
D802	HVD1N4148T	DIODE	1N4148	1
D803	HVD1N4148T	DIODE	1N4148	1
D901	HVD1N4148T	DIODE	1N4148	1
IC801	CVIKIA578R033PI	I.C , REGULATOR 5A (TO-220IS-4)	KIA578R033PI	1
IC802	HVIKIA278R05PI	REGULATOR (5V OUTPUT LOW DROP)	KIA278R05PI	1
IC803	CVIKIA7905PI	I.C , REGULATOR(-5V)	KIA7905PI-U/PF	1
Q514	HVTKTC3114A	TRANSISTOR , BIAS NPN	KTC3114A	1
Q516	HVT2SA1859A	TRANSISTOR , DRIVER PNP	2SA1859A P -2.0A	1
Q517	HVT2SC4883A	TRANSISTOR , DRIVER NPN	2SC4883A N 2.0A	1
Q518	CVT2SC5358R	TRANSISTOR , POWER(NPN 230V,15A, 80W)	2SC535R-R , TOSHIBA	1
Q519	CVT2SA1986R	TRANSISTOR , POWER(PNP 230V,15A, 80W)	2SC1986-R , TOSHIBA	1
Q614	HVTKTC3114A	TRANSISTOR , BIAS NPN	KTC3114A	1
Q616	HVT2SA1859A	TRANSISTOR , DRIVER PNP	2SA1859A P -2.0A	1
Q617	HVT2SC4883A	TRANSISTOR , DRIVER NPN	2SC4883A N 2.0A	1
Q618	CVT2SC5358R	TRANSISTOR , POWER(NPN 230V,15A, 80W)	2SC535R-R , TOSHIBA	1
Q619	CVT2SA1986R	TRANSISTOR , POWER(PNP 230V,15A, 80W)	2SC1986-R , TOSHIBA	1
Q714	HVTKTC3114A	TRANSISTOR , BIAS NPN	KTC3114A	1
Q716	HVT2SA1859A	TRANSISTOR , DRIVER PNP	2SA1859A P -2.0A	1
Q717	HVT2SC4883A	TRANSISTOR , DRIVER NPN	2SC4883A N 2.0A	1
Q718	CVT2SC5358R	TRANSISTOR , POWER(NPN 230V,15A, 80W)	2SC535R-R , TOSHIBA	1
Q719	CVT2SA1986R	TRANSISTOR , POWER(PNP 230V,15A, 80W)	2SC1986-R , TOSHIBA	1
Q501	HVTKTC3200GRT	TRANSISTOR NPN	KTC3200GR	1
Q502	HVTKTC3200GRT	TRANSISTOR NPN	KTC3200GR	1
Q503	HVTKTC3200GRT	TRANSISTOR NPN	KTC3200GR	1
Q504	HVTKTC3198YT	TRANSISTOR NPN	KTC3198Y	1
Q505	CVT2SA1145YFT	TRANSISTOR , PNP HFE:120-240 TO-92L	2SA1145-Y(TE6,F	1

Ref. Designator	Part Number	Description		Qty
SURROUND HEATSINK/PCB ASS'Y		CUP12044Z		
Q506	HVTKTA1268GRT	TRANSISTOR PNP	KTA1268GR	1
Q507	HVTKTC3200GRT	TRANSISTOR NPN	KTC3200GR	1
Q508	HVTKTA1024YT	TRANSISTOR PNP	KTA1024 Y P 50MIOA -150V	1
Q509	HVTKTC3206YAT	TRANSISTOR HIGH VOLTAGE NPN	KTC3206-Y-AT/P	1
Q511	HVTKTA1024YT	TRANSISTOR PNP	KTA1024-Y-AT/P	1
Q512	HVTKTC3206YAT	TRANSISTOR HIGH VOLTAGE NPN	KTC3206-Y-AT/P	1
Q520	HVTKTC3200GRT	TRANSISTOR NPN	KTC3200GR	1
Q601	HVTKTC3200GRT	TRANSISTOR NPN	KTC3200GR	1
Q602	HVTKTC3200GRT	TRANSISTOR NPN	KTC3200GR	1
Q603	HVTKTC3200GRT	TRANSISTOR NPN	KTC3200GR	1
Q604	HVTKTC3198YT	TRANSISTOR NPN	KTC3198Y	1
Q605	CVT2SA1145YFT	TRANSISTOR , PNP HFE:120~240 TO-92L	2SA1145-Y(TE6,F	1
Q606	HVTKTA1268GRT	TRANSISTOR PNP	KTA1268GR	1
Q607	HVTKTC3200GRT	TRANSISTOR NPN	KTC3200GR	1
Q608	HVTKTA1024YT	TRANSISTOR PNP	KTA1024-Y-AT/P	1
Q609	HVTKTC3206YAT	TRANSISTOR HIGH VOLTAGE NPN	KTC3206-Y-AT/P	1
Q611	HVTKTA1024YT	TRANSISTOR PNP	KTA1024-Y-AT/P	1
Q612	HVTKTC3206YAT	TRANSISTOR HIGH VOLTAGE NPN	KTC3206-Y-AT/P	1
Q620	HVTKTC3200GRT	TRANSISTOR NPN	KTC3200GR	1
Q701	HVTKTC3200GRT	TRANSISTOR NPN	KTC3200GR	1
Q702	HVTKTC3200GRT	TRANSISTOR NPN	KTC3200GR	1
Q703	HVTKTC3200GRT	TRANSISTOR NPN	KTC3200GR	1
Q704	HVTKTC3198YT	TRANSISTOR NPN	KTC3198Y	1
Q705	CVT2SA1145YFT	TRANSISTOR , PNP HFE:120~240 TO-92L	2SA1145-Y(TE6,F	1
Q706	HVTKTA1268GRT	TRANSISTOR PNP	KTA1268GR	1
Q707	HVTKTC3200GRT	TRANSISTOR NPN	KTC3200GR	1
Q708	HVTKTA1024YT	TRANSISTOR PNP	KTA1024-Y-AT/P	1
Q709	HVTKTC3206YAT	TRANSISTOR HIGH VOLTAGE NPN	KTC3206-Y-AT/P	1
Q711	HVTKTA1024YT	TRANSISTOR PNP	KTA1024-Y-AT/P	1
Q712	HVTKTC3206YAT	TRANSISTOR HIGH VOLTAGE NPN	KTC3206-Y-AT/P	1
Q720	HVTKTC3200GRT	TRANSISTOR NPN	KTC3200GR	1
Q901	HVTKTA1268GRT	TRANSISTOR PNP	KTA1268GR	1
Q513	HVTKTC3423Y	TRANSISTOR , PRE DRIVE	KTC3423Y	1
Q515	HVTKTA1360Y	TRANSISTOR , PRE DRIVE	KTA1360Y	1
Q613	HVTKTC3423Y	TRANSISTOR , PRE DRIVE	KTC3423Y	1
Q615	HVTKTA1360Y	TRANSISTOR , PRE DRIVE	KTA1360Y	1
Q713	HVTKTC3423Y	TRANSISTOR , PRE DRIVE	KTC3423Y	1
Q715	HVTKTA1360Y	TRANSISTOR , PRE DRIVE	KTA1360Y	1
<i>Resistors</i>				
R501	CRD20TJ331T	RES , CARBON	330 OHM 1/5W J	1
R502	CRD20TJ333T	RES , CARBON	33K OHM 1/5W J	1
R504	CRD20TJ433T	RES , CARBON	43K OHM 1/5W J	1
R505	CRD20TJ221T	RES , CARBON	220 OHM 1/5W J	1
R506	CRD20TJ221T	RES , CARBON	220 OHM 1/5W J	1
R507	CRD20TJ221T	RES , CARBON	220 OHM 1/5W J	1
R508	CRD20TJ471T	RES , CARBON	470 OHM 1/5W J	1
R509	CRD20TJ162T	RES , CARBON	1K6 ohm 1/4W 5%	1
R510	CRD20TJ162T	RES , CARBON	1K6 ohm 1/4W 5%	1
R511	CRD20TJ561T	RES , CARBON	560 OHM 1/5W J	1
R512	CRD20TF3302T	RES , CARBON	33K0ohm +1% 1/4W SMALL TYPE	1
R513	CRD20TF1401T	RES , CARBON	1.4K OHM 1% 1/6W	1
R514	CRD20TJ561T	RES , CARBON	560 OHM 1/5W J	1
R515	CRD20TJ561T	RES , CARBON	560 OHM 1/5W J	1
R516	CRD20TJ561T	RES , CARBON	560 OHM 1/5W J	1
R517	CRD20TJ561T	RES , CARBON	560 OHM 1/5W J	1
R518	CRD20TJ561T	RES , CARBON	560 OHM 1/5W J	1
R519	CRD20TJ201T	RES , CARBON	200 OHM 1/5 W	1
R520	CRD20TJ153T	RES , CARBON	15K OHM 1/5W J	1
R521	CRD20TJ153T	RES , CARBON	15K OHM 1/5W J	1
R522	CRD20TJ201T	RES , CARBON	200 OHM 1/5 W	1
R523	CRD20TJ201T	RES , CARBON	200 OHM 1/5 W	1
R524	CRD20TJ201T	RES , CARBON	200 OHM 1/5 W	1
R525	CRD50FJ100T	RES , CARBON	10 ohm 1/2W 5%	1
R526	CRD20TJ101T	RES , CARBON	100 OHM 1/5W J	1
R527	CRD20TJ2R2T	RES , CARBON	2.2 OHM 1/5W J	1
R528	CRD20TJ150T	RES , CARBON	15 OHM 1/5W J	1
R529	CRD20TF2801T	RES , CARBON	2K8 ohm 1/4W 5%	1
R530	CRD20TJ821T	RES , CARBON	820 OHM 1/5W J	1
R533	CRD50FJ100T	RES , CARBON	10 ohm 1/2W 5%	1

Ref. Designator	Part Number	Description	Qty
SURROUND HEATSINK/PCB ASS'Y		CUP12044Z	
R534	CRD20TJ820T	RES , CARBON	82 OHM 1/5W J
R535	CRD20TJ150T	RES , CARBON	15 OHM 1/5W J
R536	CRD20TJ101T	RES , CARBON	100 OHM 1/5W J
R537	CRD20TJ2R2T	RES , CARBON	2.2 OHM 1/5W J
R539	CRD20TJ152T	RES , CARBON	1.5K OHM 1/5W J
R540	CRD20TJ153T	RES , CARBON	15K OHM 1/5W J
R541	CRD20TJ152T	RES , CARBON	1.5K OHM 1/5W J
R542	CRD20TJ393T	RES , CARBON	39K ohm 1/4W 5%
R543	CRD20TJ100T	RES , CARBON	10 OHM 1/5W J
R544	CRD20TJ223T	RES , CARBON	22K OHM 1/5W J
R546	CRD20TJ104T	RES , CARBON	100K OHM 1/5W J
R599	CRD20TJ100T	RES , CARBON	10 OHM 1/5W J
R601	CRD20TJ331T	RES , CARBON	330 OHM 1/5W J
R602	CRD20TJ333T	RES , CARBON	33K OHM 1/5W J
R604	CRD20TJ433T	RES , CARBON	43K OHM 1/5W J
R605	CRD20TJ221T	RES , CARBON	220 OHM 1/5W J
R606	CRD20TJ221T	RES , CARBON	220 OHM 1/5W J
R607	CRD20TJ221T	RES , CARBON	220 OHM 1/5W J
R608	CRD20TJ471T	RES , CARBON	470 OHM 1/5W J
R609	CRD20TJ162T	RES , CARBON	1K6 ohm 1/4W 5%
R610	CRD20TJ162T	RES , CARBON	1K6 ohm 1/4W 5%
R611	CRD20TJ561T	RES , CARBON	560 OHM 1/5W J
R612	CRD20TF3302T	RES , CARBON	33K0ohm +1% 1/4W SMALL TYPE
R613	CRD20TF1401T	RES , CARBON	1.4K OHM 1% 1/6W
R614	CRD20TJ561T	RES , CARBON	560 OHM 1/5W J
R615	CRD20TJ561T	RES , CARBON	560 OHM 1/5W J
R616	CRD20TJ561T	RES , CARBON	560 OHM 1/5W J
R617	CRD20TJ561T	RES , CARBON	560 OHM 1/5W J
R618	CRD20TJ561T	RES , CARBON	560 OHM 1/5W J
R619	CRD20TJ201T	RES , CARBON	200 OHM 1/5 W
R620	CRD20TJ153T	RES , CARBON	15K OHM 1/5W J
R621	CRD20TJ153T	RES , CARBON	15K OHM 1/5W J
R622	CRD20TJ201T	RES , CARBON	200 OHM 1/5 W
R623	CRD20TJ201T	RES , CARBON	200 OHM 1/5 W
R624	CRD20TJ201T	RES , CARBON	200 OHM 1/5 W
R625	CRD50FJ100T	RES , CARBON	10 ohm 1/2W 5%
R626	CRD20TJ101T	RES , CARBON	100 OHM 1/5W J
R627	CRD20TJ2R2T	RES , CARBON	2.2 OHM 1/5W J
R628	CRD20TJ150T	RES , CARBON	15 OHM 1/5W J
R629	CRD20TF2801T	RES , CARBON	2K8 ohm 1/4W 5%
R630	CRD20TJ821T	RES , CARBON	820 OHM 1/5W J
R633	CRD50FJ100T	RES , CARBON	10 ohm 1/2W 5%
R634	CRD20TJ820T	RES , CARBON	82 OHM 1/5W J
R635	CRD20TJ150T	RES , CARBON	15 OHM 1/5W J
R636	CRD20TJ101T	RES , CARBON	100 OHM 1/5W J
R637	CRD20TJ2R2T	RES , CARBON	2.2 OHM 1/5W J
R639	CRD20TJ152T	RES , CARBON	1.5K OHM 1/5W J
R640	CRD20TJ153T	RES , CARBON	15K OHM 1/5W J
R641	CRD20TJ152T	RES , CARBON	1.5K OHM 1/5W J
R642	CRD20TJ393T	RES , CARBON	39K ohm 1/4W 5%
R643	CRD20TJ100T	RES , CARBON	10 OHM 1/5W J
R644	CRD20TJ223T	RES , CARBON	22K OHM 1/5W J
R646	CRD20TJ104T	RES , CARBON	100K OHM 1/5W J
R699	CRD20TJ100T	RES , CARBON	10 OHM 1/5W J
R701	CRD20TJ331T	RES , CARBON	330 OHM 1/5W J
R702	CRD20TJ333T	RES , CARBON	33K OHM 1/5W J
R704	CRD20TJ433T	RES , CARBON	43K OHM 1/5W J
R705	CRD20TJ221T	RES , CARBON	220 OHM 1/5W J
R706	CRD20TJ221T	RES , CARBON	220 OHM 1/5W J
R707	CRD20TJ221T	RES , CARBON	220 OHM 1/5W J
R708	CRD20TJ471T	RES , CARBON	470 OHM 1/5W J
R709	CRD20TJ162T	RES , CARBON	1K6 ohm 1/4W 5%
R710	CRD20TJ162T	RES , CARBON	1K6 ohm 1/4W 5%
R711	CRD20TJ561T	RES , CARBON	560 OHM 1/5W J
R712	CRD20TF3302T	RES , CARBON	33K0ohm +1% 1/4W SMALL TYPE
R713	CRD20TF1401T	RES , CARBON	1.4K OHM 1% 1/6W
R714	CRD20TJ561T	RES , CARBON	560 OHM 1/5W J
R715	CRD20TJ561T	RES , CARBON	560 OHM 1/5W J
R716	CRD20TJ561T	RES , CARBON	560 OHM 1/5W J
R717	CRD20TJ561T	RES , CARBON	560 OHM 1/5W J
R718	CRD20TJ561T	RES , CARBON	560 OHM 1/5W J

Ref. Designator	Part Number	Description	Qty
SURROUND HEATSINK/PCB ASS'Y		CUP12044Z	
R719	CRD20TJ201T	RES , CARBON	200 OHM 1/5 W
R720	CRD20TJ153T	RES , CARBON	15K OHM 1/5W J
R721	CRD20TJ153T	RES , CARBON	15K OHM 1/5W J
R722	CRD20TJ201T	RES , CARBON	200 OHM 1/5 W
R723	CRD20TJ201T	RES , CARBON	200 OHM 1/5 W
R724	CRD20TJ201T	RES , CARBON	200 OHM 1/5 W
R725	CRD50FJ100T	RES , CARBON	10 ohm 1/2W 5%
R726	CRD20TJ101T	RES , CARBON	100 OHM 1/5W J
R727	CRD20TJ2R2T	RES , CARBON	2.2 OHM 1/5W J
R728	CRD20TJ150T	RES , CARBON	15 OHM 1/5W J
R729	CRD20TF2801T	RES , CARBON	2K8 ohm 1/4W 5%
R730	CRD20TJ821T	RES , CARBON	820 OHM 1/5W J
R733	CRD50FJ100T	RES , CARBON	10 ohm 1/2W 5%
R734	CRD20TJ820T	RES , CARBON	82 OHM 1/5W J
R735	CRD20TJ150T	RES , CARBON	15 OHM 1/5W J
R736	CRD20TJ101T	RES , CARBON	100 OHM 1/5W J
R737	CRD20TJ2R2T	RES , CARBON	2.2 OHM 1/5W J
R739	CRD20TJ152T	RES , CARBON	1.5K OHM 1/5W J
R740	CRD20TJ153T	RES , CARBON	15K OHM 1/5W J
R741	CRD20TJ152T	RES , CARBON	1.5K OHM 1/5W J
R742	CRD20TJ393T	RES , CARBON	39K ohm 1/4W 5%
R743	CRD20TJ100T	RES , CARBON	10 OHM 1/5W J
R744	CRD20TJ223T	RES , CARBON	22K OHM 1/5W J
R746	CRD20TJ104T	RES , CARBON	100K OHM 1/5W J
R799	CRD20TJ100T	RES , CARBON	10 OHM 1/5W J
R805	CRD20TJ103T	RES , CARBON	10K OHM 1/5W J
R806	CRD20TJ103T	RES , CARBON	10K OHM 1/5W J
R807	CRD20TJ471T	RES , CARBON	470 OHM 1/5W J
R808	CRD20TJ101T	RES , CARBON	100 OHM 1/5W J
R901	CRD20TJ103T	RES , CARBON	10K OHM 1/5W J
R902	CRD20TJ393T	RES , CARBON	39K ohm 1/4W 5%
R538	CRF5EKR22HX2	RES , CEMENT	0.22OHM(*2), 5W
R545	CRG1ANJ100H	RES , METAL OXIDE FILM	10 OHM 1W J
R638	CRF5EKR22HX2	RES , CEMENT	0.22OHM(*2), 5W
R645	CRG1ANJ100H	RES , METAL OXIDE FILM	10 OHM 1W J
R738	CRF5EKR22HX2	RES , CEMENT	0.22OHM(*2), 5W
R745	CRG1ANJ100H	RES , METAL OXIDE FILM	10 OHM 1W J
VR501	CVN3RE221B02	RES , SEMI FIXED METAL(220 OHM, B CURVE, 6.4X7.3)	EVMEGGA00BE2
VR601	CVN3RE221B02	RES , SEMI FIXED METAL(220 OHM, B CURVE, 6.4X7.3)	EVMEGGA00BE2
VR701	CVN3RE221B02	RES , SEMI FIXED METAL(220 OHM, B CURVE, 6.4X7.3)	EVMEGGA00BE2
<i>Miscellaneous</i>			
	CTB3+8JFZR	SCREW	1
	CTW3+8JR	SCREW	5
	CMYAVR755SA	SURROUND SUB HEAT SINK ASS'Y	1
	CHD1A012R	SCREW , SPECIAL	18
	CMD1A657	BRACKET , POSISTOR AVR755	1
	CMD1A660	BRACKET , HEAT SINK AVR755	5
	CMY1A292	HEAT SINK , SURR AMP AVR755	1
	CTB3+8JFZR	SCREW	5
G801	HJT1A025	PLATE , EARTH	MET37-0002
G900	HJT1A025	PLATE , EARTH	MET37-0002
G901	HJT1A025	PLATE , EARTH	MET37-0002
JA901	CJJ5R014Z	TERMINAL , SPEAKER (6P, GN/BN/TA, SCREW , AU)	SH061Q707G, DONGBO
L501	CLEY0R5KAK	COIL , SPEAKER	0.5UH K
L601	CLEY0R5KAK	COIL , SPEAKER	0.5UH K
L701	CLEY0R5KAK	COIL , SPEAKER	0.5UH K
N501	CWB1E007300BM	7P WIRE ASS'Y(300MM, 2.5MM)	
N502	CWBAVR755N502	6P WIRE ASS'Y(120MM, 3.96MM)	
N503	CJP03GA90ZY	WAFER	35313-0310 3.96mm 3P
N505	CWBAVR755N505	10P WIRE ASS'Y(250MM, 2.0MM)	
P501	CJP02GB03ZY	WAFER , 2P(2.5MM BOARD TYPE)	YEONHO YM025 SERIES
P506	CJP03GA47ZW	WAFER(3P, ST 2MM)	GIL-S-3P-S2T2-EF 3P
P601	CJP02GB03ZY	WAFER , 2P(2.5MM BOARD TYPE)	YEONHO YM025 SERIES
P701	CJP02GB03ZY	WAFER , 2P(2.5MM BOARD TYPE)	YEONHO YM025 SERIES
W900	CWBAVR755W900	2P WIRE ASS'Y(230MM, 3.96MM)	

Ref. Designator	Part Number	Description	Qty
DSP PCB ASS'Y		COP12038B	
<i>Capacitors</i>			
C4035	CCUS1H104KC	CAP , CHIP	0.1UF 50V K
C4041	CCUS1H104KC	CAP , CHIP	0.1UF 50V K
C4050	CCUS1H104KC	CAP , CHIP	0.1UF 50V K
C4051	CCUS1H104KC	CAP , CHIP	0.1UF 50V K
C4099	CCUS1H104KC	CAP , CHIP	0.1UF 50V K
C4192	CCSJB1A220B	CAP , CHIP TANTAL(B TYPE, 22uF/10V, ELNA)	22uF/10V
C4194	CCUS1H104KC	CAP , CHIP	0.1UF 50V K
C4195	CCUS1H101JA	CAP , CHIP	100PF 50V J
C4196	CCUS1H101JA	CAP , CHIP	100PF 50V J
C4197	CCUS1H101JA	CAP , CHIP	100PF 50V J
C4198	CCUS1H101JA	CAP , CHIP	100PF 50V J
C4199	CCUS1H101JA	CAP , CHIP	100PF 50V J
C4200	CCUS1H101JA	CAP , CHIP	100PF 50V J
C4201	CCUS1H101JA	CAP , CHIP	100PF 50V J
C4202	CCUS1H101JA	CAP , CHIP	100PF 50V J
C4203	CCUS1H104KC	CAP , CHIP	0.1UF 50V K
C4204	CCUS1H104KC	CAP , CHIP	0.1UF 50V K
C4205	CCUS1H104KC	CAP , CHIP	0.1UF 50V K
C4207	CCUS1H200JA	CAP , CHIP	20pF 50V CH J NP0 0603
C4209	CCUS1H220JA	CAP , CHIP	22PF 50V J
C4210	CCUS1H220JA	CAP , CHIP	22PF 50V J
C4211	CCUS1H220JA	CAP , CHIP	22PF 50V J
C4212	CCUS1H220JA	CAP , CHIP	22PF 50V J
C4213	CCUS1H104KC	CAP , CHIP	0.1UF 50V K
C4214	CCUS1H103KC	CAP , CHIP	0.01UF 50V K
C4215	CCUS1H104KC	CAP , CHIP	0.1UF 50V K
C4216	CCUS1H103KC	CAP , CHIP	0.01UF 50V K
C4217	CCUS1H103KC	CAP , CHIP	0.01UF 50V K
C4218	CCUS1H101JA	CAP , CHIP	100PF 50V J
C4219	CCUS1H101JA	CAP , CHIP	100PF 50V J
C4220	CCUS1H101JA	CAP , CHIP	100PF 50V J
C4221	CCUS1H101JA	CAP , CHIP	100PF 50V J
C4222	CCUS1H101JA	CAP , CHIP	100PF 50V J
C4223	CCUS1H101JA	CAP , CHIP	100PF 50V J
C4224	CCUS1H101JA	CAP , CHIP	100PF 50V J
C4225	CCUS1H101JA	CAP , CHIP	100PF 50V J
C4226	CCUS1H104KC	CAP , CHIP	0.1UF 50V K
C4227	CCUS1H104KC	CAP , CHIP	0.1UF 50V K
C4228	CCUS1H104KC	CAP , CHIP	0.1UF 50V K
C4229	CCUS1H104KC	CAP , CHIP	0.1UF 50V K
C4230	CCUS1H104KC	CAP , CHIP	0.1UF 50V K
C4233	CCUS1H104KC	CAP , CHIP	0.1UF 50V K
C4235	CCUS1H104KC	CAP , CHIP	0.1UF 50V K
C4237	CCUS1H104KC	CAP , CHIP	0.1UF 50V K
C4238	CCUS1H221JA	CAP , CHIP	220PF 50V J
C4239	CCUS1H104KC	CAP , CHIP	0.1UF 50V K
C4240	CCUS1H104KC	CAP , CHIP	0.1UF 50V K
C4242	CCUS1H104KC	CAP , CHIP	0.1UF 50V K
C4243	CCUS1H104KC	CAP , CHIP	0.1UF 50V K
C4244	CCUS1H104KC	CAP , CHIP	0.1UF 50V K
C4245	CCUS1H104KC	CAP , CHIP	0.1UF 50V K
C4246	CCUS1H104KC	CAP , CHIP	0.1UF 50V K
C4247	CCUS1H104KC	CAP , CHIP	0.1UF 50V K
C4249	CCUS1H101JA	CAP , CHIP	100PF 50V J
C4250	CCUS1H101JA	CAP , CHIP	100PF 50V J
C4251	CCUS1H101JA	CAP , CHIP	100PF 50V J
C4252	CCUS1H101JA	CAP , CHIP	100PF 50V J
C4253	CCUS1H101JA	CAP , CHIP	100PF 50V J
C4254	CCUS1H101JA	CAP , CHIP	100PF 50V J
C4255	CCUS1H101JA	CAP , CHIP	100PF 50V J
C4256	CCUS1H101JA	CAP , CHIP	100PF 50V J
C4257	CCUS1H104KC	CAP , CHIP	0.1UF 50V K
C4258	CCUS1H104KC	CAP , CHIP	0.1UF 50V K
C4261	CCUS1H104KC	CAP , CHIP	0.1UF 50V K
C4262	CCUS1H104KC	CAP , CHIP	0.1UF 50V K
C4263	CCUS1H104KC	CAP , CHIP	0.1UF 50V K
C4264	CCUS1H104KC	CAP , CHIP	0.1UF 50V K
C4265	CCUS1H104KC	CAP , CHIP	0.1UF 50V K
C4266	CCUS1H104KC	CAP , CHIP	0.1UF 50V K

Ref. Designator	Part Number	Description	Qty
DSP PCB ASS'Y		COP12038B	
C4267	CCUS1H104KC	CAP , CHIP	0.1UF 50V K
C4268	CCUS1H104KC	CAP , CHIP	0.1UF 50V K
C4270	CCUS1H101JA	CAP , CHIP	100PF 50V J
C4271	CCUS1H101JA	CAP , CHIP	100PF 50V J
C4272	CCUS1H101JA	CAP , CHIP	100PF 50V J
C4273	CCUS1H101JA	CAP , CHIP	100PF 50V J
C4274	CCUS1H101JA	CAP , CHIP	100PF 50V J
C4275	CCUS1H101JA	CAP , CHIP	100PF 50V J
C4276	CCUS1H101JA	CAP , CHIP	100PF 50V J
C4277	CCUS1H101JA	CAP , CHIP	100PF 50V J
C4279	CCUS1H102KC	CAP , CHIP	1000PF 50V K
C4280	CCUS1H102KC	CAP , CHIP	1000PF 50V K
C4281	CCUS1H104KC	CAP , CHIP	0.1UF 50V K
C4283	CCUS1H104KC	CAP , CHIP	0.1UF 50V K
C4284	CCUS1H104KC	CAP , CHIP	0.1UF 50V K
C4285	CCUS1H104KC	CAP , CHIP	0.1UF 50V K
C4287	CCUS1H104KC	CAP , CHIP	0.1UF 50V K
C4288	CCUS1H104KC	CAP , CHIP	0.1UF 50V K
C4289	CCUS1H104KC	CAP , CHIP	0.1UF 50V K
C4290	CCUS1H101JA	CAP , CHIP	100PF 50V J
C4291	CCUS1H104KC	CAP , CHIP	0.1UF 50V K
C4292	CCUS1H104KC	CAP , CHIP	0.1UF 50V K
C4293	CCUS1H104KC	CAP , CHIP	0.1UF 50V K
C4295	CCUS1H104KC	CAP , CHIP	0.1UF 50V K
C4296	CCUS1H104KC	CAP , CHIP	0.1UF 50V K
C4297	CCUS1H104KC	CAP , CHIP	0.1UF 50V K
C4299	CCUS1H104KC	CAP , CHIP	0.1UF 50V K
C4300	CCUS1H392KC	CAP , CHIP CERAMIC(1608, 3900p)	3900PF 50V K
C4301	CCUS1H561JA	CAP , CHIP	560PF 50V J
C4302	CCUS1H220JA	CAP , CHIP	22PF 50V J
C4303	CCUS1H104KC	CAP , CHIP	0.1UF 50V K
C4304	CCUS1H392KC	CAP , CHIP CERAMIC(1608, 3900p)	3900PF 50V K
C4305	CCUS1H561JA	CAP , CHIP	560PF 50V J
C4306	CCUS1H104KC	CAP , CHIP	0.1UF 50V K
C4307	CCUS1H392KC	CAP , CHIP CERAMIC(1608, 3900p)	3900PF 50V K
C4308	CCUS1H561JA	CAP , CHIP	560PF 50V J
C4309	CCUS1H104KC	CAP , CHIP	0.1UF 50V K
C4310	CCUS1H392KC	CAP , CHIP CERAMIC(1608, 3900p)	3900PF 50V K
C4311	CCUS1H561JA	CAP , CHIP	560PF 50V J
C4312	CCUS1H104KC	CAP , CHIP	0.1UF 50V K
C4313	CCUS1H104KC	CAP , CHIP	0.1UF 50V K
C4314	CCUS1H104KC	CAP , CHIP	0.1UF 50V K
C4315	CCUS1H104KC	CAP , CHIP	0.1UF 50V K
C4316	CCUS1H104KC	CAP , CHIP	0.1UF 50V K
C4317	CCUS1H104KC	CAP , CHIP	0.1UF 50V K
C4318	CCUS1H392KC	CAP , CHIP CERAMIC(1608, 3900p)	3900PF 50V K
C4319	CCUS1H561JA	CAP , CHIP	560PF 50V J
C4320	CCUS1H104KC	CAP , CHIP	0.1UF 50V K
C4321	CCUS1H104KC	CAP , CHIP	0.1UF 50V K
C4322	CCUS1H104KC	CAP , CHIP	0.1UF 50V K
C4323	CCUS1H392KC	CAP , CHIP CERAMIC(1608, 3900p)	3900PF 50V K
C4324	CCUS1H561JA	CAP , CHIP	560PF 50V J
C4325	CCUI1A104KC	CAP , CHIP(1005, 10V/0.1UF)	0.1uF 10V X7R 0402
C4327	CCUS1H104KC	CAP , CHIP	0.1UF 50V K
C4328	CCSJA1C100B	CAP , CHIP TANTAL(A TYPE, 10uF/16V, ELNA)	10uF 16V T491B106M016AS 3528
C4329	CCUI1A104KC	CAP , CHIP(1005, 10V/0.1UF)	0.1uF 10V X7R 0402
C4330	CCUS1H104KC	CAP , CHIP	0.1UF 50V K
C4331	CCUS1H392KC	CAP , CHIP CERAMIC(1608, 3900p)	3900PF 50V K
C4332	CCUS1H561JA	CAP , CHIP	560PF 50V J
C4333	CCUS1H104KC	CAP , CHIP	0.1UF 50V K
C4334	CCUS1H104KC	CAP , CHIP	0.1UF 50V K
C4335	CCUS1H392KC	CAP , CHIP CERAMIC(1608, 3900p)	3900PF 50V K
C4336	CCUS1H561JA	CAP , CHIP	560PF 50V J
C4337	CCUI1A104KC	CAP , CHIP(1005, 10V/0.1UF)	0.1uF 10V X7R 0402
C4338	CCUI1A104KC	CAP , CHIP(1005, 10V/0.1UF)	0.1uF 10V X7R 0402
C4339	CCUI1A104KC	CAP , CHIP(1005, 10V/0.1UF)	0.1uF 10V X7R 0402
C4340	CCUI1A104KC	CAP , CHIP(1005, 10V/0.1UF)	0.1uF 10V X7R 0402
C4341	CCUI1A104KC	CAP , CHIP(1005, 10V/0.1UF)	0.1uF 10V X7R 0402
C4342	CCUI1A104KC	CAP , CHIP(1005, 10V/0.1UF)	0.1uF 10V X7R 0402
C4343	CCUI1A104KC	CAP , CHIP(1005, 10V/0.1UF)	0.1uF 10V X7R 0402
C4344	CCUS1H104KC	CAP , CHIP	0.1UF 50V K

Ref. Designator	Part Number	Description	Qty
DSP PCB ASS'Y		COP12038B	
C4345	CCUS1H104KC	CAP , CHIP	0.1UF 50V K
C4346	CCUS1H392KC	CAP , CHIP CERAMIC(1608, 3900p)	3900PF 50V K
C4347	CCUS1H561JA	CAP , CHIP	560PF 50V J
C4348	CCUI1A104KC	CAP , CHIP(1005, 10V/0.1UF)	0.1uF 10V X7R 0402
C4349	CCUS1A105KC	CAP , CHIP	1UF 10V K
C4350	CCUS1H104KC	CAP , CHIP	0.1UF 50V K
C4351	CCUS1H102KC	CAP , CHIP	1000PF 50V K
C4352	CCUS1H392KC	CAP , CHIP CERAMIC(1608, 3900p)	3900PF 50V K
C4353	CCUS1H561JA	CAP , CHIP	560PF 50V J
C4354	CCUI1A104KC	CAP , CHIP(1005, 10V/0.1UF)	0.1uF 10V X7R 0402
C4355	CCUS1H104KC	CAP , CHIP	0.1UF 50V K
C4356	CCSJB1A220B	CAP , CHIP TANTAL(B TYPE, 22uF/10V, ELNA)	22uF 10V T491C226M010AS 6032
C4357	CCUS1H103KC	CAP , CHIP	0.01UF 50V K
C4358	CCUS1H103KC	CAP , CHIP	0.01UF 50V K
C4359	CCUS1H104KC	CAP , CHIP	0.1UF 50V K
C4360	CCUS1H104KC	CAP , CHIP	0.1UF 50V K
C4361	CCUS1H104KC	CAP , CHIP	0.1UF 50V K
C4362	CCUS1H104KC	CAP , CHIP	0.1UF 50V K
C4363	CCUS1H104KC	CAP , CHIP	0.1UF 50V K
C4364	CCUI1A104KC	CAP , CHIP(1005, 10V/0.1UF)	0.1uF 10V X7R 0402
C4365	CCUS1H104KC	CAP , CHIP	0.1UF 50V K
C4366	CCUS1H103KC	CAP , CHIP	0.01UF 50V K
C4367	CCUS1H272KC	CAP , CHIP	2700PF 50V K
C4368	CCUS1H821JA	CAP , CHIP	820PF 50V J
C4369	CCUS1H104KC	CAP , CHIP	0.1UF 50V K
C4370	CCUS1H272KC	CAP , CHIP	2700PF 50V K
C4371	CCUS1H821JA	CAP , CHIP	820PF 50V J
C4372	CCUS1H104KC	CAP , CHIP	0.1UF 50V K
C4373	CCUS1H104KC	CAP , CHIP	0.1UF 50V K
C4374	CCUC1H104KC	CHIP, CAP 0.1UF/50V/2012	100NF 50V Y5V 0805
C4375	CCUS1A105KC	CAP , CHIP	1UF 10V K
C4376	CCUS1H392KC	CAP , CHIP CERAMIC(1608, 3900p)	3900PF 50V K
C4377	CCUS1H561JA	CAP , CHIP	560PF 50V J
C4378	CCUS1H104KC	CAP , CHIP	0.1UF 50V K
C4379	CCUS1H103KC	CAP , CHIP	0.01UF 50V K
C4381	CCUC1H104KC	CHIP, CAP 0.1UF/50V/2012	100NF 50V Y5V 0805
C4382	CCUS1H392KC	CAP , CHIP CERAMIC(1608, 3900p)	3900PF 50V K
C4383	CCUS1H561JA	CAP , CHIP	560PF 50V J
C4384	CCUS1H101JA	CAP , CHIP	100PF 50V J
C4385	CCSJA1C100B	CAP , CHIP TANTAL(A TYPE, 10uF/16V, ELNA)	10uF 16V T491B106M016AS 3528
C4386	CCUS1H104KC	CAP , CHIP	0.1UF 50V K
C4387	CCUS1H104KC	CAP , CHIP	0.1UF 50V K
C4388	CCUS1H101JA	CAP , CHIP	100PF 50V J
C4389	CCUS1H392KC	CAP , CHIP CERAMIC(1608, 3900p)	3900PF 50V K
C4390	CCUS1H561JA	CAP , CHIP	560PF 50V J
C4391	CCUS1H561JA	CAP , CHIP	560PF 50V J
C4392	CCUS1H101JA	CAP , CHIP	100PF 50V J
C4393	CCUS1H104KC	CAP , CHIP	0.1UF 50V K
C4394	CCUS1H104KC	CAP , CHIP	0.1UF 50V K
C4395	CCUS1H104KC	CAP , CHIP	0.1UF 50V K
C4396	CCUS1H104KC	CAP , CHIP	0.1UF 50V K
C4397	CCUS1H392KC	CAP , CHIP CERAMIC(1608, 3900p)	3900PF 50V K
C4398	CCUS1H101JA	CAP , CHIP	100PF 50V J
C4399	CCUS1H104KC	CAP , CHIP	0.1UF 50V K
C4400	CCUS1H104KC	CAP , CHIP	0.1UF 50V K
C4401	CCUS1H101JA	CAP , CHIP	100PF 50V J
C4403	CCUS1H330JA	CAP , CHIP	33PF 50V J
C4404	CCUS1H330JA	CAP , CHIP	33PF 50V J
C4405	CCUS1H104KC	CAP , CHIP	0.1UF 50V K
C4406	CCUS1H104KC	CAP , CHIP	0.1UF 50V K
C4408	CCUS1H104KC	CAP , CHIP	0.1UF 50V K
C4409	CCUS1H220JA	CAP , CHIP	22PF 50V J
C4410	CCUS1H104KC	CAP , CHIP	0.1UF 50V K
C4411	CCUS1H104KC	CAP , CHIP	0.1UF 50V K
C4412	CCUS1H104KC	CAP , CHIP	0.1UF 50V K
C4413	CCUS1H104KC	CAP , CHIP	0.1UF 50V K
C4414	CCUS1H104KC	CAP , CHIP	0.1UF 50V K
C4415	CCUS1H104KC	CAP , CHIP	0.1UF 50V K
C4416	CCUS1H104KC	CAP , CHIP	0.1UF 50V K
C4417	CCUS1H104KC	CAP , CHIP	0.1UF 50V K
C4418	CCUS1H104KC	CAP , CHIP	0.1UF 50V K

Ref. Designator	Part Number	Description	Qty
DSP PCB ASS'Y		COP12038B	
C4419	CCUS1H104KC	CAP , CHIP	0.1UF 50V K
C4420	CCUI1A104KC	CAP , CHIP(1005, 10V/0.1UF)	0.1uF 10V X7R 0402
C4421	CCUS1H104KC	CAP , CHIP	0.1UF 50V K
C4422	CCUS1H272KC	CAP , CHIP	2700PF 50V K
C4423	CCUS1H471JA	CAP , CHIP	470PF 50V J
C4424	CCSJA1C100B	CAP , CHIP TANTAL(A TYPE, 10uF/16V, ELNA)	10uF 16V T491B106M016AS 3528
C4425	CCUI1A104KC	CAP , CHIP(1005, 10V/0.1UF)	0.1uF 10V X7R 0402
C4426	CCUS1H272KC	CAP , CHIP	2700PF 50V K
C4427	CCUS1H471JA	CAP , CHIP	470PF 50V J
C4428	CCUS1H104KC	CAP , CHIP	0.1UF 50V K
C4429	CCUI1A104KC	CAP , CHIP(1005, 10V/0.1UF)	0.1uF 10V X7R 0402
C4430	CCUI1A104KC	CAP , CHIP(1005, 10V/0.1UF)	0.1uF 10V X7R 0402
C4431	CCUI1A104KC	CAP , CHIP(1005, 10V/0.1UF)	0.1uF 10V X7R 0402
C4432	CCUI1A104KC	CAP , CHIP(1005, 10V/0.1UF)	0.1uF 10V X7R 0402
C4433	CCUI1A104KC	CAP , CHIP(1005, 10V/0.1UF)	0.1uF 10V X7R 0402
C4434	CCUI1A104KC	CAP , CHIP(1005, 10V/0.1UF)	0.1uF 10V X7R 0402
C4435	CCUI1A104KC	CAP , CHIP(1005, 10V/0.1UF)	0.1uF 10V X7R 0402
C4436	CCUS1H272KC	CAP , CHIP	2700PF 50V K
C4437	CCUS1H471JA	CAP , CHIP	470PF 50V J
C4438	CCUS1H104KC	CAP , CHIP	0.1UF 50V K
C4439	CCUS1H104KC	CAP , CHIP	0.1UF 50V K
C4440	CCUS1H272KC	CAP , CHIP	2700PF 50V K
C4441	CCUS1H471JA	CAP , CHIP	470PF 50V J
C4442	CCUI1A104KC	CAP , CHIP(1005, 10V/0.1UF)	0.1uF 10V X7R 0402
C4443	CCUS1A105KC	CAP , CHIP	1UF 10V K
C4444	CCUS1H104KC	CAP , CHIP	0.1UF 50V K
C4445	CCUI1A104KC	CAP , CHIP(1005, 10V/0.1UF)	0.1uF 10V X7R 0402
C4446	CCUS1H104KC	CAP , CHIP	0.1UF 50V K
C4447	CCSJB1A220B	CAP , CHIP TANTAL(B TYPE, 22uF/10V, ELNA)	22uF 10V T491C226M010AS 6032
C4448	CCUS1H104KC	CAP , CHIP	0.1UF 50V K
C4449	CCUS1H104KC	CAP , CHIP	0.1UF 50V K
C4450	CCUS1H104KC	CAP , CHIP	0.1UF 50V K
C4451	CCUS1H104KC	CAP , CHIP	0.1UF 50V K
C4452	CCUS1H104KC	CAP , CHIP	0.1UF 50V K
C4453	CCUS1H104KC	CAP , CHIP	0.1UF 50V K
C4454	CCUS1H104KC	CAP , CHIP	0.1UF 50V K
C4455	CCUI1A104KC	CAP , CHIP(1005, 10V/0.1UF)	0.1uF 10V X7R 0402
C4456	CCUS1H104KC	CAP , CHIP	0.1UF 50V K
C4457	CCUS1H104KC	CAP , CHIP	0.1UF 50V K
C4458	CCUS1H104KC	CAP , CHIP	0.1UF 50V K
C4459	CCUS1H104KC	CAP , CHIP	0.1UF 50V K
C4460	CCUS1H104KC	CAP , CHIP	0.1UF 50V K
C4461	CCUS1H104KC	CAP , CHIP	0.1UF 50V K
C4462	CCUS1H104KC	CAP , CHIP	0.1UF 50V K
C4463	CCUS1A105KC	CAP , CHIP	1UF 10V K
C4464	CCUS1H104KC	CAP , CHIP	0.1UF 50V K
C4465	CCUS1H104KC	CAP , CHIP	0.1UF 50V K
C4466	CCUS1H272KC	CAP , CHIP	2700PF 50V K
C4467	CCUS1H122KC	CAP , CHIP	1200PF 50V K
C4468	CCSJA1C100B	CAP , CHIP TANTAL(A TYPE, 10uF/16V, ELNA)	10uF 16V T491B106M016AS 3528
C4469	CCUS1H272KC	CAP , CHIP	2700PF 50V K
C4470	CCUS1H122KC	CAP , CHIP	1200PF 50V K
C4471	CCUS1H104KC	CAP , CHIP	0.1UF 50V K
C4472	CCUS1H104KC	CAP , CHIP	0.1UF 50V K
C4473	CCUS1H104KC	CAP , CHIP	0.1UF 50V K
C4474	CCUS1H222KC	CAP , CHIP	2200PF 50V K
C4475	CCUS1H222KC	CAP , CHIP	2200PF 50V K
C4478	CCUS1H104KC	CAP , CHIP	0.1UF 50V K
C4479	CCUS1H104KC	CAP , CHIP	0.1UF 50V K
C4480	CCUS1H104KC	CAP , CHIP	0.1UF 50V K
C4481	CCUS1H104KC	CAP , CHIP	0.1UF 50V K
C4482	CCUS1H104KC	CAP , CHIP	0.1UF 50V K
C4483	CCUS1H272KC	CAP , CHIP	2700PF 50V K
C4484	CCUS1H471JA	CAP , CHIP	470PF 50V J
C4485	CCUS1H104KC	CAP , CHIP	0.1UF 50V K
C4486	CCUS1H104KC	CAP , CHIP	0.1UF 50V K
C4487	CCUS1H272KC	CAP , CHIP	2700PF 50V K
C4488	CCUS1H104KC	CAP , CHIP	0.1UF 50V K
C4489	CCUS1H104KC	CAP , CHIP	0.1UF 50V K
C4490	CCUS1H471JA	CAP , CHIP	470PF 50V J
C4492	CCUS1H272KC	CAP , CHIP	2700PF 50V K

Ref. Designator	Part Number	Description	Qty
DSP PCB ASS'Y		COP12038B	
C4493	CCUS1H104KC	CAP , CHIP	0.1UF 50V K
C4494	CCUS1H272KC	CAP , CHIP	2700PF 50V K
C4495	CCUS1H471JA	CAP , CHIP	470PF 50V J
C4496	CCUS1H104KC	CAP , CHIP	0.1UF 50V K
C4497	CCUS1H104KC	CAP , CHIP	0.1UF 50V K
C4498	CCUS1H104KC	CAP , CHIP	0.1UF 50V K
C4499	CCUS1H104KC	CAP , CHIP	0.1UF 50V K
C4500	CCUS1H104KC	CAP , CHIP	0.1UF 50V K
C4501	CCUS1H104KC	CAP , CHIP	0.1UF 50V K
C4502	CCUS1H104KC	CAP , CHIP	0.1UF 50V K
C4503	CCUS1H104KC	CAP , CHIP	0.1UF 50V K
C4504	CCUS1H104KC	CAP , CHIP	0.1UF 50V K
C4505	CCUS1H104KC	CAP , CHIP	0.1UF 50V K
C4506	CCUS1H104KC	CAP , CHIP	0.1UF 50V K
C4507	CCUS1H104KC	CAP , CHIP	0.1UF 50V K
C4508	CCUS1H330JA	CAP , CHIP	33PF 50V J
C4509	CCUS1H330JA	CAP , CHIP	33PF 50V J
C4510	CCUS1H101JA	CAP , CHIP	100PF 50V J
C4511	CCUS1H104KC	CAP , CHIP	0.1UF 50V K
C4512	CCUS1H104KC	CAP , CHIP	0.1UF 50V K
C4513	CCUS1H104KC	CAP , CHIP	0.1UF 50V K
C4514	CCUS1H104KC	CAP , CHIP	0.1UF 50V K
C4516	CCUS1H470JA	CAP , CHIP	47PF 50V J
C4517	CCUS1H101JA	CAP , CHIP	100PF 50V J
C4518	CCUS1H101JA	CAP , CHIP	100PF 50V J
C4519	CCUS1H470JA	CAP , CHIP	47PF 50V J
C4520	CCUS1H101JA	CAP , CHIP	100PF 50V J
C4521	CCUS1H101JA	CAP , CHIP	100PF 50V J
C4522	CCUS1H102KC	CAP , CHIP	1000PF 50V K
C4523	CCUS1H102KC	CAP , CHIP	1000PF 50V K
C4524	CCUS1H104KC	CAP , CHIP	0.1UF 50V K
C4525	CCUS1H104KC	CAP , CHIP	0.1UF 50V K
C4527	CCUS1H104KC	CAP , CHIP	0.1UF 50V K
C4528	CCUS1H104KC	CAP , CHIP	0.1UF 50V K
C4529	CCUS1H104KC	CAP , CHIP	0.1UF 50V K
C4530	CCUS1H104KC	CAP , CHIP	0.1UF 50V K
C4531	CCUS1H104KC	CAP , CHIP	0.1UF 50V K
C4000	CCUS1H220JA	CAP , CHIP	22PF 50V J
C4001	CCUS1H104KC	CAP , CHIP	0.1UF 50V K
C4002	CCUS1H104KC	CAP , CHIP	0.1UF 50V K
C4005	CCUS1H104KC	CAP , CHIP	0.1UF 50V K
C4006	CCUS1H220JA	CAP , CHIP	22PF 50V J
C4007	CCUS1H104KC	CAP , CHIP	0.1UF 50V K
C4011	CCUS1H104KC	CAP , CHIP	0.1UF 50V K
C4012	CCUS1H104KC	CAP , CHIP	0.1UF 50V K
C4014	CCUS1H104KC	CAP , CHIP	0.1UF 50V K
C4025	CCUS1H104KC	CAP , CHIP	0.1UF 50V K
C4027	CCUS1H104KC	CAP , CHIP	0.1UF 50V K
C4031	CCUS1H104KC	CAP , CHIP	0.1UF 50V K
C4032	CCUS1H104KC	CAP , CHIP	0.1UF 50V K
C4033	CCUS1H104KC	CAP , CHIP	0.1UF 50V K
C4034	CCUS1H104KC	CAP , CHIP	0.1UF 50V K
C4036	CCUS1H104KC	CAP , CHIP	0.1UF 50V K
C4037	CCUS1H104KC	CAP , CHIP	0.1UF 50V K
C4038	CCUS1H104KC	CAP , CHIP	0.1UF 50V K
C4039	CCUS1H104KC	CAP , CHIP	0.1UF 50V K
C4040	CCUS1H104KC	CAP , CHIP	0.1UF 50V K
C4045	CCUS1H104KC	CAP , CHIP	0.1UF 50V K
C4046	CCUS1H104KC	CAP , CHIP	0.1UF 50V K
C4047	CCUS1H104KC	CAP , CHIP	0.1UF 50V K
C4048	CCUS1H104KC	CAP , CHIP	0.1UF 50V K
C4053	CCUS1H104KC	CAP , CHIP	0.1UF 50V K
C4054	CCUS1H104KC	CAP , CHIP	0.1UF 50V K
C4055	CCUS1H104KC	CAP , CHIP	0.1UF 50V K
C4056	CCUS1H104KC	CAP , CHIP	0.1UF 50V K
C4059	CCUS1H104KC	CAP , CHIP	0.1UF 50V K
C4063	CCUS1H102KC	CAP , CHIP	1000PF 50V K
C4064	CCUS1H102KC	CAP , CHIP	1000PF 50V K
C4065	CCUS1H102KC	CAP , CHIP	1000PF 50V K
C4066	CCUS1H102KC	CAP , CHIP	1000PF 50V K
C4067	CCUS1H102KC	CAP , CHIP	1000PF 50V K

Ref. Designator	Part Number	Description	Qty
DSP PCB ASS'Y		COP12038B	
C4068	CCUS1H102KC	CAP , CHIP	1000PF 50V K
C4078	CCUC1H104KC	CHIP, CAP 0.1UF/50V/2012	100NF 50V Y5V 0805
C4079	CCUC1H104KC	CHIP, CAP 0.1UF/50V/2012	100NF 50V Y5V 0805
C4085	CCUS1H104KC	CAP , CHIP	0.1UF 50V K
C4086	CCSJB1A220B	CAP , CHIP TANTAL(B TYPE, 22uF/10V, ELNA)	22uF 10V T491C226M010AS 6032
C4088	CCUS1H104KC	CAP , CHIP	0.1UF 50V K
C4089	CCUS1H104KC	CAP , CHIP	0.1UF 50V K
C4091	CCUS1H104KC	CAP , CHIP	0.1UF 50V K
C4092	CCUS1H104KC	CAP , CHIP	0.1UF 50V K
C4094	CCSJA1C100B	CAP , CHIP TANTAL(A TYPE, 10uF/16V, ELNA)	10uF 16V T491B106M016AS 3528
C4095	CCUS1H104KC	CAP , CHIP	0.1UF 50V K
C4098	CCUS1H104KC	CAP , CHIP	0.1UF 50V K
C4100	CCUS1H104KC	CAP , CHIP	0.1UF 50V K
C4101	CCUC1H223KC	CAP , CHIP (0.022UF/50V B K X7R 2012)	22nF 50V B K X7R 0805
C4103	CCUS1H103KC	CAP , CHIP	0.01UF 50V K
C4104	CCUC1H102KC	CAP , CHIP	1nF 50V COG J 0805
C4108	CCUS1H104KC	CAP , CHIP	0.1UF 50V K
C4109	CCUS1H104KC	CAP , CHIP	0.1UF 50V K
C4114	CCUS1H104KC	CAP , CHIP	0.1UF 50V K
C4116	CCSJB1A220B	CAP , CHIP TANTAL(B TYPE, 22uF/10V, ELNA)	22uF 10V T491C226M010AS 6032
C4117	CCUS1H330JA	CAP , CHIP	33PF 50V J
C4118	CCUS1H104KC	CAP , CHIP	0.1UF 50V K
C4125	CCUS1H104KC	CAP , CHIP	0.1UF 50V K
C4127	CCUS1H102KC	CAP , CHIP	1000PF 50V K
C4128	CCUS1H104KC	CAP , CHIP	0.1UF 50V K
C4129	CCUS1H471JA	CAP , CHIP	470PF 50V J
C4130	CCUS1H080DA	CAP , CHIP	8PF 50V D
C4131	CCUS1H080DA	CAP , CHIP	8PF 50V D
C4132	CCUS1H471JA	CAP , CHIP	470PF 50V J
C4133	CCUS1H101JA	CAP , CHIP	100PF 50V J
C4134	CCUS1H101JA	CAP , CHIP	100PF 50V J
C4135	CCUS1H104KC	CAP , CHIP	0.1UF 50V K
C4136	CCSJB1A220B	CAP , CHIP TANTAL(B TYPE, 22uF/10V, ELNA)	22uF 10V T491C226M010AS 6032
C4137	CCUS1H104KC	CAP , CHIP	0.1UF 50V K
C4138	CCUS1H102KC	CAP , CHIP	1000PF 50V K
C4140	CCSJA1C100B	CAP , CHIP TANTAL(A TYPE, 10uF/16V, ELNA)	10uF 16V T491B106M016AS 3528
C4145	CCUS1H101JA	CAP , CHIP	100PF 50V J
C4146	CCUS1H101JA	CAP , CHIP	100PF 50V J
C4147	CCUS1H104KC	CAP , CHIP	0.1UF 50V K
C4148	CCUS1H104KC	CAP , CHIP	0.1UF 50V K
C4149	CCUS1H104KC	CAP , CHIP	0.1UF 50V K
C4151	CCUS1H104KC	CAP , CHIP	0.1UF 50V K
C4154	CCUS1H104KC	CAP , CHIP	0.1UF 50V K
C4159	CCSJB1A220B	CAP , CHIP TANTAL(B TYPE, 22uF/10V, ELNA)	22uF 10V T491C226M010AS 6032
C4164	CCUS1H104KC	CAP , CHIP	0.1UF 50V K
C4179	CCUS1H104KC	CAP , CHIP	0.1UF 50V K
C4180	CCUS1H104KC	CAP , CHIP	0.1UF 50V K
C4183	CCUS1H104KC	CAP , CHIP	0.1UF 50V K
C4206	CCUS1H200JA	CAP , CHIP	20pF 50V CH J NP0 0603
C4208	CCUS1H104KC	CAP , CHIP	0.1UF 50V K
C4231	CCUS1H104KC	CAP , CHIP	0.1UF 50V K
C4234	CCUS1H104KC	CAP , CHIP	0.1UF 50V K
C4259	CCUS1H104KC	CAP , CHIP	0.1UF 50V K
C4260	CCUS1H104KC	CAP , CHIP	0.1UF 50V K
C4294	CCUS1H104KC	CAP , CHIP	0.1UF 50V K
C4477	CCUS1H471JA	CAP , CHIP	470PF 50V J
C4491	CCUS1H104KC	CAP , CHIP	0.1UF 50V K
C4003	CCEA1CH101T	CAP , ELECT	100UF 16V
C4013	CCEA1CH220T	CAP , ELECT	22UF 16V
C4017	CCEA1CKS100T25	CAP , ELECT (10UF/16V M 4X5mm P2.5mm)	10UF/16V
C4018	CCEA1CKS100T25	CAP , ELECT (10UF/16V M 4X5mm P2.5mm)	10UF/16V
C4019	CCEA1CKS100T25	CAP , ELECT (10UF/16V M 4X5mm P2.5mm)	10UF/16V
C4020	CCEA1CKS100T25	CAP , ELECT (10UF/16V M 4X5mm P2.5mm)	10UF/16V
C4021	CCEA1CKS100T25	CAP , ELECT (10UF/16V M 4X5mm P2.5mm)	10UF/16V
C4022	CCEA1CKS100T25	CAP , ELECT (10UF/16V M 4X5mm P2.5mm)	10UF/16V
C4023	CCEA1CKS100T25	CAP , ELECT (10UF/16V M 4X5mm P2.5mm)	10UF/16V
C4024	CCEA1CKS100T25	CAP , ELECT (10UF/16V M 4X5mm P2.5mm)	10UF/16V
C4026	CCEA1CH220T	CAP , ELECT	22UF 16V
C4029	CCEA1CH101T	CAP , ELECT	100UF 16V
C4030	CCEA1CH101T	CAP , ELECT	100UF 16V
C4044	CCEA1CH101T	CAP , ELECT	100UF 16V

Ref. Designator	Part Number	Description	Qty
DSP PCB ASS'Y		COP12038B	
C4049	CCEA1CH101T	CAP , ELECT	100UF 16V
C4061	CCEA1CH100T	CAP , ELECT	10UF 16V
C4069	CCEA1CH101T	CAP , ELECT	100UF 16V
C4071	CCEA1CH101T	CAP , ELECT	100UF 16V
C4073	CCEA1CH101T	CAP , ELECT	100UF 16V
C4074	CCEA1HH1R0T	CAP , ELECT	1UF 50V
C4075	CCEA1AH221T	CAP , ELECT	220UF 10V
C4080	CCEA1EH470T	CAP , ELECT	47UF 25V
C4083	CCEA1EH470T	CAP , ELECT	47UF 25V
C4084	CCEA1CH101T	CAP , ELECT	100UF 16V
C4087	CCEA1CK100T25	CAP , ELECT (10UF/16V M 4X5mm P2.5mm)	10UF/16V
C4090	CCEA1CK100T25	CAP , ELECT (10UF/16V M 4X5mm P2.5mm)	10UF/16V
C4096	CCEA1CK100T25	CAP , ELECT (10UF/16V M 4X5mm P2.5mm)	10UF/16V
C4097	CCEA1CK100T25	CAP , ELECT (10UF/16V M 4X5mm P2.5mm)	10UF/16V
C4102	CCEA1CK100T25	CAP , ELECT (10UF/16V M 4X5mm P2.5mm)	10UF/16V
C4105	CCEA1CH101T	CAP , ELECT	100UF 16V
C4106	CCEA1CH101T	CAP , ELECT	100UF 16V
C4107	CCEA1CK100T25	CAP , ELECT (10UF/16V M 4X5mm P2.5mm)	10UF/16V
C4110	CCEA1CH101T	CAP , ELECT	100UF 16V
C4111	CCEA1CK100T25	CAP , ELECT (10UF/16V M 4X5mm P2.5mm)	10UF/16V
C4112	CCEA1CH101T	CAP , ELECT	100UF 16V
C4113	CCEA1CH101T	CAP , ELECT	100UF 16V
C4115	CCEA1CK100T25	CAP , ELECT (10UF/16V M 4X5mm P2.5mm)	10UF/16V
C4119	CCEA1CK100T25	CAP , ELECT (10UF/16V M 4X5mm P2.5mm)	10UF/16V
C4120	CCEA1CH101T	CAP , ELECT	100UF 16V
C4121	CCEA1CH101T	CAP , ELECT	100UF 16V
C4122	CCEA1CH101T	CAP , ELECT	100UF 16V
C4123	CCEA1EH470T25	CAP , ELECT (47UF/25V M 5X11 P2.5mm)	47UF 25V
C4124	CCEA1CK100T25	CAP , ELECT (10UF/16V M 4X5mm P2.5mm)	10UF/16V
C4126	CCEA1EH470T25	CAP , ELECT (47UF/25V M 5X11 P2.5mm)	47UF 25V
C4139	CCEA1CK100T25	CAP , ELECT (10UF/16V M 4X5mm P2.5mm)	10UF/16V
C4141	CCEA1CK100T25	CAP , ELECT (10UF/16V M 4X5mm P2.5mm)	10UF/16V
C4142	CCEA1CH100T	CAP , ELECT	10UF 16V
C4143	CCEA1EH470T25	CAP , ELECT (47UF/25V M 5X11 P2.5mm)	47UF 25V
C4144	CCEA1CK100T25	CAP , ELECT (10UF/16V M 4X5mm P2.5mm)	10UF 16V
C4150	CCEA1EH470T25	CAP , ELECT (47UF/25V M 5X11 P2.5mm)	47UF 25V
C4152	CCEA1CK100T25	CAP , ELECT (10UF/16V M 4X5mm P2.5mm)	10UF 16V
C4153	CCEA1CK100T25	CAP , ELECT (10UF/16V M 4X5mm P2.5mm)	10UF 16V
C4155	CCEA1HH1R0T	CAP , ELECT	1UF 50V
C4156	CCEA1HH1R0T	CAP , ELECT	1UF 50V
C4157	CCEA1EH470T25	CAP , ELECT (47UF/25V M 5X11 P2.5mm)	47UF 25V
C4158	CCEA1EH470T25	CAP , ELECT (47UF/25V M 5X11 P2.5mm)	47UF 25V
C4160	CCEA1CK100T25	CAP , ELECT (10UF/16V M 4X5mm P2.5mm)	10UF 16V
C4161	CCEA1EH470T25	CAP , ELECT (47UF/25V M 5X11 P2.5mm)	47UF 25V
C4162	CCEA1AH471T	CAP , ELECT	470UF 10V
C4163	CCEA1AH471T	CAP , ELECT	470UF 10V
C4165	CCEA1CK100T25	CAP , ELECT (10UF/16V M 4X5mm P2.5mm)	10UF 16V
C4166	CCEA1CK100T25	CAP , ELECT (10UF/16V M 4X5mm P2.5mm)	10UF 16V
C4167	CCEA1CK100T25	CAP , ELECT (10UF/16V M 4X5mm P2.5mm)	10UF 16V
C4168	CCEA1CK100T25	CAP , ELECT (10UF/16V M 4X5mm P2.5mm)	10UF 16V
C4169	CCEA1CK100T25	CAP , ELECT (10UF/16V M 4X5mm P2.5mm)	10UF 16V
C4170	CCEA1HH100T	CAP , ELECT	10UF 50V
C4171	CCEA1CH470T	CAP , ELECT	47UF 16V
C4172	CCEA1HH1R0T	CAP , ELECT	1UF 50V
C4173	CCEA1HH1R0T	CAP , ELECT	1UF 50V
C4174	CCEA1CK100T25	CAP , ELECT (10UF/16V M 4X5mm P2.5mm)	10UF 16V
C4175	CCEA1CK100T25	CAP , ELECT (10UF/16V M 4X5mm P2.5mm)	10UF 16V
C4176	CCEA1CH100T	CAP , ELECT	10UF 16V
C4177	CCEA1CK100T25	CAP , ELECT (10UF/16V M 4X5mm P2.5mm)	10UF 16V
C4178	CCEA1HH4R7T	CAP , ELECT	4.7UF 50V
C4181	CCEA1HH100T	CAP , ELECT	10UF 50V
C4182	CCEA1CH470T	CAP , ELECT	47UF 16V
C4185	CCEA1HH1R0T	CAP , ELECT	1UF 50V
C4186	CCEA1HH1R0T	CAP , ELECT	1UF 50V
C4187	CCEA1AH471T	CAP , ELECT	470UF 10V
C4188	CCEA1AH221T	CAP , ELECT	220UF 10V
C4189	CCEA1EH101T	CAP , ELECT	100UF 25V
C4190	CCEA1EH101T	CAP , ELECT	100UF 25V
C4191	CCEA1AH221T	CAP , ELECT	220UF 10V
C4193	CCEA1AH101T	CAP , ELECT	100UF 10V
C4184	CCESDXJ5R5V334U	CAP , DOUBLE LAYER(ELNA, 5.5V, 0.33F)	DXJ5R5V334U

Ref. Designator	Part Number	Description		Qty
DSP PCB ASS'Y		COP12038B		
<i>Semiconductors</i>				
D4003	CVD1SS355T	DIODE , CHIP	1SS355 35V 225MIOA 2012	1
D4004	CVD1SS355T	DIODE , CHIP	1SS355 35V 225MIOA 2012	1
D4005	CVD1SS355T	DIODE , CHIP	1SS355 35V 225MIOA 2012	1
D4006	CVDPG05GBUSCRTPK	DIODE , ESD PROTECTION USC	PG05GBUSC-RTK/P , KEC	1
D4007	CVDPG05GBUSCRTPK	DIODE , ESD PROTECTION USC	PG05GBUSC-RTK/P , KEC	1
D4010	CVD1SS355T	DIODE , CHIP	1SS355 35V 225MIOA 2012	1
D4011	CVD1SS355T	DIODE , CHIP	1SS355 35V 225MIOA 2012	1
D4012	CVD1SS355T	DIODE , CHIP	1SS355 35V 225MIOA 2012	1
D4013	CVD1SS355T	DIODE , CHIP	1SS355 35V 225MIOA 2012	1
IC4047	CVISN74LVC1G125DBV	I.C , SINGLE BUS BUFFER GATE SOT(SOT-23)DBV	SN74LVC1G125DBVR SOT23	1
IC4048	CVISN74LVC1G125DBV	I.C , SINGLE BUS BUFFER GATE SOT(SOT-23)DBV	SN74LVC1G125DBVR SOT23	1
IC4050	CVISN74LVC1G17DBVR	I.C , SINGLE SCHMITT BUFFER SOT(SOT-23)DBV	SN74LVC1G17DBVR SOT(SOT-23)DBV	1
IC4051	CVISN74LVC1G17DBVR	I.C , SINGLE SCHMITT BUFFER SOT(SOT-23)DBV	SN74LVC1G17DBVR SOT(SOT-23)DBV	1
IC4052	HVINJM2068MDTE1	I.C , DUAL OP AMP	NJM2068MD-TE1	1
IC4053	HVINJM2068MDTE1	I.C , DUAL OP AMP	NJM2068MD-TE1	1
IC4055	CVIBU4094BCF	I.C , CMOS SOP-16	BU4094BCF SOP16	1
IC4059	CVIBU4051BCF	I.C , ANALOG MPX/DEMPX SOP-16	BU4051BCF SOP16	1
IC4060	CVIPC17K1CTN	I.C , PHOTO COUPLER CHIP , PC17K1CTN	PC17K1CTN , KODENSHI	1
IC4061	CVISN74LV125APWR	I.C , QUAD BUS BUFFER TSSOP-14	SN74LV125APWR TSSOP14	1
IC4062	CVISN74LV125APWR	I.C , QUAD BUS BUFFER TSSOP-14	SN74LV125APWR TSSOP14	1
Q4006	HVTKRC107S	TRANSISTOR , CHIP NPN	KRC107S SOT-23	1
Q4007	HVTKRC107S	TRANSISTOR , CHIP NPN	KRC107S SOT-23	1
Q4009	HVTKRC107S	TRANSISTOR , CHIP NPN	KRC107S SOT-23	1
Q4013	HVTKRC107S	TRANSISTOR , CHIP NPN	KRC107S SOT-23	1
Q4014	HVTKRC107S	TRANSISTOR , CHIP NPN	KRC107S SOT-23	1
Q4015	HVTKRC107S	TRANSISTOR , CHIP NPN	KRC107S SOT-23	1
Q4016	HVTKRC107S	TRANSISTOR , CHIP NPN	KRC107S SOT-23	1
Q4018	HVTKRC107S	TRANSISTOR , CHIP NPN	KRC107S SOT-23	1
Q4019	HVTKRC107S	TRANSISTOR , CHIP NPN	KRC107S SOT-23	1
Q4020	HVTKRC107S	TRANSISTOR , CHIP NPN	KRC107S SOT-23	1
D4001	CVD1SS355T	DIODE , CHIP	1SS355 35V 225MIOA 2012	1
D4002	CVD1SS355T	DIODE , CHIP	1SS355 35V 225MIOA 2012	1
D4009	CVD1SS355T	DIODE , CHIP	1SS355 35V 225MIOA 2012	1
IC4000	CVIXMDTIC	I.C , XM V3B	XMDTREV3B DT3B TQFP48	1
IC4001	HVINJM2068MDTE1	I.C , DUAL OP AMP	NJM2068MD-TE1	1
IC4002	HVINJM2068MDTE1	I.C , DUAL OP AMP	NJM2068MD-TE1	1
IC4003	HVINJM2068MDTE1	I.C , DUAL OP AMP	NJM2068MD-TE1	1
IC4004	HVINJM2068MDTE1	I.C , DUAL OP AMP	NJM2068MD-TE1	1
IC4005	HVI74HCU04AFNG	I.C , INVERTER	TC74HCU04AFNG(TOSHIBA)	1
IC4006	HVINJM2068MDTE1	I.C , DUAL OP AMP	NJM2068MD-TE1	1
IC4007	HVINJM2068MDTE1	I.C , DUAL OP AMP	NJM2068MD-TE1	1
IC4008	HVINJM2068MDTE1	I.C , DUAL OP AMP	NJM2068MD-TE1	1
IC4009	HVINJM2068MDTE1	I.C , DUAL OP AMP	NJM2068MD-TE1	1
IC4010	HVINJM2068MDTE1	I.C , DUAL OP AMP	NJM2068MD-TE1	1
IC4011	HVINJM2068MDTE1	I.C , DUAL OP AMP	NJM2068MD-TE1	1
IC4012	HVINJM2068MDTE1	I.C , DUAL OP AMP	NJM2068MD-TE1	1
IC4013	HVINJM2068MDTE1	I.C , DUAL OP AMP	NJM2068MD-TE1	1
IC4015	CVIXC9572XL-5VQG64	IC HIGH PERFO- CPLD VQG-64 XILINX	XC9572XL-5VQG64C, XILINX	1
IC4016	HVITC9162CFG	I.C , FUNCTION SW	TC9162CFG SOP28	1
IC4017	CVICS5368-CQZ	I.C , DSP(CS5368-CQZ REV.B0 ,LQFP-48)	CS5368-CQZ LQFP48 REV B	1
IC4018	HVINJM2068MDTE1	I.C , DUAL OP AMP	NJM2068MD-TE1	1
IC4019	HVIM29W160ET70N	IC,16M FLASH (ST)	M29W160ET-70N6	1
IC4020	CLZ9R014Z	BEAD , FERRITE (ACF451832-333-T)	ACF451832-333-T	1
IC4021	HVINJM2068MDTE1	I.C , DUAL OP AMP	NJM2068MD-TE1	1
IC4022	CVIM12L64164A-5TG	I.C , SDRAM	M12L64164A-5TG , ESMT(ADS)	1
IC4023	CVID790E001BZDH275	I.C , DSP DECODER	D790E001BZDH275 , TI(AVNET)	1
IC4024	CVIKIA1117F00RTFP	I.C , 3-TERMINAL POS V-REG(1.1V-ADJ LOW DROP,DPARK	KIA1117F00-RTF/P , KEC	1
IC4025	HVINJM2068MDTE1	I.C , DUAL OP AMP	NJM2068MD-TE1	1
IC4026	HVICS42528-CQ	I.C , CODEC + DIR	CS42528-CQ	1
IC4027	CVIM12L64164A-5TG	I.C , SDRAM	M12L64164A-5TG , ESMT(ADS)	1
IC4028	HVINJM2068MDTE1	I.C , DUAL OP AMP	NJM2068MD-TE1	1
IC4029	CLZ9R014Z	BEAD , FERRITE (ACF451832-333-T)	ACF451832-333-T	1
IC4030	HVIM29W160ET70N	IC,16M FLASH (ST)	M29W160ET-70N6	1
IC4031	CVIM12L64164A-5TG	I.C , SDRAM	M12L64164A-5TG , ESMT(ADS)	1
IC4032	HVINJM2068MDTE1	I.C , DUAL OP AMP	NJM2068MD-TE1	1
IC4033	CVICS4391A-KZZ	I.C , 24-Bit, 192 kHz Stereo D/A Converter	CS4391A	1
IC4034	CVID790E001BZDH275	I.C , DSP DECODER	D790E001BZDH275 , TI(AVNET)	1
IC4035	CVIKIA1117F00RTFP	I.C , 3-TERMINAL POS V-REG(1.1V-ADJ LOW DROP,DPARK	KIA1117F00-RTF/P , KEC	1
IC4036	CVIM12L64164A-5TG	I.C , SDRAM	M12L64164A-5TG , ESMT(ADS)	1

Ref. Designator	Part Number	Description		Qty
DSP PCB ASS'Y		COP12038B		
IC4037	HVINJM2068MDTE1	I.C , DUAL OP AMP	NJM2068MD-TE1	1
IC4038	CVICS4391A-KZZ	I.C , 24-Bit, 192 kHz Stereo D/A Converter	CS4391A	1
IC4039	HVINJM2068MDTE1	I.C , DUAL OP AMP	NJM2068MD-TE1	1
IC4040	CVICS4391A-KZZ	I.C , CONV(CS4391A-KZZ SOP-20)	CS4391A	1
IC4041	CVIUPD70F3718GC8EA	IC , U-COM, AVR755/655, LQFP 100(14*14), NEC	UPD70F3718GC-8EA-A LQFP100(14*	1
IC4042	CVIM24256BWMN6TP	I.C , EEPROM (256KBits, 400MHz, 2.5-5.5V, SOP-8)	M24256-BWMN6TP , ST	1
IC4043	CVISN74LVC1G125DBV	I.C , SINGLE BUS BUFFER GATE SOT(SOT-23)DBV	SN74LVC1G125DBVR SOT23	1
IC4045	HVILM1117S-3V3	I.C , REGULATOR (3.3V)	1117S-3.3V	1
IC4049	CVISN74LVC1G125DBV	I.C , SINGLE BUS BUFFER GATE SOT(SOT-23)DBV	SN74LVC1G125DBVR SOT23	1
IC4054	CVIBU4094BCF	I.C , 8-bit compatible shift / store register	BU4094BCF SOP16	1
IC4056	CVISN74LVC1G125DBV	I.C , SINGLE BUS BUFFER GATE SOT(SOT-23)DBV	SN74LVC1G125DBVR SOT23	1
IC4057	CVIBU4094BCF	I.C , 8-bit compatible shift / store register	BU4094BCF SOP16	1
IC4058	CVIBU4094BCF	I.C , 8-bit compatible shift / store register	BU4094BCF SOP16	1
IC4063	CVISN74LVC1G125DBV	I.C , SINGLE BUS BUFFER GATE SOT(SOT-23)DBV	SN74LVC1G125DBVR SOT23	1
Q4000	HVTKRC107S	TRANSISTOR , CHIP NPN	KRC107S SOT-23	1
Q4001	HVTKRC107S	TRANSISTOR , CHIP NPN	KRC107S SOT-23	1
Q4002	HVTKRC107S	TRANSISTOR , CHIP NPN	KRC107S SOT-23	1
Q4003	HVTKRC107S	TRANSISTOR , CHIP NPN	KRC107S SOT-23	1
Q4004	HVTKRC107S	TRANSISTOR , CHIP NPN	KRC107S SOT-23	1
Q4005	HVTKRC107S	TRANSISTOR , CHIP NPN	KRC107S SOT-23	1
Q4008	CVTMPA06ATPF	TRANSISTOR , DRIVER(NPN,120V, 500mA TO-92)	MPSA06-AT/PF , KEC	1
Q4010	HVTKRA107MT	TRANSISTOR PNP	KRA107M	1
<i>Resistors</i>				
R4010	CRJ10DJ0R0T	RES , CHIP	0 ohm 1/16W 0% 0603	1
R4011	CRJ10DJ0R0T	RES , CHIP	0 ohm 1/16W 0% 0603	1
R4012	CRJ10DJ0R0T	RES , CHIP	0 ohm 1/16W 0% 0603	1
R4158	CRJ10DJ103T	RES , CHIP	10K ohm 1/16W 5% 0603	1
R4175	CRJ10DJ102T	RES , CHIP	1K ohm 1/16W 5% 0603	1
R4176	CRJ10DJ102T	RES , CHIP	1K ohm 1/16W 5% 0603	1
R4177	CRJ10DJ102T	RES , CHIP	1K ohm 1/16W 5% 0603	1
R4184	CRJ10DJ104T	RES , CHIP	100K ohm 1/16W 5% 0603	1
R4197	CRJ10DJ103T	RES , CHIP	10K ohm 1/16W 5% 0603	1
R4198	CRJ10DJ103T	RES , CHIP	10K ohm 1/16W 5% 0603	1
R4216	CRJ10DJ823T	RES , CHIP	82K ohm 1/16W 5% 0603	1
R4217	CRJ10DJ823T	RES , CHIP	82K ohm 1/16W 5% 0603	1
R4218	CRJ10DJ823T	RES , CHIP	82K ohm 1/16W 5% 0603	1
R4219	CRJ10DJ823T	RES , CHIP	82K ohm 1/16W 5% 0603	1
R4220	CRJ10DJ823T	RES , CHIP	82K ohm 1/16W 5% 0603	1
R4221	CRJ10DJ823T	RES , CHIP	82K ohm 1/16W 5% 0603	1
R4222	CRJ10DJ823T	RES , CHIP	82K ohm 1/16W 5% 0603	1
R4223	CRJ10DJ823T	RES , CHIP	82K ohm 1/16W 5% 0603	1
R4226	CRJ10DJ0R0T	RES , CHIP	0 ohm 1/16W 0% 0603	1
R4228	CRJ10DJ102T	RES , CHIP	1K ohm 1/16W 5% 0603	1
R4230	CRJ10DJ100T	RES , CHIP	10 ohm 1/16W 5% 0603	1
R4231	CRJ10DJ100T	RES , CHIP	10 ohm 1/16W 5% 0603	1
R4232	CRJ10DJ100T	RES , CHIP	10 ohm 1/16W 5% 0603	1
R4233	CRJ10DJ0R0T	RES , CHIP	0 ohm 1/16W 0% 0603	1
R4234	CRJ10DJ101T	RES , CHIP	100 ohm 1/16W 5% 0603	1
R4236	CRJ10DJ0R0T	RES , CHIP	0 ohm 1/16W 0% 0603	1
R4237	CRJ10DJ472T	RES , CHIP	4K7ohm 1/16W 5% 0603	1
R4238	CRJ10DJ104T	RES , CHIP	100K ohm 1/16W 5% 0603	1
R4239	CRJ10DJ750T	RES , CHIP	75 ohm 1/16W 5% 0603	1
R4240	CRJ10DJ750T	RES , CHIP	75 ohm 1/16W 5% 0603	1
R4241	CRJ10DJ750T	RES , CHIP	75 ohm 1/16W 5% 0603	1
R4242	CRJ10DJ821T	RES , CHIP	820 ohm 1/16W 5% 0603	1
R4243	CRJ10DJ821T	RES , CHIP	820 ohm 1/16W 5% 0603	1
R4244	CRJ10DJ332T	RES , CHIP	3K3 ohm 1/16W 5% 0603	1
R4245	CRJ10DJ821T	RES , CHIP	820 ohm 1/16W 5% 0603	1
R4246	CRJ10DJ821T	RES , CHIP	820 ohm 1/16W 5% 0603	1
R4247	CRJ10DJ821T	RES , CHIP	820 ohm 1/16W 5% 0603	1
R4248	CRJ10DJ821T	RES , CHIP	820 ohm 1/16W 5% 0603	1
R4249	CRJ10DJ821T	RES , CHIP	820 ohm 1/16W 5% 0603	1
R4250	CRJ10DJ0R0T	RES , CHIP	0 ohm 1/16W 0% 0603	1
R4251	CRJ10DJ223T	RES , CHIP	22K ohm 1/16W 5% 0603	1
R4252	CRJ10DJ104T	RES , CHIP	100K ohm 1/16W 5% 0603	1
R4253	CRJ10DJ102T	RES , CHIP	1K ohm 1/16W 5% 0603	1
R4254	CRJ10DJ104T	RES , CHIP	100K ohm 1/16W 5% 0603	1
R4255	CRJ10DJ102T	RES , CHIP	1K ohm 1/16W 5% 0603	1
R4256	CRJ10DJ104T	RES , CHIP	100K ohm 1/16W 5% 0603	1

Ref. Designator	Part Number	Description	Qty
DSP PCB ASS'Y		COP12038B	
R4257	CRJ10DJ104T	RES , CHIP	100K ohm 1/16W 5% 0603
R4258	CRJ10DJ682T	RES , CHIP	6K8 ohm 1/16W 5% 0603
R4259	CRJ10DJ104T	RES , CHIP	100K ohm 1/16W 5% 0603
R4260	CRJ10DJ104T	RES , CHIP	100K ohm 1/16W 5% 0603
R4261	CRJ10DJ104T	RES , CHIP	100K ohm 1/16W 5% 0603
R4262	CRJ10DJ104T	RES , CHIP	100K ohm 1/16W 5% 0603
R4263	CRJ10DJ104T	RES , CHIP	100K ohm 1/16W 5% 0603
R4265	CRJ10DJ472T	RES , CHIP	4K7ohm 1/16W 5% 0603
R4266	CRJ10DJ223T	RES , CHIP	22K ohm 1/16W 5% 0603
R4267	CRJ10DJ104T	RES , CHIP	100K ohm 1/16W 5% 0603
R4268	CRJ10DJ473T	RES , CHIP	47K ohm 1/16W 5% 0603
R4269	CRJ10DJ473T	RES , CHIP	47K ohm 1/16W 5% 0603
R4270	CRJ10DJ473T	RES , CHIP	47K ohm 1/16W 5% 0603
R4271	CRJ10DJ473T	RES , CHIP	47K ohm 1/16W 5% 0603
R4272	CRJ10DJ473T	RES , CHIP	47K ohm 1/16W 5% 0603
R4273	CRJ10DJ473T	RES , CHIP	47K ohm 1/16W 5% 0603
R4274	CRJ10DJ473T	RES , CHIP	47K ohm 1/16W 5% 0603
R4275	CRJ10DJ473T	RES , CHIP	47K ohm 1/16W 5% 0603
R4279	CRJ10DJ102T	RES , CHIP	1K ohm 1/16W 5% 0603
R4280	CRJ10DJ152T	RES , CHIP	1K5 ohm 1/16W 5% 0603
R4281	CRJ10DJ153T	RES , CHIP	15K ohm 1/16W 5% 0603
R4282	CRJ10DJ104T	RES , CHIP	100K ohm 1/16W 5% 0603
R4283	CRJ10DJ104T	RES , CHIP	100K ohm 1/16W 5% 0603
R4284	CRJ18AJ101T	RES , CHIP	100 ohm 1/10W 5% 0805
R4285	CRJ10DJ203T	RES , CHIP	20K ohm 1/16W 5% 0603
R4286	CRJ10DJ203T	RES , CHIP	20K ohm 1/16W 5% 0603
R4287	CRJ10DJ203T	RES , CHIP	20K ohm 1/16W 5% 0603
R4288	CRJ10DJ203T	RES , CHIP	20K ohm 1/16W 5% 0603
R4289	CRJ10DJ203T	RES , CHIP	20K ohm 1/16W 5% 0603
R4290	CRJ10DJ203T	RES , CHIP	20K ohm 1/16W 5% 0603
R4291	CRJ10DJ203T	RES , CHIP	20K ohm 1/16W 5% 0603
R4292	CRJ10DJ203T	RES , CHIP	20K ohm 1/16W 5% 0603
R4293	CRJ10DJ152T	RES , CHIP	1K5 ohm 1/16W 5% 0603
R4294	CRJ10DJ152T	RES , CHIP	1K5 ohm 1/16W 5% 0603
R4296	CRJ10DJ0R0T	RES , CHIP	0 ohm 1/16W 0% 0603
R4297	CRJ10DJ331T	RES , CHIP	330 ohm 1/16W 5% 0603
R4298	CRJ10DJ153T	RES , CHIP	15K ohm 1/16W 5% 0603
R4299	CRJ10DJ153T	RES , CHIP	15K ohm 1/16W 5% 0603
R4300	CRJ10DJ103T	RES , CHIP	10K ohm 1/16W 5% 0603
R4301	CRJ10DJ103T	RES , CHIP	10K ohm 1/16W 5% 0603
R4302	CRJ10DJ103T	RES , CHIP	10K ohm 1/16W 5% 0603
R4303	CRJ10DJ103T	RES , CHIP	10K ohm 1/16W 5% 0603
R4304	CRJ10DJ103T	RES , CHIP	10K ohm 1/16W 5% 0603
R4305	CRJ10DJ103T	RES , CHIP	10K ohm 1/16W 5% 0603
R4306	CRJ10DJ103T	RES , CHIP	10K ohm 1/16W 5% 0603
R4307	CRJ10DJ103T	RES , CHIP	10K ohm 1/16W 5% 0603
R4308	CRJ10DJ104T	RES , CHIP	100K ohm 1/16W 5% 0603
R4309	CRJ10DJ100T	RES , CHIP	10 ohm 1/16W 5% 0603
R4311	CRJ18AJ101T	RES , CHIP	100 ohm 1/10W 5% 0805
R4312	CRJ10DJ0R0T	RES , CHIP	0 ohm 1/16W 0% 0603
R4313	CRJ10DJ271T	RES , CHIP	270 ohm 1/16W 5% 0603
R4314	CRJ10DJ100T	RES , CHIP	10 ohm 1/16W 5% 0603
R4315	CRJ10DJ472T	RES , CHIP	4K7ohm 1/16W 5% 0603
R4316	CRJ10DJ103T	RES , CHIP	10K ohm 1/16W 5% 0603
R4317	CRJ10DJ103T	RES , CHIP	10K ohm 1/16W 5% 0603
R4318	CRJ10DJ103T	RES , CHIP	10K ohm 1/16W 5% 0603
R4319	CRJ10DJ103T	RES , CHIP	10K ohm 1/16W 5% 0603
R4320	CRJ10DJ103T	RES , CHIP	10K ohm 1/16W 5% 0603
R4321	CRJ10DJ103T	RES , CHIP	10K ohm 1/16W 5% 0603
R4322	CRJ10DJ103T	RES , CHIP	10K ohm 1/16W 5% 0603
R4323	CRJ10DJ103T	RES , CHIP	10K ohm 1/16W 5% 0603
R4324	CRJ10DJ103T	RES , CHIP	10K ohm 1/16W 5% 0603
R4325	CRJ10DJ103T	RES , CHIP	10K ohm 1/16W 5% 0603
R4326	CRJ10DJ103T	RES , CHIP	10K ohm 1/16W 5% 0603
R4327	CRJ10DJ103T	RES , CHIP	10K ohm 1/16W 5% 0603
R4328	CRJ10DJ103T	RES , CHIP	10K ohm 1/16W 5% 0603
R4329	CRJ10DJ103T	RES , CHIP	10K ohm 1/16W 5% 0603
R4330	CRJ10DJ103T	RES , CHIP	10K ohm 1/16W 5% 0603
R4331	CRJ10DJ103T	RES , CHIP	10K ohm 1/16W 5% 0603
R4332	CRJ10DJ470T	RES , CHIP	47 ohm 1/16W 5% 0603
R4333	CRJ10DJ470T	RES , CHIP	47 ohm 1/16W 5% 0603

Ref. Designator	Part Number	Description	Qty
DSP PCB ASS'Y		COP12038B	
R4337	CRJ10DJ100T	RES , CHIP	10 ohm 1/16W 5% 0603
R4341	CRJ18AJ101T	RES , CHIP	100 ohm 1/10W 5% 0805
R4343	CRJ10DJ100T	RES , CHIP	10 ohm 1/16W 5% 0603
R4344	CRJ10DJ220T	RES , CHIP	22 ohm 1/16W 5% 0603
R4345	CRJ10DJ100T	RES , CHIP	10 ohm 1/16W 5% 0603
R4346	CRJ10DJ220T	RES , CHIP	22 ohm 1/16W 5% 0603
R4350	CRJ10DJ100T	RES , CHIP	10 ohm 1/16W 5% 0603
R4351	CRJ10DJ220T	RES , CHIP	22 ohm 1/16W 5% 0603
R4352	CRJ10DJ472T	RES , CHIP	4K7ohm 1/16W 5% 0603
R4353	CRJ10DJ474T	RES , CHIP	470K ohm 1/16W 5% 0603
R4354	CRJ10DJ474T	RES , CHIP	470K ohm 1/16W 5% 0603
R4355	CRJ10DJ472T	RES , CHIP	4K7ohm 1/16W 5% 0603
R4356	CRJ10DJ100T	RES , CHIP	10 ohm 1/16W 5% 0603
R4357	CRJ10DJ220T	RES , CHIP	22 ohm 1/16W 5% 0603
R4358	CRJ18AJ101T	RES , CHIP	100 ohm 1/10W 5% 0805
R4359	CRJ10DJ472T	RES , CHIP	4K7ohm 1/16W 5% 0603
R4360	CRJ10DJ472T	RES , CHIP	4K7ohm 1/16W 5% 0603
R4361	CRJ10DJ103T	RES , CHIP	10K ohm 1/16W 5% 0603
R4362	CRJ10DJ100T	RES , CHIP	10 ohm 1/16W 5% 0603
R4363	CRJ10DJ100T	RES , CHIP	10 ohm 1/16W 5% 0603
R4364	CRJ10DJ102T	RES , CHIP	1K ohm 1/16W 5% 0603
R4365	CRJ10DJ100T	RES , CHIP	10 ohm 1/16W 5% 0603
R4366	CRJ10DJ100T	RES , CHIP	10 ohm 1/16W 5% 0603
R4367	CRJ10DJ100T	RES , CHIP	10 ohm 1/16W 5% 0603
R4368	CRJ10DJ470T	RES , CHIP	47 ohm 1/16W 5% 0603
R4369	CRJ10DJ100T	RES , CHIP	10 ohm 1/16W 5% 0603
R4370	CRJ10DJ103T	RES , CHIP	10K ohm 1/16W 5% 0603
R4371	CRJ10DJ100T	RES , CHIP	10 ohm 1/16W 5% 0603
R4372	CRJ10DJ101T	RES , CHIP	100 ohm 1/16W 5% 0603
R4373	CRJ18AJ101T	RES , CHIP	100 ohm 1/10W 5% 0805
R4374	CRJ10DJ103T	RES , CHIP	10K ohm 1/16W 5% 0603
R4375	CRJ10DJ220T	RES , CHIP	22 ohm 1/16W 5% 0603
R4376	CRJ10DJ220T	RES , CHIP	22 ohm 1/16W 5% 0603
R4377	CRJ10DJ220T	RES , CHIP	22 ohm 1/16W 5% 0603
R4378	CRJ10DJ470T	RES , CHIP	47 ohm 1/16W 5% 0603
R4379	CRJ10DJ100T	RES , CHIP	10 ohm 1/16W 5% 0603
R4381	CRJ10DJ103T	RES , CHIP	10K ohm 1/16W 5% 0603
R4382	CRJ10DJ103T	RES , CHIP	10K ohm 1/16W 5% 0603
R4383	CRJ10DJ122T	RES , CHIP	1K2 ohm 1/16W 5% 0603
R4384	CRJ10DJ562T	RES , CHIP	5K6 ohm 1/16W 5% 0603
R4385	CRJ10DJ103T	RES , CHIP	10K ohm 1/16W 5% 0603
R4386	CRJ10DJ103T	RES , CHIP	10K ohm 1/16W 5% 0603
R4387	CRJ10DJ473T	RES , CHIP	47K ohm 1/16W 5% 0603
R4388	CRJ10DJ103T	RES , CHIP	10K ohm 1/16W 5% 0603
R4389	CRJ10DJ103T	RES , CHIP	10K ohm 1/16W 5% 0603
R4390	CRJ10DJ103T	RES , CHIP	10K ohm 1/16W 5% 0603
R4391	CRJ10DJ122T	RES , CHIP	1K2 ohm 1/16W 5% 0603
R4392	CRJ10DJ104T	RES , CHIP	100K ohm 1/16W 5% 0603
R4393	CRJ10DJ122T	RES , CHIP	1K2 ohm 1/16W 5% 0603
R4394	CRJ10DJ470T	RES , CHIP	47 ohm 1/16W 5% 0603
R4396	CRJ10DJ122T	RES , CHIP	1K2 ohm 1/16W 5% 0603
R4397	CRJ10DJ562T	RES , CHIP	5K6 ohm 1/16W 5% 0603
R4398	CRJ10DJ104T	RES , CHIP	100K ohm 1/16W 5% 0603
R4399	CRJ10DJ102T	RES , CHIP	1K ohm 1/16W 5% 0603
R4400	CRJ10DJ472T	RES , CHIP	4K7ohm 1/16W 5% 0603
R4402	CRJ10DJ470T	RES , CHIP	47 ohm 1/16W 5% 0603
R4403	CRJ10DJ122T	RES , CHIP	1K2 ohm 1/16W 5% 0603
R4404	CRJ10DJ562T	RES , CHIP	5K6 ohm 1/16W 5% 0603
R4405	CRJ10DJ122T	RES , CHIP	1K2 ohm 1/16W 5% 0603
R4406	CRJ10DJ104T	RES , CHIP	100K ohm 1/16W 5% 0603
R4407	CRJ10DJ680T	RES , CHIP	68 ohm 1/16W 5% 0603
R4408	CRJ104DJ330T	RES , 4ARRAY (1608*4)	33ohm 1/16W 5% CN34JT330
R4409	CRJ10DJ122T	RES , CHIP	1K2 ohm 1/16W 5% 0603
R4410	CRJ104DJ330T	RES , 4ARRAY (1608*4)	33ohm 1/16W 5% CN34JT330
R4411	CRJ10DJ122T	RES , CHIP	1K2 ohm 1/16W 5% 0603
R4412	CRJ10DJ562T	RES , CHIP	5K6 ohm 1/16W 5% 0603
R4413	CRJ10DJ104T	RES , CHIP	100K ohm 1/16W 5% 0603
R4414	CRJ10DJ102T	RES , CHIP	1K ohm 1/16W 5% 0603
R4418	CRJ10DJ473T	RES , CHIP	47K ohm 1/16W 5% 0603
R4419	CRJ104DJ330T	RES , 4ARRAY (1608*4)	33ohm 1/16W 5% CN34JT330
R4420	CRJ10DJ470T	RES , CHIP	47 ohm 1/16W 5% 0603

Ref. Designator	Part Number	Description	Qty
DSP PCB ASS'Y		COP12038B	
R4422	CRJ10DJ122T	RES , CHIP	1K2 ohm 1/16W 5% 0603
R4423	CRJ10DJ562T	RES , CHIP	5K6 ohm 1/16W 5% 0603
R4424	CRJ104DJ330T	RES , 4ARRAY (1608*4)	33ohm 1/16W 5% CN34JT330
R4425	CRJ10DJ122T	RES , CHIP	1K2 ohm 1/16W 5% 0603
R4426	CRJ10DJ104T	RES , CHIP	100K ohm 1/16W 5% 0603
R4427	CRJ10DJ103T	RES , CHIP	10K ohm 1/16W 5% 0603
R4428	CRJ10DJ330T	RES , CHIP	33 ohm 1/16W 5% 0603
R4429	CRJ10DF1000T	RES , CHIP 1%	10 ohm 1/16W 1% 0603
R4430	CRJ10DJ121T	RES , CHIP	120 ohm 1/16W 5% 0603
R4431	CRJ10DJ470T	RES , CHIP	47 ohm 1/16W 5% 0603
R4432	CRJ10DJ473T	RES , CHIP	47K ohm 1/16W 5% 0603
R4433	CRJ10DJ122T	RES , CHIP	1K2 ohm 1/16W 5% 0603
R4434	CRJ10DJ183T	RES , CHIP	18K ohm 1/16W 5% 0603
R4435	CRJ10DJ470T	RES , CHIP	47 ohm 1/16W 5% 0603
R4436	CRJ10DJ122T	RES , CHIP	1K2 ohm 1/16W 5% 0603
R4437	CRJ10DJ183T	RES , CHIP	18K ohm 1/16W 5% 0603
R4438	CRJ10DJ104T	RES , CHIP	100K ohm 1/16W 5% 0603
R4439	CRJ10DJ103T	RES , CHIP	10K ohm 1/16W 5% 0603
R4440	CRJ10DJ103T	RES , CHIP	10K ohm 1/16W 5% 0603
R4441	CRJ10DJ4R7T	RES , CHIP	4R7 ohm 1/16W 5% 0603
R4442	CRJ10DJ471T	RES , CHIP	470 ohm 1/16W 5% 0603
R4443	CRJ10DJ472T	RES , CHIP	4K7ohm 1/16W 5% 0603
R4444	CRJ10DJ122T	RES , CHIP	1K2 ohm 1/16W 5% 0603
R4445	CRJ10DJ562T	RES , CHIP	5K6 ohm 1/16W 5% 0603
R4446	CRJ18AJ101T	RES , CHIP	100 ohm 1/10W 5% 0805
R4447	CRJ10DJ153T	RES , CHIP	15K ohm 1/16W 5% 0603
R4448	CRJ10DJ222T	RES , CHIP	2K2 ohm 1/16W 5% 0603
R4449	CRJ10DJ122T	RES , CHIP	1K2 ohm 1/16W 5% 0603
R4450	CRJ10DJ100T	RES , CHIP	10 ohm 1/16W 5% 0603
R4451	CRJ10DJ100T	RES , CHIP	10 ohm 1/16W 5% 0603
R4452	CRJ10DJ122T	RES , CHIP	1K2 ohm 1/16W 5% 0603
R4453	CRJ10DJ472T	RES , CHIP	4K7ohm 1/16W 5% 0603
R4454	CRJ10DJ473T	RES , CHIP	47K ohm 1/16W 5% 0603
R4455	CRJ10DJ104T	RES , CHIP	100K ohm 1/16W 5% 0603
R4456	CRJ10DJ472T	RES , CHIP	4K7ohm 1/16W 5% 0603
R4457	CRJ10DJ122T	RES , CHIP	1K2 ohm 1/16W 5% 0603
R4458	CRJ10DJ122T	RES , CHIP	1K2 ohm 1/16W 5% 0603
R4459	CRJ10DJ472T	RES , CHIP	4K7ohm 1/16W 5% 0603
R4460	CRJ10DJ101T	RES , CHIP	100 ohm 1/16W 5% 0603
R4461	CRJ10DJ122T	RES , CHIP	1K2 ohm 1/16W 5% 0603
R4462	CRJ10DJ562T	RES , CHIP	5K6 ohm 1/16W 5% 0603
R4463	CRJ10DJ104T	RES , CHIP	100K ohm 1/16W 5% 0603
R4464	CRJ10DJ101T	RES , CHIP	100 ohm 1/16W 5% 0603
R4465	CRJ10DJ102T	RES , CHIP	1K ohm 1/16W 5% 0603
R4466	CRJ10DJ153T	RES , CHIP	15K ohm 1/16W 5% 0603
R4467	CRJ10DJ472T	RES , CHIP	4K7ohm 1/16W 5% 0603
R4468	CRJ10DJ472T	RES , CHIP	4K7ohm 1/16W 5% 0603
R4469	CRJ10DJ102T	RES , CHIP	1K ohm 1/16W 5% 0603
R4470	CRJ10DJ103T	RES , CHIP	10K ohm 1/16W 5% 0603
R4471	CRJ10DJ103T	RES , CHIP	10K ohm 1/16W 5% 0603
R4472	CRJ10DJ221T	RES , CHIP	220 ohm 1/16W 5% 0603
R4474	CRJ10DJ222T	RES , CHIP	2K2 ohm 1/16W 5% 0603
R4475	CRJ10DJ222T	RES , CHIP	2K2 ohm 1/16W 5% 0603
R4476	CRJ10DJ473T	RES , CHIP	47K ohm 1/16W 5% 0603
R4478	CRJ10DJ103T	RES , CHIP	10K ohm 1/16W 5% 0603
R4479	CRJ10DJ103T	RES , CHIP	10K ohm 1/16W 5% 0603
R4480	CRJ10DJ102T	RES , CHIP	1K ohm 1/16W 5% 0603
R4481	CRJ10DJ103T	RES , CHIP	10K ohm 1/16W 5% 0603
R4482	CRJ10DJ103T	RES , CHIP	10K ohm 1/16W 5% 0603
R4483	CRJ10DJ103T	RES , CHIP	10K ohm 1/16W 5% 0603
R4485	CRJ10DJ473T	RES , CHIP	47K ohm 1/16W 5% 0603
R4486	CRJ10DJ101T	RES , CHIP	100 ohm 1/16W 5% 0603
R4487	CRJ10DJ100T	RES , CHIP	10 ohm 1/16W 5% 0603
R4488	CRJ10DJ100T	RES , CHIP	10 ohm 1/16W 5% 0603
R4489	CRJ10DJ472T	RES , CHIP	4K7ohm 1/16W 5% 0603
R4490	CRJ104DJ330T	RES , 4ARRAY (1608*4)	33ohm 1/16W 5% CN34JT330
R4491	CRJ10DJ202T	RES , CHIP	2K ohm 1/16W 5% 0603
R4492	CRJ10DJ472T	RES , CHIP	4K7ohm 1/16W 5% 0603
R4493	CRJ10DJ100T	RES , CHIP	10 ohm 1/16W 5% 0603
R4494	CRJ10DJ202T	RES , CHIP	2K ohm 1/16W 5% 0603
R4495	CRJ10DJ561T	RES , CHIP	560 ohm 1/16W 5% 0603

Ref. Designator	Part Number	Description	Qty
DSP PCB ASS'Y		COP12038B	
R4496	CRJ10DJ100T	RES , CHIP	10 ohm 1/16W 5% 0603
R4497	CRJ104DJ330T	RES , 4ARRAY (1608*4)	33ohm 1/16W 5% CN34JT330
R4498	CRJ10DJ100T	RES , CHIP	10 ohm 1/16W 5% 0603
R4499	CRJ104DJ330T	RES , 4ARRAY (1608*4)	33ohm 1/16W 5% CN34JT330
R4500	CRJ10DJ202T	RES , CHIP	2K ohm 1/16W 5% 0603
R4501	CRJ10DJ561T	RES , CHIP	560 ohm 1/16W 5% 0603
R4502	CRJ10DJ104T	RES , CHIP	100K ohm 1/16W 5% 0603
R4503	CRJ10DJ100T	RES , CHIP	10 ohm 1/16W 5% 0603
R4504	CRJ10DJ202T	RES , CHIP	2K ohm 1/16W 5% 0603
R4505	CRJ10DJ472T	RES , CHIP	4K7ohm 1/16W 5% 0603
R4506	CRJ10DJ100T	RES , CHIP	10 ohm 1/16W 5% 0603
R4507	CRJ10DJ102T	RES , CHIP	1K ohm 1/16W 5% 0603
R4508	CRJ104DJ330T	RES , 4ARRAY (1608*4)	33ohm 1/16W 5% CN34JT330
R4510	CRJ18AJ101T	RES , CHIP	100 ohm 1/10W 5% 0805
R4511	CRJ10DJ104T	RES , CHIP	100K ohm 1/16W 5% 0603
R4512	CRJ10DJ330T	RES , CHIP	33 ohm 1/16W 5% 0603
R4513	CRJ10DJ121T	RES , CHIP	120 ohm 1/16W 5% 0603
R4514	CRJ10DJ103T	RES , CHIP	10K ohm 1/16W 5% 0603
R4515	CRJ10DJ4R7T	RES , CHIP	4R7 ohm 1/16W 5% 0603
R4516	CRJ18AJ101T	RES , CHIP	100 ohm 1/10W 5% 0805
R4517	CRJ10DJ103T	RES , CHIP	10K ohm 1/16W 5% 0603
R4518	CRJ10DJ103T	RES , CHIP	10K ohm 1/16W 5% 0603
R4519	CRJ10DJ472T	RES , CHIP	4K7ohm 1/16W 5% 0603
R4520	CRJ10DJ472T	RES , CHIP	4K7ohm 1/16W 5% 0603
R4521	CRJ10DJ471T	RES , CHIP	470 ohm 1/16W 5% 0603
R4522	CRJ10DJ202T	RES , CHIP	2K ohm 1/16W 5% 0603
R4523	CRJ10DJ561T	RES , CHIP	560 ohm 1/16W 5% 0603
R4524	CRJ10DJ202T	RES , CHIP	2K ohm 1/16W 5% 0603
R4525	CRJ10DJ104T	RES , CHIP	100K ohm 1/16W 5% 0603
R4526	CRJ10DJ472T	RES , CHIP	4K7ohm 1/16W 5% 0603
R4527	CRJ10DJ104T	RES , CHIP	100K ohm 1/16W 5% 0603
R4528	CRJ10DJ104T	RES , CHIP	100K ohm 1/16W 5% 0603
R4529	CRJ10DJ102T	RES , CHIP	1K ohm 1/16W 5% 0603
R4530	CRJ10DJ104T	RES , CHIP	100K ohm 1/16W 5% 0603
R4531	CRJ10DJ104T	RES , CHIP	100K ohm 1/16W 5% 0603
R4532	CRJ10DJ221T	RES , CHIP	220 ohm 1/16W 5% 0603
R4533	CRJ10DJ472T	RES , CHIP	4K7ohm 1/16W 5% 0603
R4534	CRJ10DJ332T	RES , CHIP	3K3 ohm 1/16W 5% 0603
R4535	CRJ10DJ561T	RES , CHIP	560 ohm 1/16W 5% 0603
R4536	CRJ10DJ561T	RES , CHIP	560 ohm 1/16W 5% 0603
R4537	CRJ10DJ221T	RES , CHIP	220 ohm 1/16W 5% 0603
R4538	CRJ10DJ471T	RES , CHIP	470 ohm 1/16W 5% 0603
R4539	CRJ18AJ101T	RES , CHIP	100 ohm 1/10W 5% 0805
R4541	CRJ10DJ472T	RES , CHIP	4K7ohm 1/16W 5% 0603
R4542	CRJ10DJ561T	RES , CHIP	560 ohm 1/16W 5% 0603
R4543	CRJ10DJ102T	RES , CHIP	1K ohm 1/16W 5% 0603
R4544	CRJ10DJ102T	RES , CHIP	1K ohm 1/16W 5% 0603
R4545	CRJ10DJ102T	RES , CHIP	1K ohm 1/16W 5% 0603
R4546	CRJ10DJ472T	RES , CHIP	4K7ohm 1/16W 5% 0603
R4547	CRJ10DJ472T	RES , CHIP	4K7ohm 1/16W 5% 0603
R4548	CRJ10DJ561T	RES , CHIP	560 ohm 1/16W 5% 0603
R4549	CRJ10DJ472T	RES , CHIP	4K7ohm 1/16W 5% 0603
R4550	CRJ10DJ472T	RES , CHIP	4K7ohm 1/16W 5% 0603
R4551	CRJ10DJ104T	RES , CHIP	100K ohm 1/16W 5% 0603
R4552	CRJ10DJ103T	RES , CHIP	10K ohm 1/16W 5% 0603
R4553	CRJ10DJ104T	RES , CHIP	100K ohm 1/16W 5% 0603
R4554	CRJ10DJ103T	RES , CHIP	10K ohm 1/16W 5% 0603
R4555	CRJ10DJ104T	RES , CHIP	100K ohm 1/16W 5% 0603
R4556	CRJ10DJ392T	RES , CHIP	3K9 ohm 1/16W 5% 0603
R4558	CRJ10DJ473T	RES , CHIP	47K ohm 1/16W 5% 0603
R4559	CRJ10DJ0R0T	RES , CHIP	0 ohm 1/16W 0% 0603
R4560	CRJ10DJ0R0T	RES , CHIP	0 ohm 1/16W 0% 0603
R4561	CRJ10DJ474T	RES , CHIP	470K ohm 1/16W 5% 0603
R4562	CRJ10DJ101T	RES , CHIP	100 ohm 1/16W 5% 0603
R4563	CRJ10DJ472T	RES , CHIP	4K7ohm 1/16W 5% 0603
R4564	CRJ10DJ0R0T	RES , CHIP	0 ohm 1/16W 0% 0603
R4565	CRJ10DJ0R0T	RES , CHIP	0 ohm 1/16W 0% 0603
R4566	CRJ10DJ103T	RES , CHIP	10K ohm 1/16W 5% 0603
R4568	CRJ10DJ103T	RES , CHIP	10K ohm 1/16W 5% 0603
R4569	CRJ10DJ222T	RES , CHIP	2K2 ohm 1/16W 5% 0603
R4570	CRJ10DJ222T	RES , CHIP	2K2 ohm 1/16W 5% 0603

Ref. Designator	Part Number	Description	Qty
DSP PCB ASS'Y		COP12038B	
R4571	CRJ10DJ222T	RES , CHIP	2K2 ohm 1/16W 5% 0603
R4574	CRJ10DJ103T	RES , CHIP	10K ohm 1/16W 5% 0603
R4578	CRJ10DJ103T	RES , CHIP	10K ohm 1/16W 5% 0603
R4579	CRJ10DJ103T	RES , CHIP	10K ohm 1/16W 5% 0603
R4580	CRJ10DJ222T	RES , CHIP	2K2 ohm 1/16W 5% 0603
R4581	CRJ10DJ222T	RES , CHIP	2K2 ohm 1/16W 5% 0603
R4582	CRJ10DJ221T	RES , CHIP	220 ohm 1/16W 5% 0603
R4583	CRJ10DJ221T	RES , CHIP	220 ohm 1/16W 5% 0603
R4584	CRJ10DJ221T	RES , CHIP	220 ohm 1/16W 5% 0603
R4586	CRJ10DJ102T	RES , CHIP	1K ohm 1/16W 5% 0603
R4000	CRJ10DJ105T	RES , CHIP	1M ohm 1/16W 5% 0603
R4001	CRJ10DJ223T	RES , CHIP	22K ohm 1/16W 5% 0603
R4002	CRJ10DJ223T	RES , CHIP	22K ohm 1/16W 5% 0603
R4003	CRJ10DJ223T	RES , CHIP	22K ohm 1/16W 5% 0603
R4004	CRJ18AJ101T	RES , CHIP	100 ohm 1/10W 5% 0805
R4005	CRJ10DJ331T	RES , CHIP	330 ohm 1/16W 5% 0603
R4013	CRJ10DJ101T	RES , CHIP	100 ohm 1/16W 5% 0603
R4014	CRJ10DJ331T	RES , CHIP	330 ohm 1/16W 5% 0603
R4017	CRJ10DJ331T	RES , CHIP	330 ohm 1/16W 5% 0603
R4020	CRJ10DJ470T	RES , CHIP	47 ohm 1/16W 5% 0603
R4021	CRJ10DJ470T	RES , CHIP	47 ohm 1/16W 5% 0603
R4022	CRJ10DJ470T	RES , CHIP	47 ohm 1/16W 5% 0603
R4023	CRJ10DJ470T	RES , CHIP	47 ohm 1/16W 5% 0603
R4024	CRJ10DJ0R0T	RES , CHIP	0 ohm 1/16W 0% 0603
R4025	CRJ18AJ101T	RES , CHIP	100 ohm 1/10W 5% 0805
R4026	CRJ10DJ470T	RES , CHIP	47 ohm 1/16W 5% 0603
R4027	CRJ10DJ0R0T	RES , CHIP	0 ohm 1/16W 0% 0603
R4028	CRJ10DJ331T	RES , CHIP	330 ohm 1/16W 5% 0603
R4029	CRJ10DJ331T	RES , CHIP	330 ohm 1/16W 5% 0603
R4030	CRJ10DJ331T	RES , CHIP	330 ohm 1/16W 5% 0603
R4031	CRJ10DJ470T	RES , CHIP	47 ohm 1/16W 5% 0603
R4032	CRJ10DJ0R0T	RES , CHIP	0 ohm 1/16W 0% 0603
R4033	CRJ10DJ0R0T	RES , CHIP	0 ohm 1/16W 0% 0603
R4034	CRJ10DJ331T	RES , CHIP	330 ohm 1/16W 5% 0603
R4035	CRJ10DJ331T	RES , CHIP	330 ohm 1/16W 5% 0603
R4036	CRJ10DJ331T	RES , CHIP	330 ohm 1/16W 5% 0603
R4037	CRJ10DJ331T	RES , CHIP	330 ohm 1/16W 5% 0603
R4038	CRJ10DJ331T	RES , CHIP	330 ohm 1/16W 5% 0603
R4039	CRJ10DJ331T	RES , CHIP	330 ohm 1/16W 5% 0603
R4040	CRJ10DJ331T	RES , CHIP	330 ohm 1/16W 5% 0603
R4041	CRJ10DJ331T	RES , CHIP	330 ohm 1/16W 5% 0603
R4042	CRJ10DJ331T	RES , CHIP	330 ohm 1/16W 5% 0603
R4043	CRJ10DJ331T	RES , CHIP	330 ohm 1/16W 5% 0603
R4044	CRJ10DJ331T	RES , CHIP	330 ohm 1/16W 5% 0603
R4045	CRJ10DJ331T	RES , CHIP	330 ohm 1/16W 5% 0603
R4046	CRJ10DJ331T	RES , CHIP	330 ohm 1/16W 5% 0603
R4047	CRJ10DJ331T	RES , CHIP	330 ohm 1/16W 5% 0603
R4048	CRJ10DJ331T	RES , CHIP	330 ohm 1/16W 5% 0603
R4049	CRJ10DJ331T	RES , CHIP	330 ohm 1/16W 5% 0603
R4050	CRJ18AJ101T	RES , CHIP	100 ohm 1/10W 5% 0805
R4051	CRJ10DJ100T	RES , CHIP	10 ohm 1/16W 5% 0603
R4053	CRJ10DJ100T	RES , CHIP	10 ohm 1/16W 5% 0603
R4057	CRJ10DJ101T	RES , CHIP	100 ohm 1/16W 5% 0603
R4059	CRJ10DF1000T	RES , CHIP 1%	10 ohm 1/16W 1% 0603
R4060	CRJ10DF1000T	RES , CHIP 1%	10 ohm 1/16W 1% 0603
R4061	CRJ10DJ470T	RES , CHIP	47 ohm 1/16W 5% 0603
R4062	CRJ10DJ102T	RES , CHIP	1K ohm 1/16W 5% 0603
R4063	CRJ10DJ102T	RES , CHIP	1K ohm 1/16W 5% 0603
R4064	CRJ10DJ470T	RES , CHIP	47 ohm 1/16W 5% 0603
R4065	CRJ10DJ472T	RES , CHIP	4K7ohm 1/16W 5% 0603
R4066	CRJ10DJ470T	RES , CHIP	47 ohm 1/16W 5% 0603
R4067	CRJ10DJ470T	RES , CHIP	47 ohm 1/16W 5% 0603
R4068	CRJ10DJ472T	RES , CHIP	4K7ohm 1/16W 5% 0603
R4069	CRJ10DJ562T	RES , CHIP	5K6 ohm 1/16W 5% 0603
R4070	CRJ10DJ561T	RES , CHIP	560 ohm 1/16W 5% 0603
R4071	CRJ10DJ470T	RES , CHIP	47 ohm 1/16W 5% 0603
R4072	CRJ10DJ470T	RES , CHIP	47 ohm 1/16W 5% 0603
R4073	CRJ10DJ472T	RES , CHIP	4K7ohm 1/16W 5% 0603
R4074	CRJ10DJ562T	RES , CHIP	5K6 ohm 1/16W 5% 0603
R4075	CRJ10DJ472T	RES , CHIP	4K7ohm 1/16W 5% 0603
R4076	CRJ10DJ561T	RES , CHIP	560 ohm 1/16W 5% 0603

Ref. Designator	Part Number	Description	Qty
DSP PCB ASS'Y		COP12038B	
R4077	CRJ10DJ101T	RES , CHIP	100 ohm 1/16W 5% 0603
R4078	CRJ10DJ472T	RES , CHIP	4K7ohm 1/16W 5% 0603
R4079	CRJ064IJ330T	RES , CHIP NETWORK(1/16W, 33ohm, 1005X4)	33 ohm 1/16W 5% CN24J330
R4080	CRJ10DJ472T	RES , CHIP	4K7ohm 1/16W 5% 0603
R4081	CRJ10DJ562T	RES , CHIP	5K6 ohm 1/16W 5% 0603
R4082	CRJ10DJ561T	RES , CHIP	560 ohm 1/16W 5% 0603
R4083	CRJ10DF1371T	RES , CHIP(1.37 KOHM ,1/16W,1%,1608)	1.37K ohm 1/16W 1% 0603
R4084	CRJ10DJ472T	RES , CHIP	4K7ohm 1/16W 5% 0603
R4085	CRJ10DJ562T	RES , CHIP	5K6 ohm 1/16W 5% 0603
R4086	CRJ064IJ330T	RES , CHIP NETWORK(1/16W, 33ohm, 1005X4)	33 ohm 1/16W 5% CN24J330
R4087	CRJ10DJ103T	RES , CHIP	10K ohm 1/16W 5% 0603
R4088	CRJ10DJ472T	RES , CHIP	4K7ohm 1/16W 5% 0603
R4089	CRJ10DJ561T	RES , CHIP	560 ohm 1/16W 5% 0603
R4090	CRJ064IJ330T	RES , CHIP NETWORK(1/16W, 33ohm, 1005X4)	33 ohm 1/16W 5% CN24J330
R4091	CRJ064IJ330T	RES , CHIP NETWORK(1/16W, 33ohm, 1005X4)	33 ohm 1/16W 5% CN24J330
R4092	CRJ064IJ330T	RES , CHIP NETWORK(1/16W, 33ohm, 1005X4)	33 ohm 1/16W 5% CN24J330
R4093	CRJ10DJ472T	RES , CHIP	4K7ohm 1/16W 5% 0603
R4094	CRJ10DJ561T	RES , CHIP	560 ohm 1/16W 5% 0603
R4095	CRJ10DJ472T	RES , CHIP	4K7ohm 1/16W 5% 0603
R4096	CRJ10DJ562T	RES , CHIP	5K6 ohm 1/16W 5% 0603
R4097	CRJ064IJ330T	RES , CHIP NETWORK(1/16W, 33ohm, 1005X4)	33 ohm 1/16W 5% CN24J330
R4098	CRJ064IJ330T	RES , CHIP NETWORK(1/16W, 33ohm, 1005X4)	33 ohm 1/16W 5% CN24J330
R4099	CRJ10DJ103T	RES , CHIP	10K ohm 1/16W 5% 0603
R4100	CRJ10DJ472T	RES , CHIP	4K7ohm 1/16W 5% 0603
R4101	CRJ10DJ822T	RES , CHIP	8K2 ohm 1/16W 5% 0603
R4102	CRJ10DJ561T	RES , CHIP	560 ohm 1/16W 5% 0603
R4103	CRJ10DJ472T	RES , CHIP	4K7ohm 1/16W 5% 0603
R4104	CRJ10DJ822T	RES , CHIP	8K2 ohm 1/16W 5% 0603
R4105	CRJ10DJ750T	RES , CHIP	75 ohm 1/16W 5% 0603
R4106	CRJ10DJ100T	RES , CHIP	10 ohm 1/16W 5% 0603
R4107	CRJ10DJ100T	RES , CHIP	10 ohm 1/16W 5% 0603
R4108	CRJ10DJ472T	RES , CHIP	4K7ohm 1/16W 5% 0603
R4109	CRJ10DJ561T	RES , CHIP	560 ohm 1/16W 5% 0603
R4110	CRJ10DJ472T	RES , CHIP	4K7ohm 1/16W 5% 0603
R4111	CRJ10DJ562T	RES , CHIP	5K6 ohm 1/16W 5% 0603
R4112	CRJ064IJ330T	RES , CHIP NETWORK(1/16W, 33ohm, 1005X4)	33 ohm 1/16W 5% CN24J330
R4113	CRJ064IJ330T	RES , CHIP NETWORK(1/16W, 33ohm, 1005X4)	33 ohm 1/16W 5% CN24J330
R4114	CRJ064IJ330T	RES , CHIP NETWORK(1/16W, 33ohm, 1005X4)	33 ohm 1/16W 5% CN24J330
R4115	CRJ064IJ330T	RES , CHIP NETWORK(1/16W, 33ohm, 1005X4)	33 ohm 1/16W 5% CN24J330
R4116	CRJ10DJ472T	RES , CHIP	4K7ohm 1/16W 5% 0603
R4117	CRJ10DJ562T	RES , CHIP	5K6 ohm 1/16W 5% 0603
R4118	CRJ10DJ561T	RES , CHIP	560 ohm 1/16W 5% 0603
R4119	CRJ10DJ472T	RES , CHIP	4K7ohm 1/16W 5% 0603
R4120	CRJ10DJ331T	RES , CHIP	330 ohm 1/16W 5% 0603
R4121	CRJ10DJ331T	RES , CHIP	330 ohm 1/16W 5% 0603
R4122	CRJ10DJ103T	RES , CHIP	10K ohm 1/16W 5% 0603
R4123	CRJ10DJ103T	RES , CHIP	10K ohm 1/16W 5% 0603
R4124	CRJ10DJ103T	RES , CHIP	10K ohm 1/16W 5% 0603
R4125	CRJ10DJ203T	RES , CHIP	20K ohm 1/16W 5% 0603
R4126	CRJ10DJ473T	RES , CHIP	47K ohm 1/16W 5% 0603
R4127	CRJ10DJ103T	RES , CHIP	10K ohm 1/16W 5% 0603
R4128	CRJ10DJ103T	RES , CHIP	10K ohm 1/16W 5% 0603
R4129	CRJ10DJ103T	RES , CHIP	10K ohm 1/16W 5% 0603
R4130	CRJ10DJ203T	RES , CHIP	20K ohm 1/16W 5% 0603
R4131	CRJ10DJ105T	RES , CHIP	1M ohm 1/16W 5% 0603
R4132	CRJ10DJ0R0T	RES , CHIP	0 ohm 1/16W 0% 0603
R4133	CRJ10DJ331T	RES , CHIP	330 ohm 1/16W 5% 0603
R4134	CRJ062IJ330T	RES , CHIP NETWORK(1/16W, 33ohm, 1005X2)	33 ohm 1/16W 5% CN22J330
R4135	CRJ10DJ331T	RES , CHIP	330 ohm 1/16W 5% 0603
R4136	CRJ064IJ330T	RES , CHIP NETWORK(1/16W, 33ohm, 1005X4)	33 ohm 1/16W 5% CN24J330
R4137	CRJ10DJ470T	RES , CHIP	47 ohm 1/16W 5% 0603
R4138	CRJ10DJ470T	RES , CHIP	47 ohm 1/16W 5% 0603
R4139	CRJ064IJ330T	RES , CHIP NETWORK(1/16W, 33ohm, 1005X4)	33 ohm 1/16W 5% CN24J330
R4140	CRJ10DJ470T	RES , CHIP	47 ohm 1/16W 5% 0603
R4141	CRJ10DJ432T	RES , CHIP	4K3 ohm 1/16W 5% 0603
R4142	CRJ064IJ330T	RES , CHIP NETWORK(1/16W, 33ohm, 1005X4)	33 ohm 1/16W 5% CN24J330
R4143	CRJ10DJ470T	RES , CHIP	47 ohm 1/16W 5% 0603
R4144	CRJ10DJ432T	RES , CHIP	4K3 ohm 1/16W 5% 0603
R4145	CRJ10DJ472T	RES , CHIP	4K7ohm 1/16W 5% 0603
R4146	CRJ064IJ330T	RES , CHIP NETWORK(1/16W, 33ohm, 1005X4)	33 ohm 1/16W 5% CN24J330
R4147	CRJ10DJ330T	RES , CHIP	33 ohm 1/16W 5% 0603

Ref. Designator	Part Number	Description	Qty
DSP PCB ASS'Y		COP12038B	
R4148	CRJ10DJ220T	RES , CHIP	22 ohm 1/16W 5% 0603
R4149	CRJ10DJ432T	RES , CHIP	4K3 ohm 1/16W 5% 0603
R4150	CRJ10DJ472T	RES , CHIP	4K7ohm 1/16W 5% 0603
R4151	CRJ10DJ103T	RES , CHIP	10K ohm 1/16W 5% 0603
R4152	CRJ10DJ432T	RES , CHIP	4K3 ohm 1/16W 5% 0603
R4153	CRJ064IJ330T	RES , CHIP NETWORK(1/16W, 33ohm, 1005X4)	33 ohm 1/16W 5% CN24J330
R4154	CRJ10DJ221T	RES , CHIP	220 ohm 1/16W 5% 0603
R4155	CRJ064IJ330T	RES , CHIP NETWORK(1/16W, 33ohm, 1005X4)	33 ohm 1/16W 5% CN24J330
R4156	CRJ10DJ221T	RES , CHIP	220 ohm 1/16W 5% 0603
R4157	CRJ064IJ330T	RES , CHIP NETWORK(1/16W, 33ohm, 1005X4)	33 ohm 1/16W 5% CN24J330
R4159	CRJ064IJ330T	RES , CHIP NETWORK(1/16W, 33ohm, 1005X4)	33 ohm 1/16W 5% CN24J330
R4160	CRJ064IJ330T	RES , CHIP NETWORK(1/16W, 33ohm, 1005X4)	33 ohm 1/16W 5% CN24J330
R4161	CRJ064IJ330T	RES , CHIP NETWORK(1/16W, 33ohm, 1005X4)	33 ohm 1/16W 5% CN24J330
R4162	CRJ064IJ330T	RES , CHIP NETWORK(1/16W, 33ohm, 1005X4)	33 ohm 1/16W 5% CN24J330
R4163	CRJ10DJ432T	RES , CHIP	4K3 ohm 1/16W 5% 0603
R4164	CRJ10DJ100T	RES , CHIP	10 ohm 1/16W 5% 0603
R4165	CRJ10DJ100T	RES , CHIP	10 ohm 1/16W 5% 0603
R4166	CRJ10DJ122T	RES , CHIP	1K2 ohm 1/16W 5% 0603
R4167	CRJ10DJ100T	RES , CHIP	10 ohm 1/16W 5% 0603
R4168	CRJ10DJ100T	RES , CHIP	10 ohm 1/16W 5% 0603
R4169	CRJ10DJ122T	RES , CHIP	1K2 ohm 1/16W 5% 0603
R4170	CRJ10DJ470T	RES , CHIP	47 ohm 1/16W 5% 0603
R4171	CRJ10DJ432T	RES , CHIP	4K3 ohm 1/16W 5% 0603
R4172	CRJ10DJ470T	RES , CHIP	47 ohm 1/16W 5% 0603
R4173	CRJ10DJ470T	RES , CHIP	47 ohm 1/16W 5% 0603
R4174	CRJ10DJ470T	RES , CHIP	47 ohm 1/16W 5% 0603
R4178	CRJ10DJ102T	RES , CHIP	1K ohm 1/16W 5% 0603
R4181	CRJ10DJ102T	RES , CHIP	1K ohm 1/16W 5% 0603
R4182	CRJ10DJ104T	RES , CHIP	100K ohm 1/16W 5% 0603
R4183	CRJ10DJ102T	RES , CHIP	1K ohm 1/16W 5% 0603
R4185	CRJ10DJ102T	RES , CHIP	1K ohm 1/16W 5% 0603
R4186	CRJ10DJ102T	RES , CHIP	1K ohm 1/16W 5% 0603
R4187	CRJ10DJ102T	RES , CHIP	1K ohm 1/16W 5% 0603
R4188	CRJ10DJ432T	RES , CHIP	4K3 ohm 1/16W 5% 0603
R4189	CRJ10DJ202T	RES , CHIP	2K ohm 1/16W 5% 0603
R4190	CRJ10DJ432T	RES , CHIP	4K3 ohm 1/16W 5% 0603
R4191	CRJ10DJ202T	RES , CHIP	2K ohm 1/16W 5% 0603
R4192	CRJ10DJ202T	RES , CHIP	2K ohm 1/16W 5% 0603
R4193	CRJ10DJ102T	RES , CHIP	1K ohm 1/16W 5% 0603
R4195	CRJ10DJ432T	RES , CHIP	4K3 ohm 1/16W 5% 0603
R4196	CRJ10DJ202T	RES , CHIP	2K ohm 1/16W 5% 0603
R4199	CRJ10DJ432T	RES , CHIP	4K3 ohm 1/16W 5% 0603
R4200	CRJ10DJ221T	RES , CHIP	220 ohm 1/16W 5% 0603
R4201	CRJ10DJ221T	RES , CHIP	220 ohm 1/16W 5% 0603
R4202	CRJ10DJ472T	RES , CHIP	4K7ohm 1/16W 5% 0603
R4203	CRJ18AJ101T	RES , CHIP	100 ohm 1/10W 5% 0805
R4204	CRJ10DJ0R0T	RES , CHIP	0 ohm 1/16W 0% 0603
R4205	CRJ10DJ471T	RES , CHIP	470 ohm 1/16W 5% 0603
R4207	CRJ10DJ473T	RES , CHIP	47K ohm 1/16W 5% 0603
R4208	CRJ10DJ102T	RES , CHIP	1K ohm 1/16W 5% 0603
R4209	CRJ10DJ473T	RES , CHIP	47K ohm 1/16W 5% 0603
R4210	CRJ10DJ101T	RES , CHIP	100 ohm 1/16W 5% 0603
R4211	CRJ10DJ101T	RES , CHIP	100 ohm 1/16W 5% 0603
R4212	CRJ10DJ470T	RES , CHIP	47 ohm 1/16W 5% 0603
R4213	CRJ10DJ101T	RES , CHIP	100 ohm 1/16W 5% 0603
R4214	CRJ10DJ103T	RES , CHIP	10K ohm 1/16W 5% 0603
R4215	CRJ10DJ103T	RES , CHIP	10K ohm 1/16W 5% 0603
R4227	CRJ10DJ102T	RES , CHIP	1K ohm 1/16W 5% 0603
R4229	CRJ10DJ101T	RES , CHIP	100 ohm 1/16W 5% 0603
R4235	CRJ10DJ101T	RES , CHIP	100 ohm 1/16W 5% 0603
R4276	CRJ10DJ271T	RES , CHIP	270 ohm 1/16W 5% 0603
R4277	CRJ10DJ0R0T	RES , CHIP	0 ohm 1/16W 0% 0603
R4278	CRJ10DJ101T	RES , CHIP	100 ohm 1/16W 5% 0603
R4401	CRJ062IJ330T	RES , CHIP NETWORK(1/16W, 33ohm, 1005X2)	33 ohm 1/16W 5% CN22J330
R4415	CRJ10DJ331T	RES , CHIP	330 ohm 1/16W 5% 0603
R4416	CRJ10DJ331T	RES , CHIP	330 ohm 1/16W 5% 0603
R4417	CRJ10DJ331T	RES , CHIP	330 ohm 1/16W 5% 0603
R4509	CRJ064IJ330T	RES , CHIP NETWORK(1/16W, 33ohm, 1005X4)	33 ohm 1/16W 5% CN24J330
R4572	CRJ10DJ102T	RES , CHIP	1K ohm 1/16W 5% 0603
R4573	CRJ10DJ102T	RES , CHIP	1K ohm 1/16W 5% 0603
R4587	CRJ10DJ471T	RES , CHIP	470 ohm 1/16W 5% 0603

Ref. Designator	Part Number	Description		Qty
DSP PCB ASS'Y		COP12038B		
R4588	CRJ10DJ471T	RES , CHIP	470 ohm 1/16W 5% 0603	1
R4590	CRJ10DJ221T	RES , CHIP	220 ohm 1/16W 5% 0603	1
<i>Miscellaneous</i>				
BD4000	CLZ9R012Z	BEAD , FERRITE(FCM2012CF-301T04 300ohm)		1
BD4003	CLZ9R012Z	BEAD , FERRITE(FCM2012CF-301T04 300ohm)		1
BD4004	CLZ9R012Z	BEAD , FERRITE(FCM2012CF-301T04 300ohm)		1
BD4006	CLZ9R012Z	BEAD , FERRITE(FCM2012CF-301T04 300ohm)		1
BD4007	CLZ9R012Z	BEAD , FERRITE(FCM2012CF-301T04 300ohm)		1
BD4008	CLZ9R012Z	BEAD , FERRITE(FCM2012CF-301T04 300ohm)		1
BD4010	CLZ9R013Z	BEAD , FERRITE(HCB2012KF-151T20 150ohm)		1
BD4011	CLZ9R012Z	BEAD , FERRITE(FCM2012CF-301T04 300ohm)		1
BD4013	CLZ9R013Z	BEAD , FERRITE(HCB2012KF-151T20 150ohm)		1
BD4015	CLZ9R012Z	BEAD , FERRITE(FCM2012CF-301T04 300ohm)		1
BD4029	CLZ9R012Z	BEAD , FERRITE(FCM2012CF-301T04 300ohm)		1
BD4001	CLZ9R012Z	BEAD , FERRITE(FCM2012CF-301T04 300ohm)	FCM2012CF-301T04 0805	1
BD4012	CLZ9R012Z	BEAD , FERRITE(FCM2012CF-301T04 300ohm)	FCM2012CF-301T04 0805	1
BD4014	CLZ9R010Z	BEAD , FERRITE (FCM2012KF-121T08 , 120 OHM)	FCM2012KF-121T08 120ohm 2012	1
BD4016	CLZ9R010Z	BEAD , FERRITE (FCM2012KF-121T08 , 120 OHM)	FCM2012KF-121T08 120ohm 2012	1
BD4017	CLZ91002Z	FERRITE , CHIP BEAD(120ohm, 3216)	HCB3216KF-121T50	1
BD4020	CLZ9R012Z	BEAD , FERRITE(FCM2012CF-301T04 300ohm)	FCM2012CF-301T04 0805	1
BD4021	CLZ9R012Z	BEAD , FERRITE(FCM2012CF-301T04 300ohm)	FCM2012CF-301T04 0805	1
BD4022	CLZ9R010Z	BEAD , FERRITE (FCM2012KF-121T08 , 120 OHM)	FCM2012KF-121T08 120ohm 2012	1
BD4023	CLZ9R012Z	BEAD , FERRITE(FCM2012CF-301T04 300ohm)	FCM2012CF-301T04 0805	1
BD4025	CLZ9R012Z	BEAD , FERRITE(FCM2012CF-301T04 300ohm)	FCM2012CF-301T04 0805	1
BD4030	CLZ9R012Z	BEAD , FERRITE(FCM2012CF-301T04 300ohm)	FCM2012CF-301T04 0805	1
BD4031	CLZ9R012Z	BEAD , FERRITE(FCM2012CF-301T04 300ohm)	FCM2012CF-301T04 0805	1
BD4032	CLZ9R012Z	BEAD , FERRITE(FCM2012CF-301T04 300ohm)	FCM2012CF-301T04 0805	1
BD4033	CLZ9R012Z	BEAD , FERRITE(FCM2012CF-301T04 300ohm)	FCM2012CF-301T04 0805	1
BD4034	CLZ9R012Z	BEAD , FERRITE(FCM2012CF-301T04 300ohm)	FCM2012CF-301T04 0805	1
BD4035	CLZ9R012Z	BEAD , FERRITE(FCM2012CF-301T04 300ohm)	FCM2012CF-301T04 0805	1
BD4036	CLZ9R012Z	BEAD , FERRITE(FCM2012CF-301T04 300ohm)	FCM2012CF-301T04 0805	1
BD4037	CLZ9R012Z	BEAD , FERRITE(FCM2012CF-301T04 300ohm)	FCM2012CF-301T04 0805	1
BD4038	CLZ9R012Z	BEAD , FERRITE(FCM2012CF-301T04 300ohm)	FCM2012CF-301T04 0805	1
BD4039	CLZ9R012Z	BEAD , FERRITE(FCM2012CF-301T04 300ohm)	FCM2012CF-301T04 0805	1
BD4040	CLZ9R012Z	BEAD , FERRITE(FCM2012CF-301T04 300ohm)	FCM2012CF-301T04 0805	1
BD4041	CLZ9R012Z	BEAD , FERRITE(FCM2012CF-301T04 300ohm)	FCM2012CF-301T04 0805	1
BD4042	CLZ9R012Z	BEAD , FERRITE(FCM2012CF-301T04 300ohm)	FCM2012CF-301T04 0805	1
BD4043	CLZ9R012Z	BEAD , FERRITE(FCM2012CF-301T04 300ohm)	FCM2012CF-301T04 0805	1
BD4044	CLZ9R012Z	BEAD , FERRITE(FCM2012CF-301T04 300ohm)	FCM2012CF-301T04 0805	1
BD4045	CLZ9R012Z	BEAD , FERRITE(FCM2012CF-301T04 300ohm)	FCM2012CF-301T04 0805	1
BD4046	CLZ9R012Z	BEAD , FERRITE(FCM2012CF-301T04 300ohm)	FCM2012CF-301T04 0805	1
BD4047	CLZ9R012Z	BEAD , FERRITE(FCM2012CF-301T04 300ohm)	FCM2012CF-301T04 0805	1
BD4048	CLZ9R012Z	BEAD , FERRITE(FCM2012CF-301T04 300ohm)	FCM2012CF-301T04 0805	1
BD4049	CLZ9R012Z	BEAD , FERRITE(FCM2012CF-301T04 300ohm)	FCM2012CF-301T04 0805	1
BD4050	CLZ9R012Z	BEAD , FERRITE(FCM2012CF-301T04 300ohm)	FCM2012CF-301T04 0805	1
L4005	CLQ10E100MRY	COIL , CHIP(10UH, 3226)	MIP3226D100M	1
L4006	CLQ10E100MRY	COIL , CHIP(10UH, 3226)	MIP3226D100M	1
Y4000	COX45158I220SCS	OSC (45.1584MHZ, 22PF, 20 PPM, -20~85)	SO22320G545.158GR	1
Y4001	COX24576C150SC	OSC (24.576MHZ,5x7 SMD,3.3V Reel)	WIN24576OSCS573	1
HK4001	HJT1A025	PLATE , EARTH	MET37-0002	1
L4000	CLQ03D470JT	COIL , RADIAL (47UH, 5%, 2.7 OHM, 192mA, 5.0MM)	EL0606RA-470J-PF , TDK	1
L4001	CLQ03D470JT	COIL , RADIAL (47UH, 5%, 2.7 OHM, 192mA, 5.0MM)	EL0606RA-470J-PF , TDK	1
L4002	CLQ03D470JT	COIL , RADIAL (47UH, 5%, 2.7 OHM, 192mA, 5.0MM)	EL0606RA-470J-PF , TDK	1
L4003	CLQ03D470JT	COIL , RADIAL (47UH, 5%, 2.7 OHM, 192mA, 5.0MM)	EL0606RA-470J-PF , TDK	1
L4004	CLQ03D470JT	COIL , RADIAL (47UH, 5%, 2.7 OHM, 192mA, 5.0MM)	EL0606RA-470J-PF , TDK	1
Y4002	COX24576E180TF	CRYSTAL , 24.576MHz	CRYSTAL_HC-49/S_18PF	1
Y4003	CVFCSTLS5M00G56A0	RESONATOR , CERAMIC(5.0MHz 56PF)	CSTLS_G 5.0MHz	1
HK4000	CMD1A661	BRACKET , XM AVBR755		1
JA4000	CJJ9L006Z	JACK , XM	CAM-D96	1
JA4001	CJS9U011Z	JACK, OPTICAL+COXIAL(GOLD PLATE)	YKC22-0872V	1
JA4002	CJS9U016Z	JACK , OPT + 1P RCA (RX 5V YKC22-0873V AU PLATE)	YKC22-0873V, RX , JALCO	1
JA4003	CJS9U016Z	JACK , OPT + 1P RCA (RX 5V YKC22-0873V AU PLATE)	YKC22-0873V, RX , JALCO	1
JA4004	CJS9U016Z	JACK , OPT + 1P RCA (RX 5V YKC22-0873V AU PLATE)	YKC22-0873V, RX , JALCO	1
JA4005	CJJ4P063Z	JACK , RCA (4P, 401DAG, GN BN PP TA, AU PL)	RCA-401DAG-18 (RCA 2x2)	1
JA4006	CJJ4P055Z	JACK 4P WH/BL/RD/GY	RCA-401DAG-16 WH/BL/RD/GY	1
N4001	CJP19GB99ZM	WAFER(19P, AN 2MM)	35237-1910 2.0mm 19P WHT	1
N4002	CJP17GA115ZY	WAFER , CARDCABLE	GF120-17S-TS 1.25mm 17P	1
N4003	CJP11GA115ZY	WAFER(11P, ST 1.25MM)	GF120-11S-TS 1.25mm 11P	1
N4005	CJP19GB99ZM	WAFER(19P, AN 2MM)	35237-1910 2.0mm 19P WHT	1

Ref. Designator	Part Number	Description		Qty
DSP PCB ASS'Y		COP12038B		
N4006	CJP19GB99ZM	WAFER(19P, AN 2MM)	35237-1910 2.0mm 19P WHT	1
N4007	CJP10GB99ZY	WAFER	35237-1010 2.0mm 10P WHT	1
N4009	CJP07GA01ZY	WAFER , STRAIGHT(7PIN)	5267-07A 2.5mm 7P WHT	1
N4010	CJP21GA115ZY	WAFER , CARD CABLE	GF120-21S-TS 1.25mm 21P	1
N4011	CJP16GB99ZM	WAFER(16P, AN 2MM)	35237-1610 2.0mm 16P WHT	1
P4000	CJP05GA47ZW	WAFER,2mm	GIL-S-5P-S2T2-EF 5P	1
P4001	CJP10GA98ZY	WAFER	35336-1010 2.0mm 10P WHT	1
P4004	CJP09GA47ZW	CNT , WAFER	GIL-S-9P-S2T2-EF 9P	1
P4011	CJP29GA115ZY	WAFER , CARD CABLE(1.25MM, STRAIGHT)	YEONHO 12511 SERIES	1
Ethernet PCB ASS'Y		COP12039B		1
<i>Capacitors</i>				
C5024	CCUS1H104KC	CAP , CHIP	0.1UF 50V K	1
C5025	CCSJB1A220B	CAP , CHIP TANTAL(B TYPE, 22uF/10V, ELNA)		1
C5026	CCUS1H104KC	CAP , CHIP	0.1UF 50V K	1
C5027	CCUS1H104KC	CAP , CHIP	0.1UF 50V K	1
C5028	CCUS1H104KC	CAP , CHIP	0.1UF 50V K	1
C5029	CCUS1H100JA	CAP , CHIP	10PF 50V J	1
C5030	CCUS1H104KC	CAP , CHIP	0.1UF 50V K	1
C5031	CCUS1H104KC	CAP , CHIP	0.1UF 50V K	1
C5032	CCUS1H104KC	CAP , CHIP	0.1UF 50V K	1
C5033	CCSJA1C100B	CAP , CHIP TANTAL(A TYPE, 10uF/16V, ELNA)	10uF/16V	1
C5034	CCSJA1C100B	CAP , CHIP TANTAL(A TYPE, 10uF/16V, ELNA)	10uF/16V	1
C5035	CCUS1H100JA	CAP , CHIP	10PF 50V J	1
C5036	CCUS1H100JA	CAP , CHIP	10PF 50V J	1
C5037	CCUS1H100JA	CAP , CHIP	10PF 50V J	1
C5038	CCUS1H100JA	CAP , CHIP	10PF 50V J	1
C5039	CCUS1H104KC	CAP , CHIP	0.1UF 50V K	1
C5040	CCUS1H104KC	CAP , CHIP	0.1UF 50V K	1
C5041	CCUS1H104KC	CAP , CHIP	0.1UF 50V K	1
C5042	CCUS1H104KC	CAP , CHIP	0.1UF 50V K	1
C5043	CCUS1H104KC	CAP , CHIP	0.1UF 50V K	1
C5044	CCUS1H104KC	CAP , CHIP	0.1UF 50V K	1
C5045	CCUS1H104KC	CAP , CHIP	0.1UF 50V K	1
C5046	CCUS1H104KC	CAP , CHIP	0.1UF 50V K	1
C5047	CCUS1H104KC	CAP , CHIP	0.1UF 50V K	1
C5048	CCUS1H104KC	CAP , CHIP	0.1UF 50V K	1
C5049	CCUS1H104KC	CAP , CHIP	0.1UF 50V K	1
C5050	CCUS1H104KC	CAP , CHIP	0.1UF 50V K	1
C5051	CCSJB1A220B	CAP , CHIP TANTAL(B TYPE, 22uF/10V, ELNA)	22uF/10V	1
C5052	CCUS1H104KC	CAP , CHIP	0.1UF 50V K	1
C5053	CCUS1H104KC	CAP , CHIP	0.1UF 50V K	1
C5055	CCUS1H104KC	CAP , CHIP	0.1UF 50V K	1
C5056	CCUS1H100JA	CAP , CHIP	10PF 50V J	1
C5057	CCUS1H104KC	CAP , CHIP	0.1UF 50V K	1
C5058	CCUS1H104KC	CAP , CHIP	0.1UF 50V K	1
C5059	CCUS1H104KC	CAP , CHIP	0.1UF 50V K	1
C5060	CCUS1H102KC	CAP , CHIP	1000PF 50V K	1
C5061	CCUS1H104KC	CAP , CHIP	0.1UF 50V K	1
C5062	CCUS1H100JA	CAP , CHIP	10PF 50V J	1
C5063	CCUS1H104KC	CAP , CHIP	0.1UF 50V K	1
C5064	CCUS1H104KC	CAP , CHIP	0.1UF 50V K	1
C5065	CCUC0J106KC	CAP , CHIP (10UF/6.3V K X5R 2012)	10UF/6.3V	1
C5066	CCUS1H104KC	CAP , CHIP	0.1UF 50V K	1
C5067	CCUS1H104KC	CAP , CHIP	0.1UF 50V K	1
C5068	CCUS1H104KC	CAP , CHIP	0.1UF 50V K	1
C5069	CCUS1H104KC	CAP , CHIP	0.1UF 50V K	1
C5070	CCUS1H104KC	CAP , CHIP	0.1UF 50V K	1
C5071	CCUS1H104KC	CAP , CHIP	0.1UF 50V K	1
C5072	CCUS1H104KC	CAP , CHIP	0.1UF 50V K	1
C5073	CCUC0J106KC	CAP , CHIP (10UF/6.3V K X5R 2012)		1
C5074	CCUS1H100JA	CAP , CHIP	10PF 50V J	1
C5075	CCUC0J106KC	CAP , CHIP (10UF/6.3V K X5R 2012)		1
C5076	CCUS1H104KC	CAP , CHIP	0.1UF 50V K	1
C5077	CCUS1H100JA	CAP , CHIP	10PF 50V J	1
C5078	CCUS1H100JA	CAP , CHIP	10PF 50V J	1
C5079	CCUS1H100JA	CAP , CHIP	10PF 50V J	1
C5080	CCUS1H100JA	CAP , CHIP	10PF 50V J	1
C5081	CCUS1H104KC	CAP , CHIP	0.1UF 50V K	1

Ref. Designator	Part Number	Description		Qty
Ethernet PCB ASS'Y		COP12039B		
C5082	CCUS1H104KC	CAP , CHIP	0.1UF 50V K	1
C5083	CCSJB1A220B	CAP , CHIP TANTAL(B TYPE, 22uF/10V, ELNA)	22uF/10V	1
C5084	CCSJB1A220B	CAP , CHIP TANTAL(B TYPE, 22uF/10V, ELNA)	22uF/10V	1
C5085	CCUC0J106KC	CAP , CHIP (10UF/6.3V K X5R 2012)	10UF/6.3V	1
C5086	CCUS1H104KC	CAP , CHIP	0.1UF 50V K	1
C5087	CCUS1H104KC	CAP , CHIP	0.1UF 50V K	1
C5088	CCUS1H104KC	CAP , CHIP	0.1UF 50V K	1
C5003	CCUS1H104KC	CAP , CHIP	0.1UF 50V K	1
C5004	CCUS1H104KC	CAP , CHIP	0.1UF 50V K	1
C5005	CCUS1H104KC	CAP , CHIP	0.1UF 50V K	1
C5008	CCUS1H104KC	CAP , CHIP	0.1UF 50V K	1
C5013	CCUS1H100JA	CAP , CHIP	10PF 50V J	1
C5014	CCUS1H330JA	CAP , CHIP	33PF 50V J	1
C5016	CCUS1H330JA	CAP , CHIP	33PF 50V J	1
C5017	CCUS1H100JA	CAP , CHIP	10PF 50V J	1
C5019	CCUS1H104KC	CAP , CHIP	0.1UF 50V K	1
C5020	CCSJA1C100B	CAP , CHIP TANTAL(A TYPE, 10uF/16V, ELNA)	10uF 16V T491B106M016AS 3528	1
C5021	CCUS1H100JA	CAP , CHIP	10PF 50V J	1
C5022	CCUS1H100JA	CAP , CHIP	10PF 50V J	1
C5023	CCSJA1C100B	CAP , CHIP TANTAL(A TYPE, 10uF/16V, ELNA)	10uF 16V T491B106M016AS 3528	1
C5089	CCUS1H560JA	CAP , CHIP	56PF 50V J	1
C5018	CCEA1CH471T	CAP , ELECT	470UF 16V	1
C5000	CCUVJ3A102MCT	CAP , CERAMIC (EFI 1KV 1000PF M X7R 2000VDC 3216)	VJ1206Y102MBFAT , VISHAY(AVN)	1
<i>Semiconductors</i>				
Q5001	HVTKTC3875SYRTK	TRANSISTOR , CHIP	KTC3875S Y RTK	1
IC5000	CVIS29GL064N90TFI0	I.C , FLASH 64M (FAGE MODE,TSOP-48P)	S29GL064N90TFI060 64M 48TSOP1	1
IC5001	CVIM12L128168A-6TG	I.C , SDRAM	M12L128168A-6TG , ESMT(ADS)	1
IC5002	CVIDM9161AEP	I.C , Ethernet PHY Transceiver,LQFP48	DM9161AEP LQFP48	1
IC5004	CVIDM850E-CQ	I.C , DM850E M.N.PROCESSOR LPFQ-208	DM850E LPFQ 208	1
IC5005	HVILM1117S-1V8	I.C , REGULATOR (1.8V)	LM1117-1V8	1
Q5000	CVTKMA2D3P20SRTKP	F.E.T , P-CH MOS	KMA2D3P20S-RTK/P, KEC	1
<i>Resistors</i>				
R5076	CRJ104DJ220T	RES,4ARRAY	22X4/2012	1
R5077	CRJ104DJ220T	RES,4ARRAY	22X4/2012	1
R5079	CRJ10DJ0R0T	RES , CHIP	0 ohm 1/16W 0% 0603	1
R5080	CRJ104DJ220T	RES,4ARRAY	22X4/2012	1
R5081	CRJ10DJ472T	RES , CHIP	4K7ohm 1/16W 5% 0603	1
R5083	CRJ104DJ220T	RES,4ARRAY	22X4/2012	1
R5084	CRJ10DJ0R0T	RES , CHIP	0 ohm 1/16W 0% 0603	1
R5085	CRJ10DJ472T	RES , CHIP	4K7ohm 1/16W 5% 0603	1
R5086	CRJ10DJ472T	RES , CHIP	4K7ohm 1/16W 5% 0603	1
R5087	CRJ10DF56R2T	RES. CHIP (56.2 OHM 1%)	56.2 ohm 1/16W 1% 0603	1
R5088	CRJ10DJ103T	RES , CHIP	10K ohm 1/16W 5% 0603	1
R5089	CRJ10DJ103T	RES , CHIP	10K ohm 1/16W 5% 0603	1
R5090	CRJ10DJ472T	RES , CHIP	4K7ohm 1/16W 5% 0603	1
R5091	CRJ10DJ472T	RES , CHIP	4K7ohm 1/16W 5% 0603	1
R5092	CRJ10DJ472T	RES , CHIP	4K7ohm 1/16W 5% 0603	1
R5093	CRJ10DJ103T	RES , CHIP	10K ohm 1/16W 5% 0603	1
R5094	CRJ10DJ472T	RES , CHIP	4K7ohm 1/16W 5% 0603	1
R5095	CRJ10DJ301T	RES , CHIP	300 ohm 1/16W 5% 0603	1
R5096	CRJ10DJ301T	RES , CHIP	300 ohm 1/16W 5% 0603	1
R5097	CRJ10DJ103T	RES , CHIP	10K ohm 1/16W 5% 0603	1
R5098	CRJ10DJ473T	RES , CHIP	47K ohm 1/16W 5% 0603	1
R5099	CRJ10DJ510T	RES , CHIP	51 ohm 1/16W 5% 0603	1
R5100	CRJ10DJ301T	RES , CHIP	300 ohm 1/16W 5% 0603	1
R5101	CRJ10DJ103T	RES , CHIP	10K ohm 1/16W 5% 0603	1
R5102	CRJ10DJ473T	RES , CHIP	47K ohm 1/16W 5% 0603	1
R5103	CRJ10DJ510T	RES , CHIP	51 ohm 1/16W 5% 0603	1
R5104	CRJ10DJ301T	RES , CHIP	300 ohm 1/16W 5% 0603	1
R5105	CRJ10DJ473T	RES , CHIP	47K ohm 1/16W 5% 0603	1
R5106	CRJ10DJ152T	RES , CHIP	1K5 ohm 1/16W 5% 0603	1
R5107	CRJ10DJ473T	RES , CHIP	47K ohm 1/16W 5% 0603	1
R5108	CRJ10DJ0R0T	RES , CHIP	0 ohm 1/16W 0% 0603	1
R5109	CRJ10DJ473T	RES , CHIP	47K ohm 1/16W 5% 0603	1
R5110	CRJ10DJ0R0T	RES , CHIP	0 ohm 1/16W 0% 0603	1
R5111	CRJ10DJ472T	RES , CHIP	4K7ohm 1/16W 5% 0603	1
R5112	CRJ10DJ473T	RES , CHIP	47K ohm 1/16W 5% 0603	1

Ref. Designator	Part Number	Description	Qty
Ethernet PCB ASS'Y		COP12039B	
R5113	CRJ10DJ473T	RES , CHIP	47K ohm 1/16W 5% 0603
R5114	CRJ10DJ473T	RES , CHIP	47K ohm 1/16W 5% 0603
R5115	CRJ10DJ510T	RES , CHIP	51 ohm 1/16W 5% 0603
R5116	CRJ10DJ473T	RES , CHIP	47K ohm 1/16W 5% 0603
R5117	CRJ10DJ473T	RES , CHIP	47K ohm 1/16W 5% 0603
R5118	CRJ10DJ473T	RES , CHIP	47K ohm 1/16W 5% 0603
R5119	CRJ10DJ473T	RES , CHIP	47K ohm 1/16W 5% 0603
R5120	CRJ10DJ473T	RES , CHIP	47K ohm 1/16W 5% 0603
R5121	CRJ10DJ473T	RES , CHIP	47K ohm 1/16W 5% 0603
R5122	CRJ10DJ473T	RES , CHIP	47K ohm 1/16W 5% 0603
R5123	CRJ10DJ473T	RES , CHIP	47K ohm 1/16W 5% 0603
R5124	CRJ10DJ473T	RES , CHIP	47K ohm 1/16W 5% 0603
R5125	CRJ10DJ510T	RES , CHIP	51 ohm 1/16W 5% 0603
R5126	CRJ10DJ473T	RES , CHIP	47K ohm 1/16W 5% 0603
R5127	CRJ10DJ473T	RES , CHIP	47K ohm 1/16W 5% 0603
R5128	CRJ10DJ473T	RES , CHIP	47K ohm 1/16W 5% 0603
R5129	CRJ10DJ473T	RES , CHIP	47K ohm 1/16W 5% 0603
R5130	CRJ10DJ473T	RES , CHIP	47K ohm 1/16W 5% 0603
R5131	CRJ10DJ473T	RES , CHIP	47K ohm 1/16W 5% 0603
R5132	CRJ10DJ473T	RES , CHIP	47K ohm 1/16W 5% 0603
R5133	CRJ10DJ473T	RES , CHIP	47K ohm 1/16W 5% 0603
R5134	CRJ10DJ473T	RES , CHIP	47K ohm 1/16W 5% 0603
R5135	CRJ10DJ473T	RES , CHIP	47K ohm 1/16W 5% 0603
R5136	CRJ10DJ473T	RES , CHIP	47K ohm 1/16W 5% 0603
R5137	CRJ10DJ473T	RES , CHIP	47K ohm 1/16W 5% 0603
R5138	CRJ10DJ473T	RES , CHIP	47K ohm 1/16W 5% 0603
R5139	CRJ10DJ473T	RES , CHIP	47K ohm 1/16W 5% 0603
R5140	CRJ10DJ473T	RES , CHIP	47K ohm 1/16W 5% 0603
R5141	CRJ10DJ332T	RES , CHIP	3K3 ohm 1/16W 5% 0603
R5142	CRJ10DJ202T	RES , CHIP	2K ohm 1/16W 5% 0603
R5143	CRJ10DJ0R0T	RES , CHIP	0 ohm 1/16W 0% 0603
R5144	CRJ10DJ473T	RES , CHIP	47K ohm 1/16W 5% 0603
R5145	CRJ10DJ473T	RES , CHIP	47K ohm 1/16W 5% 0603
R5146	CRJ10DJ103T	RES , CHIP	10K ohm 1/16W 5% 0603
R5147	CRJ10DF56R2T	RES , CHIP (56.2 OHM 1%)	56.2 ohm 1/16W 1% 0603
R5148	CRJ10DJ104T	RES , CHIP	100K ohm 1/16W 5% 0603
R5000	CRJ10DF75R0T	RES , CHIP 1% 75 OHM	75 OHM, 1%
R5001	CRJ10DF75R0T	RES , CHIP 1% 75 OHM	75 OHM, 1%
R5002	CRJ10DF75R0T	RES , CHIP 1% 75 OHM	75 OHM, 1%
R5003	CRJ10DF75R0T	RES , CHIP 1% 75 OHM	75 OHM, 1%
R5004	CRJ10DJ472T	RES , CHIP	4K7ohm 1/16W 5% 0603
R5005	CRJ10DJ510T	RES , CHIP	51 ohm 1/16W 5% 0603
R5006	CRJ10DJ510T	RES , CHIP	51 ohm 1/16W 5% 0603
R5007	CRJ10DJ472T	RES , CHIP	4K7ohm 1/16W 5% 0603
R5008	CRJ10DJ510T	RES , CHIP	51 ohm 1/16W 5% 0603
R5009	CRJ10DJ510T	RES , CHIP	51 ohm 1/16W 5% 0603
R5010	CRJ10DJ473T	RES , CHIP	47K ohm 1/16W 5% 0603
R5011	CRJ10DJ473T	RES , CHIP	47K ohm 1/16W 5% 0603
R5012	CRJ10DJ473T	RES , CHIP	47K ohm 1/16W 5% 0603
R5014	CRJ10DJ473T	RES , CHIP	47K ohm 1/16W 5% 0603
R5015	CRJ10DJ622T	RES , CHIP	6K2 ohm 1/16W 5% 0603
R5017	CRJ064IJ220T	RES , CHIP ARRAY	22 OHM 5% 1/16W 1005 X 4
R5018	CRJ064IJ220T	RES , CHIP ARRAY	22 OHM 5% 1/16W 1005 X 4
R5019	CRJ064IJ220T	RES , CHIP ARRAY	22 OHM 5% 1/16W 1005 X 4
R5020	CRJ064IJ220T	RES , CHIP ARRAY	22 OHM 5% 1/16W 1005 X 4
R5021	CRJ064IJ220T	RES , CHIP ARRAY	22 OHM 5% 1/16W 1005 X 4
R5022	CRJ064IJ220T	RES , CHIP ARRAY	22 OHM 5% 1/16W 1005 X 4
R5023	CRJ10DJ220T	RES , CHIP	22 ohm 1/16W 5% 0603
R5024	CRJ10DJ220T	RES , CHIP	22 ohm 1/16W 5% 0603
R5025	CRJ10DJ220T	RES , CHIP	22 ohm 1/16W 5% 0603
R5027	CRJ064IJ220T	RES , CHIP ARRAY	22 OHM 5% 1/16W 1005 X 4
R5028	CRJ10DJ473T	RES , CHIP	47K ohm 1/16W 5% 0603
R5029	CRJ10DF56R2T	RES , CHIP (56.2 OHM 1%)	56.2 ohm 1/16W 1% 0603
R5030	CRJ10DJ473T	RES , CHIP	47K ohm 1/16W 5% 0603
R5031	CRJ10DJ473T	RES , CHIP	47K ohm 1/16W 5% 0603
R5032	CRJ10DJ473T	RES , CHIP	47K ohm 1/16W 5% 0603
R5033	CRJ10DJ473T	RES , CHIP	47K ohm 1/16W 5% 0603
R5034	CRJ10DJ473T	RES , CHIP	47K ohm 1/16W 5% 0603
R5036	CRJ064IJ220T	RES , CHIP ARRAY	22 OHM 5% 1/16W 1005 X 4
R5037	CRJ10DJ103T	RES , CHIP	10K ohm 1/16W 5% 0603
R5039	CRJ064IJ220T	RES , CHIP ARRAY	22 OHM 5% 1/16W 1005 X 4

Ref. Designator	Part Number	Description	Qty
Ethernet PCB ASS'Y		COP12039B	
R5040	CRJ064IJ220T	RES , CHIP ARRAY	22 OHM 5% 1/16W 1005 X 4
R5041	CRJ10DJ103T	RES , CHIP	10K ohm 1/16W 5% 0603
R5042	CRJ10DJ103T	RES , CHIP	10K ohm 1/16W 5% 0603
R5043	CRJ10DJ103T	RES , CHIP	10K ohm 1/16W 5% 0603
R5044	CRJ10DJ103T	RES , CHIP	10K ohm 1/16W 5% 0603
R5045	CRJ10DJ473T	RES , CHIP	47K ohm 1/16W 5% 0603
R5046	CRJ10DJ103T	RES , CHIP	10K ohm 1/16W 5% 0603
R5047	CRJ10DJ394T	RES , CHIP (390K OHM , 5% , 1608)	390K ohm 1/10W 5% 0603
R5048	CRJ10DJ103T	RES , CHIP	10K ohm 1/16W 5% 0603
R5049	CRJ10DJ471T	RES , CHIP	470 ohm 1/16W 5% 0603
R5050	CRJ10DJ103T	RES , CHIP	10K ohm 1/16W 5% 0603
R5051	CRJ10DJ102T	RES , CHIP	1K ohm 1/16W 5% 0603
R5052	CRJ10DJ472T	RES , CHIP	4K7ohm 1/16W 5% 0603
R5053	CRJ10DJ473T	RES , CHIP	47K ohm 1/16W 5% 0603
R5054	CRJ10DF56R2T	RES. CHIP (56.2 OHM 1%)	56.2 ohm 1/16W 1% 0603
R5055	CRJ10DJ301T	RES , CHIP	300 ohm 1/16W 5% 0603
R5056	CRJ10DJ301T	RES , CHIP	300 ohm 1/16W 5% 0603
R5057	CRJ10DJ301T	RES , CHIP	300 ohm 1/16W 5% 0603
R5058	CRJ10DJ301T	RES , CHIP	300 ohm 1/16W 5% 0603
R5059	CRJ10DJ473T	RES , CHIP	47K ohm 1/16W 5% 0603
R5060	CRJ10DJ473T	RES , CHIP	47K ohm 1/16W 5% 0603
R5061	CRJ10DF56R2T	RES. CHIP (56.2 OHM 1%)	56.2 ohm 1/16W 1% 0603
R5062	CRJ10DJ473T	RES , CHIP	47K ohm 1/16W 5% 0603
R5063	CRJ10DJ473T	RES , CHIP	47K ohm 1/16W 5% 0603
R5064	CRJ10DJ473T	RES , CHIP	47K ohm 1/16W 5% 0603
R5065	CRJ10DJ103T	RES , CHIP	10K ohm 1/16W 5% 0603
R5066	CRJ10DJ473T	RES , CHIP	47K ohm 1/16W 5% 0603
R5067	CRJ10DJ0R0T	RES , CHIP	0 ohm 1/16W 0% 0603
R5068	CRJ10DJ101T	RES , CHIP	100 ohm 1/16W 5% 0603
R5069	CRJ10DJ0R0T	RES , CHIP	0 ohm 1/16W 0% 0603
R5070	CRJ10DJ0R0T	RES , CHIP	0 ohm 1/16W 0% 0603
R5071	CRJ10DF56R2T	RES. CHIP (56.2 OHM 1%)	56.2 ohm 1/16W 1% 0603
R5072	CRJ10DF56R2T	RES. CHIP (56.2 OHM 1%)	56.2 ohm 1/16W 1% 0603
R5073	CRJ10DF56R2T	RES. CHIP (56.2 OHM 1%)	56.2 ohm 1/16W 1% 0603
R5074	CRJ10DF56R2T	RES. CHIP (56.2 OHM 1%)	56.2 ohm 1/16W 1% 0603
R5075	CRJ10DJ0R0T	RES , CHIP	0 ohm 1/16W 0% 0603
R5149	CRJ10DJ330T	RES , CHIP	33 ohm 1/16W 5% 0603
R5150	CRJ10DJ0R0T	RES , CHIP	0 ohm 1/16W 0% 0603
R5151	CRJ10DJ0R0T	RES , CHIP	0 ohm 1/16W 0% 0603
T5000	CVIH1102NLT	I.C , MATCHING TRANS (10/100BASE-T,SING-PORT, SMD)	H1102NLT , PULSE
<i>Miscellaneous</i>			
HK5000	CMC1A337	BRACKET , GND SMALL AVR755	1
HK5001	CMC1A337	BRACKET , GND SMALL AVR755	1
JA5000	CJJ9L004Z	JACK , RJ-45	GDL1-8P8C 8T BK
N5001	CJP10GB116ZY	WAFER	GF120-10S-LS 1.25mm 10P
N5002	CJP10GB99ZY	WAFER	35237-1010 2.0mm 10P WHT
N5003	CJP11GB116ZY	WAFER	GF120-11S-LS 1.25mm 11P
N5004	CJP11GB116ZY	WAFER	GF120-11S-LS 1.25mm 11P
P5002	CJP05GB48ZW	WAFER	GIL-S-05P-S2L2-EF 5P
X5000	COX24576E180TF	CRYSTAL , 24.576MHz	CRYSTAL_HC-49/S_18PF
BD5008	CLZ9R010Z	BEAD , FERRITE (FCM2012KF-121T08 , 120 OHM)	
BD5009	CLZ9R010Z	BEAD , FERRITE (FCM2012KF-121T08 , 120 OHM)	
BD5010	CLZ9R010Z	BEAD , FERRITE (FCM2012KF-121T08 , 120 OHM)	
BD5011	CLZ9R010Z	BEAD , FERRITE (FCM2012KF-121T08 , 120 OHM)	
BD5012	CLZ9R010Z	BEAD , FERRITE (FCM2012KF-121T08 , 120 OHM)	
BD5013	CLZ9R010Z	BEAD , FERRITE (FCM2012KF-121T08 , 120 OHM)	
BD5000	CLZ9R010Z	BEAD , FERRITE (FCM2012KF-121T08 , 120 OHM)	FCM2012KF-121T08 120ohm 2012
BD5005	CLZ9R010Z	BEAD , FERRITE (FCM2012KF-121T08 , 120 OHM)	FCM2012KF-121T08 120ohm 2012
F5000	CRTMINISMDC200F	SW , POLY (RESETTABLE 2A 0.02 OHM 1W 4532)	MINISMDC200F-2
HDMI PCB ASS'Y		COP12041B	
<i>Capacitors</i>			
C2002	CCUS1H103KC	CAP , CHIP	0.01UF 50V K
C2003	CCUS1H104KC	CAP , CHIP	0.1UF 50V K
C2031	CCSJA1C100B	CAP , CHIP TANTAL(A TYPE, 10uF/16V, ELNA)	10uF 16V T491B106M016AS 3528
C2043	CCUS1H123KC	CAP , CHIP(1608, 50V/12NF)	1608, 50V/12NF
C2045	CCUS1H104KC	CAP , CHIP	0.1UF 50V K

Ref. Designator	Part Number	Description	Qty
HDMI PCB ASS'Y		COP12041B	
C2049	CCSJA1C100B	CAP , CHIP TANTAL(A TYPE, 10uF/16V, ELNA)	10uF 16V T491B106M016AS 3528
C2058	CCUS1H103KC	CAP , CHIP	0.01UF 50V K
C2059	CCUCOJ106KC	CAP , CHIP (10UF/6.3V K X5R 2012)	10uF 6.3V +-10% C2012JB0J106K
C2060	CCUS1H102KC	CAP , CHIP	1000PF 50V K
C2061	CCUS1H104KC	CAP , CHIP	0.1UF 50V K
C2062	CCUS1H104KC	CAP , CHIP	0.1UF 50V K
C2063	CCUCOJ106KC	CAP , CHIP (10UF/6.3V K X5R 2012)	10uF 6.3V +-10% C2012JB0J106K
C2066	CCUS1H122KC	CAP , CHIP	1200PF 50V K
C2067	CCUCOJ106KC	CAP , CHIP (10UF/6.3V K X5R 2012)	10uF 6.3V +-10% C2012JB0J106K
C2068	CCUS1H104KC	CAP , CHIP	0.1UF 50V K
C2069	CCUCOJ106KC	CAP , CHIP (10UF/6.3V K X5R 2012)	10uF 6.3V +-10% C2012JB0J106K
C2070	CCUCOJ106KC	CAP , CHIP (10UF/6.3V K X5R 2012)	10uF 6.3V +-10% C2012JB0J106K
C2071	CCUS1H104KC	CAP , CHIP	0.1UF 50V K
C2072	CCUS1H104KC	CAP , CHIP	0.1UF 50V K
C2073	CCUS1H104KC	CAP , CHIP	0.1UF 50V K
C2074	CCUS1H104KC	CAP , CHIP	0.1UF 50V K
C2075	CCUS1H104KC	CAP , CHIP	0.1UF 50V K
C2076	CCUS1H104KC	CAP , CHIP	0.1UF 50V K
C2077	CCUS1H104KC	CAP , CHIP	0.1UF 50V K
C2078	CCUCOJ106KC	CAP , CHIP (10UF/6.3V K X5R 2012)	10uF 6.3V +-10% C2012JB0J106K
C2079	CCUS1H104KC	CAP , CHIP	0.1UF 50V K
C2080	CCUS1H104KC	CAP , CHIP	0.1UF 50V K
C2081	CCUS1H104KC	CAP , CHIP	0.1UF 50V K
C2082	CCUS1H104KC	CAP , CHIP	0.1UF 50V K
C2083	CCUS1H104KC	CAP , CHIP	0.1UF 50V K
C2084	CCUS1H102KC	CAP , CHIP	1000PF 50V K
C2085	CCUS1H104KC	CAP , CHIP	0.1UF 50V K
C2086	CCUS1H104KC	CAP , CHIP	0.1UF 50V K
C2087	CCUS1H104KC	CAP , CHIP	0.1UF 50V K
C2088	CCUS1H104KC	CAP , CHIP	0.1UF 50V K
C2089	CCUS1H104KC	CAP , CHIP	0.1UF 50V K
C2090	CCUS1H104KC	CAP , CHIP	0.1UF 50V K
C2091	CCUS1H102KC	CAP , CHIP	1000PF 50V K
C2092	CCUS1H104KC	CAP , CHIP	0.1UF 50V K
C2093	CCUS1H102KC	CAP , CHIP	1000PF 50V K
C2094	CCSJA1C100B	CAP , CHIP TANTAL(A TYPE, 10uF/16V, ELNA)	10uF 16V T491B106M016AS 3528
C2095	CCUS1H104KC	CAP , CHIP	0.1UF 50V K
C2096	CCUS1H104KC	CAP , CHIP	0.1UF 50V K
C2097	CCUS1H104KC	CAP , CHIP	0.1UF 50V K
C2098	CCUS1H104KC	CAP , CHIP	0.1UF 50V K
C2099	CCUS1H102KC	CAP , CHIP	1000PF 50V K
C2100	CCUS1H104KC	CAP , CHIP	0.1UF 50V K
C2101	CCUCOJ106KC	CAP , CHIP (10UF/6.3V K X5R 2012)	10uF 6.3V +-10% C2012JB0J106K
C2102	CCUS1H104KC	CAP , CHIP	0.1UF 50V K
C2103	CCUS1H104KC	CAP , CHIP	0.1UF 50V K
C2104	CCUS1H102KC	CAP , CHIP	1000PF 50V K
C2105	CCUS1H104KC	CAP , CHIP	0.1UF 50V K
C2106	CCUCOJ106KC	CAP , CHIP (10UF/6.3V K X5R 2012)	10uF 6.3V +-10% C2012JB0J106K
C2107	CCUS1H102KC	CAP , CHIP	1000PF 50V K
C2108	CCUS1H180JA	CAP , CHIP(18PF/50V)	18PF 50V J
C2109	CCUS1H104KC	CAP , CHIP	0.1UF 50V K
C2110	CCUS1H104KC	CAP , CHIP	0.1UF 50V K
C2111	CCUS1H180JA	CAP , CHIP(18PF/50V)	18PF 50V J
C2112	CCUS1H104KC	CAP , CHIP	0.1UF 50V K
C2113	CCUCOJ106KC	CAP , CHIP (10UF/6.3V K X5R 2012)	10uF 6.3V +-10% C2012JB0J106K
C2114	CCUCOJ106KC	CAP , CHIP (10UF/6.3V K X5R 2012)	10uF 6.3V +-10% C2012JB0J106K
C2115	CCUS1H102KC	CAP , CHIP	1000PF 50V K
C2116	CCUS1H104KC	CAP , CHIP	0.1UF 50V K
C2117	CCUS1H104KC	CAP , CHIP	0.1UF 50V K
C2118	CCUS1H104KC	CAP , CHIP	0.1UF 50V K
C2119	CCSJA1C100B	CAP , CHIP TANTAL(A TYPE, 10uF/16V, ELNA)	10uF 16V T491B106M016AS 3528
C2120	CCUS1H104KC	CAP , CHIP	0.1UF 50V K
C2121	CCSJA0J220B	CAP , CHIP TANTAL(A TYPE, 22uF/6.3V, ELNA)	22uF 6V T491B226M006AS 3528
C2122	CCUS1H102KC	CAP , CHIP	1000PF 50V K
C2123	CCUS1H104KC	CAP , CHIP	0.1UF 50V K
C2124	CCUS1H104KC	CAP , CHIP	0.1UF 50V K
C2125	CCUS1H104KC	CAP , CHIP	0.1UF 50V K
C2126	CCUS1H104KC	CAP , CHIP	0.1UF 50V K
C2127	CCUS1H104KC	CAP , CHIP	0.1UF 50V K
C2128	CCUS1H104KC	CAP , CHIP	0.1UF 50V K
C2129	CCUCOJ106KC	CAP , CHIP (10UF/6.3V K X5R 2012)	10uF 6.3V +-10% C2012JB0J106K

Ref. Designator	Part Number	Description	Qty
HDMI PCB ASS'Y		COP12041B	
C2130	CCUC0J106KC	CAP , CHIP (10UF/6.3V K X5R 2012)	10uF 6.3V +-10% C2012JB0J106K
C2131	CCUC0J106KC	CAP , CHIP (10UF/6.3V K X5R 2012)	10uF 6.3V +-10% C2012JB0J106K
C2132	CCUS1H104KC	CAP , CHIP	0.1UF 50V K
C2133	CCUS1H102KC	CAP , CHIP	1000PF 50V K
C2134	CCUC0J106KC	CAP , CHIP (10UF/6.3V K X5R 2012)	10uF 6.3V +-10% C2012JB0J106K
C2135	CCUS1H104KC	CAP , CHIP	0.1UF 50V K
C2136	CCUC0J106KC	CAP , CHIP (10UF/6.3V K X5R 2012)	10uF 6.3V +-10% C2012JB0J106K
C2137	CCUS1H102KC	CAP , CHIP	1000PF 50V K
C2138	CCUS1H104KC	CAP , CHIP	0.1UF 50V K
C2139	CCUS1H104KC	CAP , CHIP	0.1UF 50V K
C2140	CCUS1H102KC	CAP , CHIP	1000PF 50V K
C2141	CCUS1H101JA	CAP , CHIP	100PF 50V J
C2142	CCUS1H101JA	CAP , CHIP	100PF 50V J
C2143	CCUS1H101JA	CAP , CHIP	100PF 50V J
C2144	CCUC0J106KC	CAP , CHIP (10UF/6.3V K X5R 2012)	10uF 6.3V +-10% C2012JB0J106K
C2145	CCUS1H104KC	CAP , CHIP	0.1UF 50V K
C2146	CCUS1H104KC	CAP , CHIP	0.1UF 50V K
C2147	CCUS1H102KC	CAP , CHIP	1000PF 50V K
C2148	CCUS1H102KC	CAP , CHIP	1000PF 50V K
C2149	CCUS1H104KC	CAP , CHIP	0.1UF 50V K
C2150	CCUS1H102KC	CAP , CHIP	1000PF 50V K
C2151	CCUS1H104KC	CAP , CHIP	0.1UF 50V K
C2152	CCUS1H104KC	CAP , CHIP	0.1UF 50V K
C2153	CCUS1H102KC	CAP , CHIP	1000PF 50V K
C2154	CCUS1H102KC	CAP , CHIP	1000PF 50V K
C2155	CCUC0J106KC	CAP , CHIP (10UF/6.3V K X5R 2012)	10uF 6.3V +-10% C2012JB0J106K
C2156	CCUS1H104KC	CAP , CHIP	0.1UF 50V K
C2157	CCUS1H104KC	CAP , CHIP	0.1UF 50V K
C2158	CCUS1H102KC	CAP , CHIP	1000PF 50V K
C2159	CCUS1H102KC	CAP , CHIP	1000PF 50V K
C2160	CCUS1H104KC	CAP , CHIP	0.1UF 50V K
C2161	CCUS1H102KC	CAP , CHIP	1000PF 50V K
C2162	CCSJA0J220B	CAP , CHIP TANTAL(A TYPE, 22uF/6.3V, ELNA)	22uF 6V T491B226M006AS 3528
C2163	CCUC0J106KC	CAP , CHIP (10UF/6.3V K X5R 2012)	10uF 6.3V +-10% C2012JB0J106K
C2164	CCUC0J106KC	CAP , CHIP (10UF/6.3V K X5R 2012)	10uF 6.3V +-10% C2012JB0J106K
C2165	CCSJA0J220B	CAP , CHIP TANTAL(A TYPE, 22uF/6.3V, ELNA)	22uF 6V T491B226M006AS 3528
C2166	CCUS1H102KC	CAP , CHIP	1000PF 50V K
C2167	CCUS1H104KC	CAP , CHIP	0.1UF 50V K
C2168	CCUS1H102KC	CAP , CHIP	1000PF 50V K
C2169	CCUS1H104KC	CAP , CHIP	0.1UF 50V K
C2170	CCUS1H101JA	CAP , CHIP	100PF 50V J
C2171	CCUS1H104KC	CAP , CHIP	0.1UF 50V K
C2172	CCUS1H104KC	CAP , CHIP	0.1UF 50V K
C2173	CCSJA0J220B	CAP , CHIP TANTAL(A TYPE, 22uF/6.3V, ELNA)	22uF 6V T491B226M006AS 3528
C2174	CCUC0J106KC	CAP , CHIP (10UF/6.3V K X5R 2012)	10uF 6.3V +-10% C2012JB0J106K
C2175	CCSJA0J220B	CAP , CHIP TANTAL(A TYPE, 22uF/6.3V, ELNA)	22uF 6V T491B226M006AS 3528
C2176	CCUS1H104KC	CAP , CHIP	0.1UF 50V K
C2177	CCUC0J106KC	CAP , CHIP (10UF/6.3V K X5R 2012)	10uF 6.3V +-10% C2012JB0J106K
C2178	CCUS1H104KC	CAP , CHIP	0.1UF 50V K
C2179	CCUS1H103KC	CAP , CHIP	0.01UF 50V K
C2180	CCUS1H104KC	CAP , CHIP	0.1UF 50V K
C2181	CCUS1H103KC	CAP , CHIP	0.01UF 50V K
C2182	CCUC0J106KC	CAP , CHIP (10UF/6.3V K X5R 2012)	10uF 6.3V +-10% C2012JB0J106K
C2183	CCUS1H103KC	CAP , CHIP	0.01UF 50V K
C2184	CCUS1H103KC	CAP , CHIP	0.01UF 50V K
C2185	CCUC0J106KC	CAP , CHIP (10UF/6.3V K X5R 2012)	10uF 6.3V +-10% C2012JB0J106K
C2186	CCUS1H103KC	CAP , CHIP	0.01UF 50V K
C2187	CCUS1H104KC	CAP , CHIP	0.1UF 50V K
C2188	CCUS1H103KC	CAP , CHIP	0.01UF 50V K
C2189	CCUS1H103KC	CAP , CHIP	0.01UF 50V K
C2190	CCUS1H103KC	CAP , CHIP	0.01UF 50V K
C2191	CCUS1H103KC	CAP , CHIP	0.01UF 50V K
C2192	CCUS1H104KC	CAP , CHIP	0.1UF 50V K
C2193	CCUS1H104KC	CAP , CHIP	0.1UF 50V K
C2194	CCUC0J106KC	CAP , CHIP (10UF/6.3V K X5R 2012)	10uF 6.3V +-10% C2012JB0J106K
C2195	CCUS1H103KC	CAP , CHIP	0.01UF 50V K
C2196	CCUS1H104KC	CAP , CHIP	0.1UF 50V K
C2197	CCUS1H104KC	CAP , CHIP	0.1UF 50V K
C2198	CCUS1H104KC	CAP , CHIP	0.1UF 50V K
C2199	CCUS1H104KC	CAP , CHIP	0.1UF 50V K
C2200	CCUS1H104KC	CAP , CHIP	0.1UF 50V K

Ref. Designator	Part Number	Description	Qty
HDMI PCB ASS'Y		COP12041B	
C2201	CCUS1H104KC	CAP , CHIP	0.1UF 50V K
C2202	CCUS1H103KC	CAP , CHIP	0.01UF 50V K
C2203	CCUS1H104KC	CAP , CHIP	0.1UF 50V K
C2204	CCUS1H104KC	CAP , CHIP	0.1UF 50V K
C2205	CCUS1H103KC	CAP , CHIP	0.01UF 50V K
C2206	CCUS1H104KC	CAP , CHIP	0.1UF 50V K
C2207	CCUS1H104KC	CAP , CHIP	0.1UF 50V K
C2208	CCUS1H104KC	CAP , CHIP	0.1UF 50V K
C2209	CCUS1H104KC	CAP , CHIP	0.1UF 50V K
C2210	CCUS1H104KC	CAP , CHIP	0.1UF 50V K
C2211	CCUS1H104KC	CAP , CHIP	0.1UF 50V K
C2212	CCUS1H104KC	CAP , CHIP	0.1UF 50V K
C2213	CCUS1H104KC	CAP , CHIP	0.1UF 50V K
C2214	CCUS1H103KC	CAP , CHIP	0.01UF 50V K
C2215	CCUS1H104KC	CAP , CHIP	0.1UF 50V K
C2216	CCUS1H104KC	CAP , CHIP	0.1UF 50V K
C2217	CCUS1H104KC	CAP , CHIP	0.1UF 50V K
C2218	CCUS1H104KC	CAP , CHIP	0.1UF 50V K
C2219	CCUS1H104KC	CAP , CHIP	0.1UF 50V K
C2220	CCUS1H104KC	CAP , CHIP	0.1UF 50V K
C2221	CCUS1H104KC	CAP , CHIP	0.1UF 50V K
C2222	CCUS1H103KC	CAP , CHIP	0.01UF 50V K
C2223	CCUS1H104KC	CAP , CHIP	0.1UF 50V K
C2224	CCSJA0J220B	CAP , CHIP TANTAL(A TYPE, 22uF/6.3V, ELNA)	22uF 6V T491B226M006AS 3528
C2225	CCSJA0J220B	CAP , CHIP TANTAL(A TYPE, 22uF/6.3V, ELNA)	22uF 6V T491B226M006AS 3528
C2226	CCUS1H103KC	CAP , CHIP	0.01UF 50V K
C2227	CCSJA0J220B	CAP , CHIP TANTAL(A TYPE, 22uF/6.3V, ELNA)	22uF 6V T491B226M006AS 3528
C2228	CCUS1H104KC	CAP , CHIP	0.1UF 50V K
C2229	CCUS1H104KC	CAP , CHIP	0.1UF 50V K
C2230	CCSJA0J220B	CAP , CHIP TANTAL(A TYPE, 22uF/6.3V, ELNA)	22uF 6V T491B226M006AS 3528
C2231	CCUS1H103KC	CAP , CHIP	0.01UF 50V K
C2232	CCUS1H104KC	CAP , CHIP	0.1UF 50V K
C2233	CCUS1H104KC	CAP , CHIP	0.1UF 50V K
C2234	CCUS1H104KC	CAP , CHIP	0.1UF 50V K
C2235	CCUS1H104KC	CAP , CHIP	0.1UF 50V K
C2236	CCUS1H104KC	CAP , CHIP	0.1UF 50V K
C2237	CCUS1H103KC	CAP , CHIP	0.01UF 50V K
C2238	CCUS1H103KC	CAP , CHIP	0.01UF 50V K
C2239	CCUS1H104KC	CAP , CHIP	0.1UF 50V K
C2240	CCUS1H104KC	CAP , CHIP	0.1UF 50V K
C2241	CCUS1H104KC	CAP , CHIP	0.1UF 50V K
C2242	CCUS1H104KC	CAP , CHIP	0.1UF 50V K
C2243	CCUS1H103KC	CAP , CHIP	0.01UF 50V K
C2244	CCUS1H104KC	CAP , CHIP	0.1UF 50V K
C2245	CCUS1H104KC	CAP , CHIP	0.1UF 50V K
C2246	CCUS1H104KC	CAP , CHIP	0.1UF 50V K
C2247	CCSJA0J220B	CAP , CHIP TANTAL(A TYPE, 22uF/6.3V, ELNA)	22uF 6V T491B226M006AS 3528
C2248	CCUS1H104KC	CAP , CHIP	0.1UF 50V K
C2249	CCUS1H104KC	CAP , CHIP	0.1UF 50V K
C2250	CCUS1H103KC	CAP , CHIP	0.01UF 50V K
C2251	CCUS1H104KC	CAP , CHIP	0.1UF 50V K
C2252	CCUS1H104KC	CAP , CHIP	0.1UF 50V K
C2253	CCUS1H103KC	CAP , CHIP	0.01UF 50V K
C2254	CCSJA0J220B	CAP , CHIP TANTAL(A TYPE, 22uF/6.3V, ELNA)	22uF 6V T491B226M006AS 3528
C2255	CCUS1H104KC	CAP , CHIP	0.1UF 50V K
C2256	CCUS1H104KC	CAP , CHIP	0.1UF 50V K
C2257	CCUS1H104KC	CAP , CHIP	0.1UF 50V K
C2258	CCUS1H104KC	CAP , CHIP	0.1UF 50V K
C2259	CCUS1H104KC	CAP , CHIP	0.1UF 50V K
C2260	CCUS1H104KC	CAP , CHIP	0.1UF 50V K
C2261	CCUS1H104KC	CAP , CHIP	0.1UF 50V K
C2262	CCUS1H104KC	CAP , CHIP	0.1UF 50V K
C2263	CCUS1H104KC	CAP , CHIP	0.1UF 50V K
C2264	CCUS1H104KC	CAP , CHIP	0.1UF 50V K
C2265	CCUS1H104KC	CAP , CHIP	0.1UF 50V K
C2266	CCUS1H104KC	CAP , CHIP	0.1UF 50V K
C2267	CCUS1H103KC	CAP , CHIP	0.01UF 50V K
C2268	CCUS1H104KC	CAP , CHIP	0.1UF 50V K
C2269	CCUS1H103KC	CAP , CHIP	0.01UF 50V K
C2270	CCUS1H104KC	CAP , CHIP	0.1UF 50V K
C2271	CCSJA0J220B	CAP , CHIP TANTAL(A TYPE, 22uF/6.3V, ELNA)	22uF 6V T491B226M006AS 3528

Ref. Designator	Part Number	Description	Qty
HDMI PCB ASS'Y		COP12041B	
C2272	CCUS1H104KC	CAP , CHIP	0.1UF 50V K
C2273	CCUS1H104KC	CAP , CHIP	0.1UF 50V K
C2274	CCUS1H104KC	CAP , CHIP	0.1UF 50V K
C2275	CCUS1H104KC	CAP , CHIP	0.1UF 50V K
C2276	CCUS1H470JA	CAP , CHIP	47PF 50V J
C2277	CCUS1H470JA	CAP , CHIP	47PF 50V J
C2278	CCUS1H103KC	CAP , CHIP	0.01UF 50V K
C2279	CCUC0J106KC	CAP , CHIP (10UF/6.3V K X5R 2012)	10uF 6.3V +-10% C2012JB0J106K
C2280	CCUS1H103KC	CAP , CHIP	0.01UF 50V K
C2281	CCUS1H103KC	CAP , CHIP	0.01UF 50V K
C2282	CCUC0J106KC	CAP , CHIP (10UF/6.3V K X5R 2012)	10uF 6.3V +-10% C2012JB0J106K
C2283	CCUS1H103KC	CAP , CHIP	0.01UF 50V K
C2284	CCUS1H101JA	CAP , CHIP	100PF 50V J
C2285	CCUS1H104KC	CAP , CHIP	0.1UF 50V K
C2286	CCSJA0J220B	CAP , CHIP TANTAL(A TYPE, 22uF/6.3V, ELNA)	22uF 6V T491B226M006AS 3528
C2287	CCUC0J106KC	CAP , CHIP (10UF/6.3V K X5R 2012)	10uF 6.3V +-10% C2012JB0J106K
C2289	CCUS1H103KC	CAP , CHIP	0.01UF 50V K
C2290	CCUS1H103KC	CAP , CHIP	0.01UF 50V K
C2291	CCUS1H103KC	CAP , CHIP	0.01UF 50V K
C2292	CCUS1H103KC	CAP , CHIP	0.01UF 50V K
C2294	CCUS1H103KC	CAP , CHIP	0.01UF 50V K
C2295	CCSJA0J220B	CAP , CHIP TANTAL(A TYPE, 22uF/6.3V, ELNA)	22uF 6V T491B226M006AS 3528
C2296	CCUS1H103KC	CAP , CHIP	0.01UF 50V K
C2297	CCUS1H104KC	CAP , CHIP	0.1UF 50V K
C2298	CCUS1H103KC	CAP , CHIP	0.01UF 50V K
C2299	CCUS1H103KC	CAP , CHIP	0.01UF 50V K
C2300	CCUS1H104KC	CAP , CHIP	0.1UF 50V K
C2302	CCSJA0J220B	CAP , CHIP TANTAL(A TYPE, 22uF/6.3V, ELNA)	22uF 6V T491B226M006AS 3528
C2303	CCSJA0J220B	CAP , CHIP TANTAL(A TYPE, 22uF/6.3V, ELNA)	22uF 6V T491B226M006AS 3528
C2304	CCUS1H104KC	CAP , CHIP	0.1UF 50V K
C2305	CCUS1H103KC	CAP , CHIP	0.01UF 50V K
C2306	CCSJA0J220B	CAP , CHIP TANTAL(A TYPE, 22uF/6.3V, ELNA)	22uF 6V T491B226M006AS 3528
C2307	CCUS1H103KC	CAP , CHIP	0.01UF 50V K
C2308	CCUC0J106KC	CAP , CHIP (10UF/6.3V K X5R 2012)	10uF 6.3V +-10% C2012JB0J106K
C2309	CCSJA0J220B	CAP , CHIP TANTAL(A TYPE, 22uF/6.3V, ELNA)	22uF 6V T491B226M006AS 3528
C2310	CCUS1H123KC	CAP , CHIP(1608, 50V/12NF)	1608, 50V/12NF
C2311	CCUS1H222KC	CAP , CHIP	2200PF 50V K
C2312	CCUS1H104KC	CAP , CHIP	0.1UF 50V K
C2313	CCUS1H104KC	CAP , CHIP	0.1UF 50V K
C2314	CCUS1H104KC	CAP , CHIP	0.1UF 50V K
C2315	CCUS1H104KC	CAP , CHIP	0.1UF 50V K
C2316	CCUS1H104KC	CAP , CHIP	0.1UF 50V K
C2317	CCUS1H104KC	CAP , CHIP	0.1UF 50V K
C2319	CCUS1H104KC	CAP , CHIP	0.1UF 50V K
C2320	CCUS1H104KC	CAP , CHIP	0.1UF 50V K
C2007	CCUS1H104KC	CAP , CHIP	0.1UF 50V K
C2008	CCUS1H104KC	CAP , CHIP	0.1UF 50V K
C2009	CCUS1H220JA	CAP , CHIP	22PF 50V J
C2010	CCSJA0J220B	CAP , CHIP TANTAL(A TYPE, 22uF/6.3V, ELNA)	22uF 6V T491B226M006AS 3528
C2011	CCUS1H330JA	CAP , CHIP	33PF 50V J
C2012	CCUS1H104KC	CAP , CHIP	0.1UF 50V K
C2013	CCUS1H104KC	CAP , CHIP	0.1UF 50V K
C2014	CCUS1H103KC	CAP , CHIP	0.01UF 50V K
C2015	CCUS1H104KC	CAP , CHIP	0.1UF 50V K
C2016	CCUS1H104KC	CAP , CHIP	0.1UF 50V K
C2017	CCUS1H103KC	CAP , CHIP	0.01UF 50V K
C2018	CCUS1H103KC	CAP , CHIP	0.01UF 50V K
C2019	CCUC0J106KC	CAP , CHIP (10UF/6.3V K X5R 2012)	10uF 6.3V +-10% C2012JB0J106K
C2020	CCUS1H104KC	CAP , CHIP	0.1UF 50V K
C2021	CCUS1H101JA	CAP , CHIP	100PF 50V J
C2022	CCUS1H101JA	CAP , CHIP	100PF 50V J
C2023	CCUS1H104KC	CAP , CHIP	0.1UF 50V K
C2024	CCUS1H104KC	CAP , CHIP	0.1UF 50V K
C2025	CCUS1H104KC	CAP , CHIP	0.1UF 50V K
C2026	CCUS1H104KC	CAP , CHIP	0.1UF 50V K
C2027	CCSJA0J220B	CAP , CHIP TANTAL(A TYPE, 22uF/6.3V, ELNA)	22uF 6V T491B226M006AS 3528
C2028	CCUS1H104KC	CAP , CHIP	0.1UF 50V K
C2029	CCUS1H104KC	CAP , CHIP	0.1UF 50V K
C2030	CCUS1H104KC	CAP , CHIP	0.1UF 50V K
C2032	CCUS1H104KC	CAP , CHIP	0.1UF 50V K
C2033	CCUS1H104KC	CAP , CHIP	0.1UF 50V K

Ref. Designator	Part Number	Description		Qty
HDMI PCB ASS'Y		COP12041B		
C2034	CCUS1H104KC	CAP , CHIP	0.1UF 50V K	1
C2035	CCUS1H104KC	CAP , CHIP	0.1UF 50V K	1
C2036	CCUS1H104KC	CAP , CHIP	0.1UF 50V K	1
C2037	CCUS1H104KC	CAP , CHIP	0.1UF 50V K	1
C2038	CCUS1H104KC	CAP , CHIP	0.1UF 50V K	1
C2039	CCUS1H103KC	CAP , CHIP	0.01UF 50V K	1
C2041	CCSJA0J220B	CAP , CHIP TANTAL(A TYPE, 22uF/6.3V, ELNA)	22uF 6V T491B226M006AS 3528	1
C2042	CCUS1H101JA	CAP , CHIP	100PF 50V J	1
C2044	CCUS1H101JA	CAP , CHIP	100PF 50V J	1
C2046	CCUS1H222KC	CAP , CHIP	2200PF 50V K	1
C2047	CCUS1H104KC	CAP , CHIP	0.1UF 50V K	1
C2048	CCUS1H330JA	CAP , CHIP	33PF 50V J	1
C2288	CCSJA1C100B	CAP , CHIP TANTAL(A TYPE, 10uF/16V, ELNA)	10uF 16V T491B106M016AS 3528	1
C2327	CCUS1H122KC	CAP , CHIP	1200PF 50V K	1
C2040	CCEA1AH101T	CAP , ELECT	100UF 10V	1
C2050	CCEA1AH221T	CAP , ELECT	220UF 10V	1
C2051	CCEA0JH102T	CAP , ELECT	1000UF 6.3V	1
C2052	CCEA1CH470T	CAP , ELECT	47UF 16V	1
C2053	CCEA1AH221T	CAP , ELECT	220UF 10V	1
C2054	CCEA1HH100T	CAP , ELECT	10UF 50V	1
C2301	CCEA1AH101T	CAP , ELECT	100UF 10V	1
C2318	CCEA1CH470T	CAP , ELECT	47UF 16V	1
<i>Semiconductors</i>				
D2014	CVDBAV99LT1G	DIODE , SWITCHING SOT-23	BAV99LT1G SOT-23	1
D2015	CVDBAV99LT1G	DIODE , SWITCHING SOT-23	BAV99LT1G SOT-23	1
D2016	HVD1SS355T	DIODE , CHIP	1SS355TE-17	1
D2017	HVD1SS355T	DIODE , CHIP	1SS355TE-17	1
D2019	HVD1SS355T	DIODE , CHIP	1SS355TE-17	1
IC2010	CVI74FCT38072DCGI	I.C , CLOCK DRIVER	IDT74FCT38072DCGI , IDT	1
IC2015	HVILM1117S-1V8	I.C , REGULATOR (1.8V)	LM1117-1V8	1
IC2017	HVILM1117S-1V8	I.C , REGULATOR (1.8V)	LM1117-1V8	1
IC2023	HVILM1117S-3V3	I.C , REGULATOR (3.3V)	1117S-3.3V	1
IC2028	HVILM1117S-2V5	I.C , REGULATOR (2.5V)	1117S-2.5	1
IC2033	HVILM1117S-1V8	I.C , REGULATOR (1.8V)	LM1117-1V8	1
IC2036	CVICD74HC4053M96	IC, MULTIPLEXERS, CD74HC4053M96, TI	CD74HC4053M96	1
IC2037	CVISN74LVC1G04DCKR	I.C , SINGLE INVERTER GATE SC-70	SN74LVC1G04DCKR , TI(AVNET)	1
IC2039	CVDAD1580BRT	I.C, 1.2V MCRPWR,PREC SHUNT VOLTAGE REF.	AD1580BRTZ-REEL	1
IC2040	CVISN74LVC1G125DBV	I.C , SINGLE BUS BUFFER GATE SOT(SOT-23)DBV	SN74LVC1G125DBV	1
Q2004	HVTKTA1504SYRTK	TRANSISTOR , CHIP PNP	KTA1504S Y RTK	1
Q2005	HVTKTA1504SYRTK	TRANSISTOR , CHIP PNP	KTA1504S Y RTK	1
Q2006	CVT2N7002K	F.E.T(SOP-23)	2N7002K	1
Q2007	CVT2N7002K	F.E.T(SOP-23)	2N7002K	1
Q2008	HVTKRC107S	TRANSISTOR , CHIP NPN	KRC107S SOT-23	1
Q2009	HVTKRC107S	TRANSISTOR , CHIP NPN	KRC107S SOT-23	1
Q2010	HVTKRC107S	TRANSISTOR , CHIP NPN	KRC107S SOT-23	1
Q2011	HVTKRC107S	TRANSISTOR , CHIP NPN	KRC107S SOT-23	1
D2002	CVDBAV99LT1G	DIODE , SWITCHING SOT-23	BAV99LT1G SOT-23	1
D2003	CVDBAV99LT1G	DIODE , SWITCHING SOT-23	BAV99LT1G SOT-23	1
D2004	CVDBAV99LT1G	DIODE , SWITCHING SOT-23	BAV99LT1G SOT-23	1
D2006	HVD1SS355T	DIODE , CHIP	1SS355TE-17	1
D2007	HVD1SS355T	DIODE , CHIP	1SS355TE-17	1
D2008	HVD1SS355T	DIODE , CHIP	1SS355TE-17	1
D2009	HVD1SS355T	DIODE , CHIP	1SS355TE-17	1
D2010	HVD1SS355T	DIODE , CHIP	1SS355TE-17	1
D2011	HVD1SS355T	DIODE , CHIP	1SS355TE-17	1
D2020	HVD1SS355T	DIODE , CHIP	1SS355TE-17	1
IC2000	CVIPC17K1CTN	I.C , PHOTO COUPLER CHIP , PC17K1CTN	PC17K1CTN , KODENSHI	1
IC2001	CVIPC17K1CTN	I.C , PHOTO COUPLER CHIP , PC17K1CTN	PC17K1CTN , KODENSHI	1
IC2002	CVIBU4052BCF	I.C , ANALOG 4CHX2,MPX/DEMPX SOP-16	BU4052BCF SOP16	1
IC2004	CVISII9185ACTU	I.C , HDMI RX SW(80PIN TQFP)	SI9185ACTU	1
IC2005	CVTUPA672T	F.E.T	UPA672T-T1-A SMD	1
IC2006	CVTUPA672T	F.E.T	UPA672T-T1-A SMD	1
IC2007	CVISC16IS740IPW	I.C , Single UART with I2C-bus/SPI interface	SC16IS740IPW TSSOP16	1
IC2008	CVISN74LVC257AD	I.C , Data Selector/Multiplexer With 3-State Outputs	SN74LVC257AD SOIC-16	1
IC2009	CVISII9135CTU	IC , HDMI RX(144PIN, TQFP)	144PIN, TQFP	1
IC2011	CVIM24C08WMN6TP	I.C , EEPROM (8KBits, 400MHz, 2.5-5.5V, SOP-8)	M24C08-WMN6TP, ST	1
IC2012	CVIBU4094BCF	I.C , 8-bit compatible shift / store register	BU4094BCF SOP16	1
IC2013	CVIBU4094BCF	I.C , 8-bit compatible shift / store register	BU4094BCF SOP16	1
IC2014	CVISN74LVC827APWR	I.C,0-BIT BUFFER/DRIVER TSSOP24 TEXAS INSTRUMENTS	SN74LVC827APWT TSSOP24	1

Ref. Designator	Part Number	Description		Qty
HDMI PCB ASS'Y		COP12041B		
IC2016	CVISII9134CTU	IC , HDMI TX(100PIN, TQFP)	SI9134CTU TQFP100	1
IC2018	CVISN74LVC257AD	I.C , SN74LVC257AD SOIC-16	SN74LVC257AD SOIC-16	1
IC2019	CVIFLI30336AC	I.C , VIDEO PROCESSOR	FLI30336-LF-AC	1
IC2020	CVISN74LVC1G125DBVR	I.C , SINGLE BUS BUFFER GATE SOT(SOT-23)DBV	SN74LVC1G125DBVR SOT23	1
IC2021	CVISN74ALVCH16827DGG	I.C , BUFFER/DRIVER	SN74ALVCH16827DGGR , TI	1
IC2022	CVISN74ALVCH16827DGG	I.C , BUFFER/DRIVER	SN74ALVCH16827DGGR , TI	1
IC2024	CVIA3S56D40ETPG5	I.C, 256MB DDR SDRAM	A3S56D40ETP-G5	1
IC2025	CVIMK2302S01T	I.C , BUFFER	MK2302S-01T	1
IC2026	CVIF49L320UA70TG	I.C , 32M FLASH(48PIN TSOPI)	F49L320UA70TG	1
IC2027	CVIA3S56D40ETPG5	I.C, 256MB DDR SDRAM	A3S56D40ETP-G5	1
IC2030	CVISN74ALVCH16827DGG	I.C , BUFFER/DRIVER	SN74ALVCH16827DGGR , TI	1
IC2031	CVISN74ALVCH16827DGG	I.C , BUFFER/DRIVER	SN74ALVCH16827DGGR , TI	1
IC2032	CVIADV7340BSTZ	I.C , VIDEO ENCODER	ADV7340	1
IC2034	CVIADA4410-6ACPZ	I.C , VIDEO FILTER W/SEL- CUTOFF FREQ.32P	ADA4410-6ACPZ VQ_LFCSP-32PIN	1
Q2000	HVTKRA107MT	TRANSISTOR PNP	KRA107M	1
Q2001	HVTKRA107MT	TRANSISTOR PNP	KRA107M	1
	HVIA278R33PI	REGULATOR(3.3V OUTPUT LOWDROP)	KIA278R33PI	1
	CVIFAN1084T	I.C , REGULATOR 4.5A LDO T0-220	FAN1084T	1
IC2029	CVIFAN1084TZA	I.C , HEAT SINK ASS'Y(FAN1084T + CMY2A223)	FAN1084+CMY2A223, FAIRCHILD	1
IC2035	CVIKIA278R33PIVA	I.C , HEAT SINK ASS'Y (KIA278R33PI + CMY2A223)	KIA278R33PI+CMY2A223, KEC	1
Q2002	CVTKRC402ERTKP	TRANSISTOR , NPN	KRC402E-RTK/P , KEC	1
Q2012	HVTKTA1504SYRTK	TRANSISTOR , CHIP PNP	KTA1504S Y RTK	1
Q2013	HVTKTA1504SYRTK	TRANSISTOR , CHIP PNP	KTA1504S Y RTK	1
<i>Resistors</i>				
R2208	CRJ10DF75R0T	RES , CHIP 1% 75 OHM	75 ohm 1/16W 1% 0603	1
R2242	CRJ10DJ0R0T	RES , CHIP	0 ohm 1/16W 0% 0603	1
R2243	CRJ10DJ330T	RES , CHIP	33 ohm 1/16W 5% 0603	1
R2246	CRJ10DF1690T	RES , CHIP(1/10W, 169OHM, 1%)	169 ohm 1/16W 1% 0603	1
R2267	CRJ10DJ102T	RES , CHIP	1K ohm 1/16W 5% 0603	1
R2268	CRJ10DJ471T	RES , CHIP	470 ohm 1/16W 5% 0603	1
R2269	CRJ10DJ271T	RES , CHIP	270 ohm 1/16W 5% 0603	1
R2270	CRJ10DJ103T	RES , CHIP	10K ohm 1/16W 5% 0603	1
R2271	CRJ10DJ101T	RES , CHIP	100 ohm 1/16W 5% 0603	1
R2275	CRJ10DJ104T	RES , CHIP	100K ohm 1/16W 5% 0603	1
R2276	CRJ10DJ223T	RES , CHIP	22K ohm 1/16W 5% 0603	1
R2277	CRJ10DJ392T	RES , CHIP	3K9 ohm 1/16W 5% 0603	1
R2278	CRJ10DJ103T	RES , CHIP	10K ohm 1/16W 5% 0603	1
R2279	CRJ10DJ104T	RES , CHIP	100K ohm 1/16W 5% 0603	1
R2280	CRJ10DJ104T	RES , CHIP	100K ohm 1/16W 5% 0603	1
R2281	CRJ10DJ103T	RES , CHIP	10K ohm 1/16W 5% 0603	1
R2282	CRJ10DJ473T	RES , CHIP	47K ohm 1/16W 5% 0603	1
R2284	CRJ10DJ472T	RES , CHIP	4K7ohm 1/16W 5% 0603	1
R2285	CRJ10DJ621T	RES , CHIP	620 ohm 1/16W 5% 0603	1
R2286	CRJ10DJ330T	RES , CHIP	33 ohm 1/16W 5% 0603	1
R2287	CRJ10DJ103T	RES , CHIP	10K ohm 1/16W 5% 0603	1
R2288	CRJ10DJ105T	RES , CHIP	1M ohm 1/16W 5% 0603	1
R2289	CRJ10DJ472T	RES , CHIP	4K7ohm 1/16W 5% 0603	1
R2290	CRJ10DJ101T	RES , CHIP	100 ohm 1/16W 5% 0603	1
R2291	CRJ10DJ101T	RES , CHIP	100 ohm 1/16W 5% 0603	1
R2293	CRJ10DJ0R0T	RES , CHIP	0 ohm 1/16W 0% 0603	1
R2294	CRJ10DJ0R0T	RES , CHIP	0 ohm 1/16W 0% 0603	1
R2295	CRJ10DJ470T	RES , CHIP	47 ohm 1/16W 5% 0603	1
R2298	CRJ10DJ102T	RES , CHIP	1K ohm 1/16W 5% 0603	1
R2299	CRJ10DJ472T	RES , CHIP	4K7ohm 1/16W 5% 0603	1
R2300	CRJ10DJ472T	RES , CHIP	4K7ohm 1/16W 5% 0603	1
R2301	CRJ10DJ220T	RES , CHIP	22 ohm 1/16W 5% 0603	1
R2302	CRJ10DJ0R0T	RES , CHIP	0 ohm 1/16W 0% 0603	1
R2303	CRJ10DJ220T	RES , CHIP	22 ohm 1/16W 5% 0603	1
R2304	CRJ10DJ220T	RES , CHIP	22 ohm 1/16W 5% 0603	1
R2305	CRJ10DJ220T	RES , CHIP	22 ohm 1/16W 5% 0603	1
R2306	CRJ10DJ220T	RES , CHIP	22 ohm 1/16W 5% 0603	1
R2307	CRJ10DJ0R0T	RES , CHIP	0 ohm 1/16W 0% 0603	1
R2308	CRJ10DJ0R0T	RES , CHIP	0 ohm 1/16W 0% 0603	1
R2309	CRJ10DJ0R0T	RES , CHIP	0 ohm 1/16W 0% 0603	1
R2310	CRJ10DJ0R0T	RES , CHIP	0 ohm 1/16W 0% 0603	1
R2311	CRJ10DJ0R0T	RES , CHIP	0 ohm 1/16W 0% 0603	1
R2312	CRJ10DJ0R0T	RES , CHIP	0 ohm 1/16W 0% 0603	1
R2313	CRJ10DJ0R0T	RES , CHIP	0 ohm 1/16W 0% 0603	1
R2314	CRJ10DJ0R0T	RES , CHIP	0 ohm 1/16W 0% 0603	1

Ref. Designator	Part Number	Description	Qty
HDMI PCB ASS'Y		COP12041B	
R2315	CRJ10DJ220T	RES , CHIP	22 ohm 1/16W 5% 0603
R2316	CRJ10DJ750T	RES , CHIP	75 ohm 1/16W 5% 0603
R2317	CRJ10DJ220T	RES , CHIP	22 ohm 1/16W 5% 0603
R2318	CRJ10DJ0R0T	RES , CHIP	0 ohm 1/16W 0% 0603
R2319	CRJ10DJ220T	RES , CHIP	22 ohm 1/16W 5% 0603
R2320	CRJ10DJ0R0T	RES , CHIP	0 ohm 1/16W 0% 0603
R2321	CRJ10DJ0R0T	RES , CHIP	0 ohm 1/16W 0% 0603
R2322	CRJ10DJ0R0T	RES , CHIP	0 ohm 1/16W 0% 0603
R2323	CRJ10DJ0R0T	RES , CHIP	0 ohm 1/16W 0% 0603
R2324	CRJ10DJ0R0T	RES , CHIP	0 ohm 1/16W 0% 0603
R2325	CRJ10DJ0R0T	RES , CHIP	0 ohm 1/16W 0% 0603
R2326	CRJ10DJ0R0T	RES , CHIP	0 ohm 1/16W 0% 0603
R2328	CRJ10DJ220T	RES , CHIP	22 ohm 1/16W 5% 0603
R2329	CRJ10DJ0R0T	RES , CHIP	0 ohm 1/16W 0% 0603
R2330	CRJ10DJ0R0T	RES , CHIP	0 ohm 1/16W 0% 0603
R2331	CRJ10DJ0R0T	RES , CHIP	0 ohm 1/16W 0% 0603
R2332	CRJ10DJ0R0T	RES , CHIP	0 ohm 1/16W 0% 0603
R2333	CRJ10DJ0R0T	RES , CHIP	0 ohm 1/16W 0% 0603
R2334	CRJ10DF2800T	RES , CHIP(1/10W, 280ohm, 1608, 1%)	1/10W, 280OHM, 1608, 1%
R2335	CRJ10DJ0R0T	RES , CHIP	0 ohm 1/16W 0% 0603
R2336	CRJ10DJ272T	RES , CHIP	2K7 ohm 1/16W 5% 0603
R2337	CRJ104DJ330T	RES , 4ARRAY (1608*4)	33ohm 1/16W 5% CN34JT330
R2338	CRJ10DJ103T	RES , CHIP	10K ohm 1/16W 5% 0603
R2339	CRJ104DJ330T	RES , 4ARRAY (1608*4)	33ohm 1/16W 5% CN34JT330
R2340	CRJ104DJ330T	RES , 4ARRAY (1608*4)	33ohm 1/16W 5% CN34JT330
R2341	CRJ10DF2800T	RES , CHIP(1/10W, 280ohm, 1608, 1%)	1/10W, 280OHM, 1608, 1%
R2342	CRJ104DJ330T	RES , 4ARRAY (1608*4)	33ohm 1/16W 5% CN34JT330
R2343	CRJ104DJ330T	RES , 4ARRAY (1608*4)	33ohm 1/16W 5% CN34JT330
R2344	CRJ10DJ330T	RES , CHIP	33 ohm 1/16W 5% 0603
R2345	CRJ10DJ103T	RES , CHIP	10K ohm 1/16W 5% 0603
R2347	CRJ10DJ103T	RES , CHIP	10K ohm 1/16W 5% 0603
R2349	CRJ10DJ0R0T	RES , CHIP	0 ohm 1/16W 0% 0603
R2350	CRJ10DJ0R0T	RES , CHIP	0 ohm 1/16W 0% 0603
R2351	CRJ10DJ0R0T	RES , CHIP	0 ohm 1/16W 0% 0603
R2352	CRJ10DJ0R0T	RES , CHIP	0 ohm 1/16W 0% 0603
R2353	CRJ10DJ0R0T	RES , CHIP	0 ohm 1/16W 0% 0603
R2355	CRJ10DJ0R0T	RES , CHIP	0 ohm 1/16W 0% 0603
R2359	CRJ10DJ0R0T	RES , CHIP	0 ohm 1/16W 0% 0603
R2360	CRJ10DJ0R0T	RES , CHIP	0 ohm 1/16W 0% 0603
R2361	CRJ10DJ750T	RES , CHIP	75 ohm 1/16W 5% 0603
R2362	CRJ10DJ0R0T	RES , CHIP	0 ohm 1/16W 0% 0603
R2363	CRJ10DJ103T	RES , CHIP	10K ohm 1/16W 5% 0603
R2365	CRJ10DJ101T	RES , CHIP	100 ohm 1/16W 5% 0603
R2366	CRJ10DJ0R0T	RES , CHIP	0 ohm 1/16W 0% 0603
R2368	CRJ10DJ101T	RES , CHIP	100 ohm 1/16W 5% 0603
R2369	CRJ10DJ0R0T	RES , CHIP	0 ohm 1/16W 0% 0603
R2372	CRJ10DJ472T	RES , CHIP	4K7ohm 1/16W 5% 0603
R2373	CRJ10DJ472T	RES , CHIP	4K7ohm 1/16W 5% 0603
R2374	CRJ10DJ103T	RES , CHIP	10K ohm 1/16W 5% 0603
R2375	CRJ10DJ0R0T	RES , CHIP	0 ohm 1/16W 0% 0603
R2376	CRJ10DJ103T	RES , CHIP	10K ohm 1/16W 5% 0603
R2377	CRJ10DF1690T	RES , CHIP(1/10W, 169OHM, 1%)	1/10W, 169OHM, 1%
R2378	CRJ10DJ392T	RES , CHIP	3K9 ohm 1/16W 5% 0603
R2379	CRJ10DJ392T	RES , CHIP	3K9 ohm 1/16W 5% 0603
R2380	CRJ10DJ221T	RES , CHIP	220 ohm 1/16W 5% 0603
R2381	CRJ10DJ221T	RES , CHIP	220 ohm 1/16W 5% 0603
R2382	CRJ10DJ0R0T	RES , CHIP	0 ohm 1/16W 0% 0603
R2383	CRJ10DJ1R0T	RES , CHIP	1 ohm 1/16W 5% 0603
R2384	CRJ10DJ1R0T	RES , CHIP	1 ohm 1/16W 5% 0603
R2386	CRJ10DJ0R0T	RES , CHIP	0 ohm 1/16W 0% 0603
R2400	CRJ10DJ301T	RES , CHIP	300 ohm 1/16W 5% 0603
R2401	CRJ10DJ301T	RES , CHIP	300 ohm 1/16W 5% 0603
R2402	CRJ10DJ0R0T	RES , CHIP	0 ohm 1/16W 0% 0603
R2403	CRJ10DJ0R0T	RES , CHIP	0 ohm 1/16W 0% 0603
R2404	CRJ10DF1690T	RES , CHIP(1/10W, 169OHM, 1%)	1/10W, 169OHM, 1%
R2405	CRJ10DF1690T	RES , CHIP(1/10W, 169OHM, 1%)	1/10W, 169OHM, 1%
R2406	CRJ10DF1690T	RES , CHIP(1/10W, 169OHM, 1%)	1/10W, 169OHM, 1%
R2407	CRJ10DJ223T	RES , CHIP	22K ohm 1/16W 5% 0603
R2410	CRJ10DJ301T	RES , CHIP	300 ohm 1/16W 5% 0603
R2411	CRJ10DJ301T	RES , CHIP	300 ohm 1/16W 5% 0603
R2412	CRJ10DJ301T	RES , CHIP	300 ohm 1/16W 5% 0603

Ref. Designator	Part Number	Description	Qty
HDMI PCB ASS'Y		COP12041B	
R2416	CRJ10DJ473T	RES , CHIP	47K ohm 1/16W 5% 0603
R2417	CRJ10DJ473T	RES , CHIP	47K ohm 1/16W 5% 0603
R2418	CRJ10DJ473T	RES , CHIP	47K ohm 1/16W 5% 0603
R2419	CRJ10DJ473T	RES , CHIP	47K ohm 1/16W 5% 0603
R2420	CRJ10DJ473T	RES , CHIP	47K ohm 1/16W 5% 0603
R2421	CRJ10DJ473T	RES , CHIP	47K ohm 1/16W 5% 0603
R2000	CRJ10DJ0R0T	RES , CHIP	0 ohm 1/16W 0% 0603
R2003	CRJ10DJ102T	RES , CHIP	1K ohm 1/16W 5% 0603
R2007	CRJ10DJ511T	RES , CHIP	510 ohm 1/16W 5% 0603
R2008	CRJ10DJ0R0T	RES , CHIP	0 ohm 1/16W 0% 0603
R2009	CRJ10DJ103T	RES , CHIP	10K ohm 1/16W 5% 0603
R2010	CRJ10DJ103T	RES , CHIP	10K ohm 1/16W 5% 0603
R2011	CRJ10DJ0R0T	RES , CHIP	0 ohm 1/16W 0% 0603
R2012	CRJ10DJ470T	RES , CHIP	47 ohm 1/16W 5% 0603
R2013	CRJ10DJ103T	RES , CHIP	10K ohm 1/16W 5% 0603
R2014	CRJ10DJ103T	RES , CHIP	10K ohm 1/16W 5% 0603
R2015	CRJ10DJ103T	RES , CHIP	10K ohm 1/16W 5% 0603
R2016	CRJ10DJ473T	RES , CHIP	47K ohm 1/16W 5% 0603
R2017	CRJ10DJ103T	RES , CHIP	10K ohm 1/16W 5% 0603
R2018	CRJ10DJ470T	RES , CHIP	47 ohm 1/16W 5% 0603
R2020	CRJ10DJ472T	RES , CHIP	4K7ohm 1/16W 5% 0603
R2021	CRJ10DJ472T	RES , CHIP	4K7ohm 1/16W 5% 0603
R2022	CRJ10DJ103T	RES , CHIP	10K ohm 1/16W 5% 0603
R2023	CRJ10DJ470T	RES , CHIP	47 ohm 1/16W 5% 0603
R2025	CRJ10DJ472T	RES , CHIP	4K7ohm 1/16W 5% 0603
R2026	CRJ064IJ220T	RES , CHIP ARRAY	22 ohm 1/16W 5% CN24J220
R2027	CRJ10DJ472T	RES , CHIP	4K7ohm 1/16W 5% 0603
R2028	CRJ10DJ473T	RES , CHIP	47K ohm 1/16W 5% 0603
R2029	CRJ10DJ473T	RES , CHIP	47K ohm 1/16W 5% 0603
R2031	CRJ064IJ220T	RES , CHIP ARRAY	22 ohm 1/16W 5% CN24J220
R2032	CRJ10DJ472T	RES , CHIP	4K7ohm 1/16W 5% 0603
R2033	CRJ10DJ101T	RES , CHIP	100 ohm 1/16W 5% 0603
R2034	CRJ10DJ101T	RES , CHIP	100 ohm 1/16W 5% 0603
R2035	CRJ10DJ182T	RES , CHIP	1K8 ohm 1/16W 5% 0603
R2036	CRJ10DJ182T	RES , CHIP	1K8 ohm 1/16W 5% 0603
R2037	CRJ10DJ0R0T	RES , CHIP	0 ohm 1/16W 0% 0603
R2038	CRJ10DJ0R0T	RES , CHIP	0 ohm 1/16W 0% 0603
R2039	CRJ10DJ472T	RES , CHIP	4K7ohm 1/16W 5% 0603
R2040	CRJ10DJ472T	RES , CHIP	4K7ohm 1/16W 5% 0603
R2041	CRJ10DJ123T	RES , CHIP	12K ohm 1/16W 5% 0603
R2042	CRJ10DJ0R0T	RES , CHIP	0 ohm 1/16W 0% 0603
R2043	CRJ10DJ0R0T	RES , CHIP	0 ohm 1/16W 0% 0603
R2044	CRJ10DJ0R0T	RES , CHIP	0 ohm 1/16W 0% 0603
R2045	CRJ10DJ0R0T	RES , CHIP	0 ohm 1/16W 0% 0603
R2046	CRJ10DJ0R0T	RES , CHIP	0 ohm 1/16W 0% 0603
R2047	CRJ10DJ123T	RES , CHIP	12K ohm 1/16W 5% 0603
R2048	CRJ10DJ0R0T	RES , CHIP	0 ohm 1/16W 0% 0603
R2049	CRJ10DJ0R0T	RES , CHIP	0 ohm 1/16W 0% 0603
R2051	CRJ10DJ0R0T	RES , CHIP	0 ohm 1/16W 0% 0603
R2052	CRJ064IJ220T	RES , CHIP ARRAY	22 ohm 1/16W 5% CN24J220
R2053	CRJ10DJ472T	RES , CHIP	4K7ohm 1/16W 5% 0603
R2054	CRJ10DJ101T	RES , CHIP	100 ohm 1/16W 5% 0603
R2055	CRJ10DJ101T	RES , CHIP	100 ohm 1/16W 5% 0603
R2056	CRJ10DJ681T	RES , CHIP	680 ohm 1/16W 5% 0603
R2057	CRJ064IJ470T	RES , CHIP ARRAY	47 OHM 5% 1/16W 1005 X 4
R2058	CRJ064IJ470T	RES , CHIP ARRAY	47 OHM 5% 1/16W 1005 X 4
R2059	CRJ064IJ470T	RES , CHIP ARRAY	47 OHM 5% 1/16W 1005 X 4
R2060	CRJ064IJ470T	RES , CHIP ARRAY	47 OHM 5% 1/16W 1005 X 4
R2061	CRJ064IJ470T	RES , CHIP ARRAY	47 OHM 5% 1/16W 1005 X 4
R2062	CRJ064IJ470T	RES , CHIP ARRAY	47 OHM 5% 1/16W 1005 X 4
R2063	CRJ064IJ470T	RES , CHIP ARRAY	47 OHM 5% 1/16W 1005 X 4
R2064	CRJ064IJ470T	RES , CHIP ARRAY	47 OHM 5% 1/16W 1005 X 4
R2065	CRJ064IJ470T	RES , CHIP ARRAY	47 OHM 5% 1/16W 1005 X 4
R2066	CRJ064IJ470T	RES , CHIP ARRAY	47 OHM 5% 1/16W 1005 X 4
R2067	CRJ10DJ0R0T	RES , CHIP	0 ohm 1/16W 0% 0603
R2068	CRJ10DJ472T	RES , CHIP	4K7ohm 1/16W 5% 0603
R2069	CRJ064IJ220T	RES , CHIP ARRAY	22 OHM 5% 1/16W 1005 X 4
R2070	CRJ064IJ220T	RES , CHIP ARRAY	22 OHM 5% 1/16W 1005 X 4
R2071	CRJ10DJ472T	RES , CHIP	4K7ohm 1/16W 5% 0603
R2072	CRJ10DJ220T	RES , CHIP	22 ohm 1/16W 5% 0603
R2073	CRJ064IJ330T	RES , CHIP NETWORK(1/16W, 33ohm, 1005X4)	MNR04M0APJ330

Ref. Designator	Part Number	Description	Qty
HDMI PCB ASS'Y		COP12041B	
R2074	CRJ10DJ102T	RES , CHIP	1K ohm 1/16W 5% 0603
R2075	CRJ10DJ102T	RES , CHIP	1K ohm 1/16W 5% 0603
R2076	CRJ10DJ102T	RES , CHIP	1K ohm 1/16W 5% 0603
R2077	CRJ10DJ0R0T	RES , CHIP	0 ohm 1/16W 0% 0603
R2078	CRJ10DJ0R0T	RES , CHIP	0 ohm 1/16W 0% 0603
R2079	CRJ10DJ0R0T	RES , CHIP	0 ohm 1/16W 0% 0603
R2080	CRJ10DJ0R0T	RES , CHIP	0 ohm 1/16W 0% 0603
R2081	CRJ10DJ102T	RES , CHIP	1K ohm 1/16W 5% 0603
R2082	CRJ10DJ102T	RES , CHIP	1K ohm 1/16W 5% 0603
R2083	CRJ10DJ0R0T	RES , CHIP	0 ohm 1/16W 0% 0603
R2084	CRJ10DJ0R0T	RES , CHIP	0 ohm 1/16W 0% 0603
R2085	CRJ10DJ0R0T	RES , CHIP	0 ohm 1/16W 0% 0603
R2086	CRJ10DJ0R0T	RES , CHIP	0 ohm 1/16W 0% 0603
R2087	CRJ10DJ0R0T	RES , CHIP	0 ohm 1/16W 0% 0603
R2088	CRJ064IJ330T	RES , CHIP NETWORK(1/16W, 33ohm, 1005X4)	MNR04M0APJ330
R2089	CRJ10DJ0R0T	RES , CHIP	0 ohm 1/16W 0% 0603
R2090	CRJ10DJ0R0T	RES , CHIP	0 ohm 1/16W 0% 0603
R2091	CRJ10DJ0R0T	RES , CHIP	0 ohm 1/16W 0% 0603
R2092	CRJ10DJ0R0T	RES , CHIP	0 ohm 1/16W 0% 0603
R2093	CRJ10DJ0R0T	RES , CHIP	0 ohm 1/16W 0% 0603
R2094	CRJ10DF75R0T	RES , CHIP 1% 75 OHM	75 ohm 1/16W 1% 0603
R2095	CRJ10DJ0R0T	RES , CHIP	0 ohm 1/16W 0% 0603
R2096	CRJ10DJ0R0T	RES , CHIP	0 ohm 1/16W 0% 0603
R2097	CRJ10DJ0R0T	RES , CHIP	0 ohm 1/16W 0% 0603
R2098	CRJ10DF75R0T	RES , CHIP 1% 75 OHM	75 ohm 1/16W 1% 0603
R2100	CRJ10DJ103T	RES , CHIP	10K ohm 1/16W 5% 0603
R2101	CRJ10DJ750T	RES , CHIP	75 ohm 1/16W 5% 0603
R2103	CRJ10DJ0R0T	RES , CHIP	0 ohm 1/16W 0% 0603
R2104	CRJ10DJ0R0T	RES , CHIP	0 ohm 1/16W 0% 0603
R2105	CRJ10DJ0R0T	RES , CHIP	0 ohm 1/16W 0% 0603
R2106	CRJ10DJ0R0T	RES , CHIP	0 ohm 1/16W 0% 0603
R2107	CRJ10DJ103T	RES , CHIP	10K ohm 1/16W 5% 0603
R2108	CRJ10DJ0R0T	RES , CHIP	0 ohm 1/16W 0% 0603
R2109	CRJ10DF57R6T	RES , CHIP(57.6 ohm 1/16W 1% 1608)	57.6 ohm 1/16W 1% 0603
R2110	CRJ10DJ0R0T	RES , CHIP	0 ohm 1/16W 0% 0603
R2111	CRJ10DJ200T	RES , CHIP(1/10W, 20OHM,1608)	1/10W, 20OHM,1608
R2112	CRJ10DJ200T	RES , CHIP(1/10W, 20OHM,1608)	1/10W, 20OHM,1608
R2113	CRJ10DJ0R0T	RES , CHIP	0 ohm 1/16W 0% 0603
R2114	CRJ10DJ0R0T	RES , CHIP	0 ohm 1/16W 0% 0603
R2115	CRJ10DJ0R0T	RES , CHIP	0 ohm 1/16W 0% 0603
R2116	CRJ10DJ0R0T	RES , CHIP	0 ohm 1/16W 0% 0603
R2117	CRJ10DJ0R0T	RES , CHIP	0 ohm 1/16W 0% 0603
R2118	CRJ10DJ0R0T	RES , CHIP	0 ohm 1/16W 0% 0603
R2119	CRJ10DF75R0T	RES , CHIP 1% 75 OHM	75 ohm 1/16W 1% 0603
R2120	CRJ10DJ200T	RES , CHIP(1/10W, 20OHM,1608)	1/10W, 20OHM,1608
R2121	CRJ10DJ0R0T	RES , CHIP	0 ohm 1/16W 0% 0603
R2122	CRJ10DJ103T	RES , CHIP	10K ohm 1/16W 5% 0603
R2123	CRJ10DJ0R0T	RES , CHIP	0 ohm 1/16W 0% 0603
R2124	CRJ10DJ750T	RES , CHIP	75 ohm 1/16W 5% 0603
R2125	CRJ10DJ0R0T	RES , CHIP	0 ohm 1/16W 0% 0603
R2126	CRJ10DF57R6T	RES , CHIP(57.6 ohm 1/16W 1% 1608)	57.6 ohm 1/16W 1% 0603
R2127	CRJ10DJ0R0T	RES , CHIP	0 ohm 1/16W 0% 0603
R2128	CRJ10DJ103T	RES , CHIP	10K ohm 1/16W 5% 0603
R2129	CRJ10DJ0R0T	RES , CHIP	0 ohm 1/16W 0% 0603
R2130	CRJ10DF75R0T	RES , CHIP 1% 75 OHM	75 ohm 1/16W 1% 0603
R2131	CRJ10DJ200T	RES , CHIP(1/10W, 20OHM,1608)	20 ohm 1/16W 5% 0603
R2133	CRJ064IJ330T	RES , CHIP NETWORK(1/16W, 33ohm, 1005X4)	MNR04M0APJ330
R2134	CRJ064IJ220T	RES , CHIP ARRAY	22 OHM 5% 1/16W 1005 X 4
R2135	CRJ064IJ220T	RES , CHIP ARRAY	22 OHM 5% 1/16W 1005 X 4
R2136	CRJ064IJ220T	RES , CHIP ARRAY	22 OHM 5% 1/16W 1005 X 4
R2137	CRJ064IJ220T	RES , CHIP ARRAY	22 OHM 5% 1/16W 1005 X 4
R2138	CRJ064IJ220T	RES , CHIP ARRAY	22 OHM 5% 1/16W 1005 X 4
R2139	CRJ064IJ220T	RES , CHIP ARRAY	22 OHM 5% 1/16W 1005 X 4
R2140	CRJ064IJ220T	RES , CHIP ARRAY	22 OHM 5% 1/16W 1005 X 4
R2141	CRJ064IJ220T	RES , CHIP ARRAY	22 OHM 5% 1/16W 1005 X 4
R2142	CRJ064IJ220T	RES , CHIP ARRAY	22 OHM 5% 1/16W 1005 X 4
R2143	CRJ064IJ220T	RES , CHIP ARRAY	22 OHM 5% 1/16W 1005 X 4
R2144	CRJ10DF75R0T	RES , CHIP 1% 75 OHM	75 OHM, 1%
R2145	CRJ10DJ200T	RES , CHIP(1/10W, 20OHM,1608)	1/10W, 20OHM,1608
R2146	CRJ062IJ330T	RES , CHIP NETWORK(1/16W, 33ohm, 1005X2)	MNR02M0APJ330
R2147	CRJ10DF75R0T	RES , CHIP 1% 75 OHM	75 OHM, 1%

Ref. Designator	Part Number	Description		Qty
HDMI PCB ASS'Y		COP12041B		
R2148	CRJ10DJ200T	RES , CHIP(1/10W, 20OHM,1608)	1/10W, 20OHM,1608	1
R2149	CRJ064IJ330T	RES , CHIP NETWORK(1/16W, 33ohm, 1005X4)	MNR04M0APJ330	1
R2151	CRJ10DJ330T	RES , CHIP	1608 SIZE	1
R2152	CRJ10DJ200T	RES , CHIP(1/10W, 20OHM,1608)	1/10W, 20OHM,1608	1
R2153	CRJ10DJ200T	RES , CHIP(1/10W, 20OHM,1608)	1/10W, 20OHM,1608	1
R2154	CRJ064IJ330T	RES , CHIP NETWORK(1/16W, 33ohm, 1005X4)	MNR04M0APJ330	1
R2155	CRJ064IJ220T	RES , CHIP ARRAY	22 OHM 5% 1/16W 1005 X 4	1
R2156	CRJ064IJ220T	RES , CHIP ARRAY	22 OHM 5% 1/16W 1005 X 4	1
R2157	CRJ064IJ220T	RES , CHIP ARRAY	22 OHM 5% 1/16W 1005 X 4	1
R2158	CRJ064IJ220T	RES , CHIP ARRAY	22 OHM 5% 1/16W 1005 X 4	1
R2159	CRJ064IJ220T	RES , CHIP ARRAY	22 OHM 5% 1/16W 1005 X 4	1
R2160	CRJ064IJ220T	RES , CHIP ARRAY	22 OHM 5% 1/16W 1005 X 4	1
R2161	CRJ064IJ220T	RES , CHIP ARRAY	22 OHM 5% 1/16W 1005 X 4	1
R2162	CRJ064IJ220T	RES , CHIP ARRAY	22 OHM 5% 1/16W 1005 X 4	1
R2163	CRJ064IJ220T	RES , CHIP ARRAY	22 OHM 5% 1/16W 1005 X 4	1
R2164	CRJ064IJ220T	RES , CHIP ARRAY	22 OHM 5% 1/16W 1005 X 4	1
R2165	CRJ10DJ220T	RES , CHIP	22 ohm 1/16W 5% 0603	1
R2166	CRJ10DJ200T	RES , CHIP(1/10W, 20OHM,1608)	1/10W, 20OHM,1608	1
R2167	CRJ10DF57R6T	RES , CHIP(57.6 ohm 1/16W 1% 1608)	57.6 ohm 1/16W 1% 0603	1
R2169	CRJ10DF57R6T	RES , CHIP(57.6 ohm 1/16W 1% 1608)	57.6 ohm 1/16W 1% 0603	1
R2170	CRJ10DJ103T	RES , CHIP	10K ohm 1/16W 5% 0603	1
R2171	CRJ062IJ330T	RES , CHIP NETWORK(1/16W, 33ohm, 1005X2)	33 ohm 1/16W 5% CN22J330	1
R2172	CRJ10DJ0R0T	RES , CHIP	0 ohm 1/16W 0% 0603	1
R2173	CRJ10DJ103T	RES , CHIP	10K ohm 1/16W 5% 0603	1
R2174	CRJ064IJ330T	RES , CHIP NETWORK(1/16W, 33ohm, 1005X4)	33 ohm 1/16W 5% CN24J330	1
R2176	CRJ10DJ103T	RES , CHIP	10K ohm 1/16W 5% 0603	1
R2177	CRJ10DJ103T	RES , CHIP	10K ohm 1/16W 5% 0603	1
R2178	CRJ10DJ103T	RES , CHIP	10K ohm 1/16W 5% 0603	1
R2180	CRJ10DJ103T	RES , CHIP	10K ohm 1/16W 5% 0603	1
R2181	CRJ064IJ330T	RES , CHIP NETWORK(1/16W, 33ohm, 1005X4)	33 ohm 1/16W 5% CN24J330	1
R2182	CRJ10DJ103T	RES , CHIP	10K ohm 1/16W 5% 0603	1
R2183	CRJ10DJ103T	RES , CHIP	10K ohm 1/16W 5% 0603	1
R2184	CRJ10DJ103T	RES , CHIP	10K ohm 1/16W 5% 0603	1
R2185	CRJ10DJ103T	RES , CHIP	10K ohm 1/16W 5% 0603	1
R2186	CRJ10DJ103T	RES , CHIP	10K ohm 1/16W 5% 0603	1
R2187	CRJ10DJ103T	RES , CHIP	10K ohm 1/16W 5% 0603	1
R2189	CRJ10DJ103T	RES , CHIP	10K ohm 1/16W 5% 0603	1
R2190	CRJ10DJ103T	RES , CHIP	10K ohm 1/16W 5% 0603	1
R2191	CRJ062IJ330T	RES , CHIP NETWORK(1/16W, 33ohm, 1005X2)	33 ohm 1/16W 5% CN22J330	1
R2192	CRJ10DJ103T	RES , CHIP	10K ohm 1/16W 5% 0603	1
R2193	CRJ10DJ103T	RES , CHIP	10K ohm 1/16W 5% 0603	1
R2194	CRJ10DJ103T	RES , CHIP	10K ohm 1/16W 5% 0603	1
R2195	CRJ10DJ103T	RES , CHIP	10K ohm 1/16W 5% 0603	1
R2198	CRJ10DJ103T	RES , CHIP	10K ohm 1/16W 5% 0603	1
R2199	CRJ10DJ103T	RES , CHIP	10K ohm 1/16W 5% 0603	1
R2200	CRJ064IJ330T	RES , CHIP NETWORK(1/16W, 33ohm, 1005X4)	33 ohm 1/16W 5% CN24J330	1
R2201	CRJ10DJ103T	RES , CHIP	10K ohm 1/16W 5% 0603	1
R2202	CRJ064IJ330T	RES , CHIP NETWORK(1/16W, 33ohm, 1005X4)	33 ohm 1/16W 5% CN24J330	1
R2203	CRJ062IJ330T	RES , CHIP NETWORK(1/16W, 33ohm, 1005X2)	33 ohm 1/16W 5% CN22J330	1
R2204	CRJ064IJ330T	RES , CHIP NETWORK(1/16W, 33ohm, 1005X4)	33 ohm 1/16W 5% CN24J330	1
R2205	CRJ062IJ330T	RES , CHIP NETWORK(1/16W, 33ohm, 1005X2)	33 ohm 1/16W 5% CN22J330	1
R2206	CRJ062IJ330T	RES , CHIP NETWORK(1/16W, 33ohm, 1005X2)	33 ohm 1/16W 5% CN22J330	1
R2207	CRJ062IJ330T	RES , CHIP NETWORK(1/16W, 33ohm, 1005X2)	33 ohm 1/16W 5% CN22J330	1
R2209	CRJ064IJ220T	RES , CHIP ARRAY	22 OHM 5% 1/16W 1005 X 4	1
R2210	CRJ064IJ220T	RES , CHIP ARRAY	22 OHM 5% 1/16W 1005 X 4	1
R2211	CRJ064IJ220T	RES , CHIP ARRAY	22 OHM 5% 1/16W 1005 X 4	1
R2212	CRJ064IJ220T	RES , CHIP ARRAY	22 OHM 5% 1/16W 1005 X 4	1
R2213	CRJ064IJ220T	RES , CHIP ARRAY	22 OHM 5% 1/16W 1005 X 4	1
R2214	CRJ064IJ220T	RES , CHIP ARRAY	22 OHM 5% 1/16W 1005 X 4	1
R2215	CRJ064IJ220T	RES , CHIP ARRAY	22 OHM 5% 1/16W 1005 X 4	1
R2216	CRJ064IJ220T	RES , CHIP ARRAY	22 OHM 5% 1/16W 1005 X 4	1
R2217	CRJ064IJ220T	RES , CHIP ARRAY	22 OHM 5% 1/16W 1005 X 4	1
R2218	CRJ064IJ220T	RES , CHIP ARRAY	22 OHM 5% 1/16W 1005 X 4	1
R2219	CRJ064IJ220T	RES , CHIP ARRAY	22 OHM 5% 1/16W 1005 X 4	1
R2220	CRJ064IJ220T	RES , CHIP ARRAY	22 OHM 5% 1/16W 1005 X 4	1
R2221	CRJ064IJ220T	RES , CHIP ARRAY	22 OHM 5% 1/16W 1005 X 4	1
R2222	CRJ064IJ220T	RES , CHIP ARRAY	22 OHM 5% 1/16W 1005 X 4	1
R2223	CRJ064IJ220T	RES , CHIP ARRAY	22 OHM 5% 1/16W 1005 X 4	1
R2224	CRJ064IJ220T	RES , CHIP ARRAY	22 OHM 5% 1/16W 1005 X 4	1
R2225	CRJ064IJ220T	RES , CHIP ARRAY	22 OHM 5% 1/16W 1005 X 4	1
R2227	CRJ10DJ0R0T	RES , CHIP	0 ohm 1/16W 0% 0603	1

Ref. Designator	Part Number	Description	Qty
HDMI PCB ASS'Y		COP12041B	
R2229	CRJ10DJ220T	RES , CHIP	22 ohm 1/16W 5% 0603
R2231	CRJ064IJ220T	RES , CHIP ARRAY	22 OHM 5% 1/16W 1005 X 4
R2232	CRJ064IJ220T	RES , CHIP ARRAY	22 OHM 5% 1/16W 1005 X 4
R2233	CRJ064IJ220T	RES , CHIP ARRAY	22 OHM 5% 1/16W 1005 X 4
R2234	CRJ064IJ220T	RES , CHIP ARRAY	22 OHM 5% 1/16W 1005 X 4
R2236	CRJ064IJ220T	RES , CHIP ARRAY	22 OHM 5% 1/16W 1005 X 4
R2237	CRJ064IJ220T	RES , CHIP ARRAY	22 OHM 5% 1/16W 1005 X 4
R2238	CRJ064IJ220T	RES , CHIP ARRAY	22 OHM 5% 1/16W 1005 X 4
R2239	CRJ064IJ220T	RES , CHIP ARRAY	22 OHM 5% 1/16W 1005 X 4
R2240	CRJ10DJ103T	RES , CHIP	10K ohm 1/16W 5% 0603
R2241	CRJ10DJ0R0T	RES , CHIP	0 ohm 1/16W 0% 0603
R2245	CRJ064IJ220T	RES , CHIP ARRAY	22 OHM 5% 1/16W 1005 X 4
R2247	CRJ10DJ0R0T	RES , CHIP	0 ohm 1/16W 0% 0603
R2248	CRJ10DJ750T	RES , CHIP	75 ohm 1/16W 5% 0603
R2249	CRJ10DJ0R0T	RES , CHIP	0 ohm 1/16W 0% 0603
R2250	CRJ10DJ0R0T	RES , CHIP	0 ohm 1/16W 0% 0603
R2251	CRJ10DJ0R0T	RES , CHIP	0 ohm 1/16W 0% 0603
R2252	CRJ10DJ103T	RES , CHIP	10K ohm 1/16W 5% 0603
R2253	CRJ10DJ750T	RES , CHIP	75 ohm 1/16W 5% 0603
R2254	CRJ10DJ301T	RES , CHIP	300 ohm 1/16W 5% 0603
R2255	CRJ10DJ112T	RES , CHIP	1.1K ohm 1/16W 5% 0603
R2256	CRJ10DJ0R0T	RES , CHIP	0 ohm 1/16W 0% 0603
R2257	CRJ10DJ301T	RES , CHIP	300 ohm 1/16W 5% 0603
R2258	CRJ10DJ301T	RES , CHIP	300 ohm 1/16W 5% 0603
R2259	CRJ10DJ0R0T	RES , CHIP	0 ohm 1/16W 0% 0603
R2260	CRJ10DJ0R0T	RES , CHIP	0 ohm 1/16W 0% 0603
R2261	CRJ10DJ301T	RES , CHIP	300 ohm 1/16W 5% 0603
R2262	CRJ10DJ301T	RES , CHIP	300 ohm 1/16W 5% 0603
R2263	CRJ10DJ0R0T	RES , CHIP	0 ohm 1/16W 0% 0603
R2264	CRJ10DJ0R0T	RES , CHIP	0 ohm 1/16W 0% 0603
R2265	CRJ10DJ301T	RES , CHIP	300 ohm 1/16W 5% 0603
R2389	CRJ10DJ472T	RES , CHIP	4K7ohm 1/16W 5% 0603
R2390	CRJ10DJ472T	RES , CHIP	4K7ohm 1/16W 5% 0603
R2391	CRJ10DJ0R0T	RES , CHIP	0 ohm 1/16W 0% 0603
R2392	CRJ10DJ0R0T	RES , CHIP	0 ohm 1/16W 0% 0603
R2393	CRJ10DJ0R0T	RES , CHIP	0 ohm 1/16W 0% 0603
R2394	CRJ10DJ0R0T	RES , CHIP	0 ohm 1/16W 0% 0603
R2422	CRJ10DJ511T	RES , CHIP	510 ohm 1/16W 5% 0603
R2423	CRJ10DJ103T	RES , CHIP	10K ohm 1/16W 5% 0603
R2424	CRJ10DJ102T	RES , CHIP	1K ohm 1/16W 5% 0603
V2000	CRVEGA10402V05AH	VARISTER , CHIP(5V, 0.2PF, 1005, EGA)	EGA10402V05AH
V2001	CRVEGA10603V12A1B	VARISTER , CHIP(12V, 0.2PF, 1608, EGA)	EGA10603V12A1-B
V2002	CRVEGA10603V12A1B	VARISTER , CHIP(12V, 0.2PF, 1608, EGA)	EGA10603V12A1-B
V2003	CRVEGA10402V05AH	VARISTER , CHIP(5V, 0.2PF, 1005, EGA)	EGA10402V05AH
V2004	CRVEGA10402V05AH	VARISTER , CHIP(5V, 0.2PF, 1005, EGA)	EGA10402V05AH
V2005	CRVEGA10402V05AH	VARISTER , CHIP(5V, 0.2PF, 1005, EGA)	EGA10402V05AH
V2006	CRVEGA10402V05AH	VARISTER , CHIP(5V, 0.2PF, 1005, EGA)	EGA10402V05AH
V2007	CRVEGA10402V05AH	VARISTER , CHIP(5V, 0.2PF, 1005, EGA)	EGA10402V05AH
V2008	CRVEGA10402V05AH	VARISTER , CHIP(5V, 0.2PF, 1005, EGA)	EGA10402V05AH
V2009	CRVEGA10603V12A1B	VARISTER , CHIP(12V, 0.2PF, 1608, EGA)	EGA10603V12A1-B
V2010	CRVEGA10603V12A1B	VARISTER , CHIP(12V, 0.2PF, 1608, EGA)	EGA10603V12A1-B
V2011	CRVEGA10603V12A1B	VARISTER , CHIP(12V, 0.2PF, 1608, EGA)	EGA10603V12A1-B
V2012	CRVEGA10603V12A1B	VARISTER , CHIP(12V, 0.2PF, 1608, EGA)	EGA10603V12A1-B
V2013	CRVEGA10402V05AH	VARISTER , CHIP(5V, 0.2PF, 1005, EGA)	EGA10402V05AH
V2014	CRVEGA10402V05AH	VARISTER , CHIP(5V, 0.2PF, 1005, EGA)	EGA10402V05AH
V2015	CRVEGA10402V05AH	VARISTER , CHIP(5V, 0.2PF, 1005, EGA)	EGA10402V05AH
V2016	CRVEGA10603V12A1B	VARISTER , CHIP(12V, 0.2PF, 1608, EGA)	EGA10603V12A1-B
V2017	CRVEGA10603V12A1B	VARISTER , CHIP(12V, 0.2PF, 1608, EGA)	EGA10603V12A1-B
V2018	CRVEGA10402V05AH	VARISTER , CHIP(5V, 0.2PF, 1005, EGA)	EGA10402V05AH
V2019	CRVEGA10402V05AH	VARISTER , CHIP(5V, 0.2PF, 1005, EGA)	EGA10402V05AH
V2020	CRVEGA10402V05AH	VARISTER , CHIP(5V, 0.2PF, 1005, EGA)	EGA10402V05AH
V2021	CRVEGA10402V05AH	VARISTER , CHIP(5V, 0.2PF, 1005, EGA)	EGA10402V05AH
V2022	CRVEGA10402V05AH	VARISTER , CHIP(5V, 0.2PF, 1005, EGA)	EGA10402V05AH
V2023	CRVEGA10402V05AH	VARISTER , CHIP(5V, 0.2PF, 1005, EGA)	EGA10402V05AH
V2024	CRVEGA10402V05AH	VARISTER , CHIP(5V, 0.2PF, 1005, EGA)	EGA10402V05AH
V2025	CRVEGA10402V05AH	VARISTER , CHIP(5V, 0.2PF, 1005, EGA)	EGA10402V05AH
V2026	CRVEGA10402V05AH	VARISTER , CHIP(5V, 0.2PF, 1005, EGA)	EGA10402V05AH
V2027	CRVEGA10402V05AH	VARISTER , CHIP(5V, 0.2PF, 1005, EGA)	EGA10402V05AH
V2028	CRVEGA10402V05AH	VARISTER , CHIP(5V, 0.2PF, 1005, EGA)	EGA10402V05AH
V2029	CRVEGA10402V05AH	VARISTER , CHIP(5V, 0.2PF, 1005, EGA)	EGA10402V05AH
V2030	CRVEGA10402V05AH	VARISTER , CHIP(5V, 0.2PF, 1005, EGA)	EGA10402V05AH

Ref. Designator	Part Number	Description	Qty
HDMI PCB ASS'Y		COP12041B	
V2031	CRVEGA10402V05AH	VARISTER , CHIP(5V, 0.2PF, 1005, EGA)	EGA10402V05AH 1
V2032	CRVEGA10402V05AH	VARISTER , CHIP(5V, 0.2PF, 1005, EGA)	EGA10402V05AH 1
V2033	CRVEGA10402V05AH	VARISTER , CHIP(5V, 0.2PF, 1005, EGA)	EGA10402V05AH 1
V2034	CRVEGA10402V05AH	VARISTER , CHIP(5V, 0.2PF, 1005, EGA)	EGA10402V05AH 1
V2035	CRVEGA10402V05AH	VARISTER , CHIP(5V, 0.2PF, 1005, EGA)	EGA10402V05AH 1
V2036	CRVEGA10402V05AH	VARISTER , CHIP(5V, 0.2PF, 1005, EGA)	EGA10402V05AH 1
V2038	CRVEGA10603V12A1B	VARISTER , CHIP(12V, 0.2PF, 1608, EGA)	EGA10603V12A1-B 1
V2039	CRVEGA10402V05AH	VARISTER , CHIP(5V, 0.2PF, 1005, EGA)	EGA10402V05AH 1
V2040	CRVEGA10402V05AH	VARISTER , CHIP(5V, 0.2PF, 1005, EGA)	EGA10402V05AH 1
V2041	CRVEGA10402V05AH	VARISTER , CHIP(5V, 0.2PF, 1005, EGA)	EGA10402V05AH 1
V2042	CRVEGA10402V05AH	VARISTER , CHIP(5V, 0.2PF, 1005, EGA)	EGA10402V05AH 1
V2043	CRVEGA10402V05AH	VARISTER , CHIP(5V, 0.2PF, 1005, EGA)	EGA10402V05AH 1
V2044	CRVEGA10402V05AH	VARISTER , CHIP(5V, 0.2PF, 1005, EGA)	EGA10402V05AH 1
V2045	CRVEGA10402V05AH	VARISTER , CHIP(5V, 0.2PF, 1005, EGA)	EGA10402V05AH 1
V2046	CRVEGA10402V05AH	VARISTER , CHIP(5V, 0.2PF, 1005, EGA)	EGA10402V05AH 1
V2047	CRVEGA10402V05AH	VARISTER , CHIP(5V, 0.2PF, 1005, EGA)	EGA10402V05AH 1
V2048	CRVEGA10402V05AH	VARISTER , CHIP(5V, 0.2PF, 1005, EGA)	EGA10402V05AH 1
V2049	CRVEGA10402V05AH	VARISTER , CHIP(5V, 0.2PF, 1005, EGA)	EGA10402V05AH 1
V2050	CRVEGA10603V12A1B	VARISTER , CHIP(12V, 0.2PF, 1608, EGA)	EGA10603V12A1-B 1
V2051	CRVEGA10603V12A1B	VARISTER , CHIP(12V, 0.2PF, 1608, EGA)	EGA10603V12A1-B 1
V2052	CRVEGA10603V12A1B	VARISTER , CHIP(12V, 0.2PF, 1608, EGA)	EGA10603V12A1-B 1
V2053	CRVEGA10603V12A1B	VARISTER , CHIP(12V, 0.2PF, 1608, EGA)	EGA10603V12A1-B 1
V2055	CRVEGA10603V12A1B	VARISTER , CHIP(12V, 0.2PF, 1608, EGA)	EGA10603V12A1-B 1
V2037	CRVEGA10603V12A1B	VARISTER , CHIP(12V, 0.2PF, 1608, EGA)	EGA10603V12A1-B 1
V2054	CRVEGA10603V12A1B	VARISTER , CHIP(12V, 0.2PF, 1608, EGA)	EGA10603V12A1-B 1
<i>Miscellaneous</i>			
S2000	CST1A024ZT	SW , TACT	1
X2000	COX07372E120TF	X-TAL , HC-49/S, (7.3728MHz 12pF ,WOOIN)	1
X2001	COX28322E180TF	CRYSTAL(HC-49/S.ATS)	1
	CHD1A012R	SCREW , SPECIAL	1
	CMY2A223	HEAT SINK	1
X2002	COX19660E330S	X-TAL, CHIP, 19.6608 MHz (33P)	19.6608MHz HC-49/SMD 33PF 1
BD2002	CLZ9R010Z	BEAD , FERRITE (FCM2012KF-121T08 , 120 OHM)	FCM2012KF-121T08 120ohm 2012 1
BD2003	CLZ9R010Z	BEAD , FERRITE (FCM2012KF-121T08 , 120 OHM)	FCM2012KF-121T08 120ohm 2012 1
BD2004	CLZ9R010Z	BEAD , FERRITE (FCM2012KF-121T08 , 120 OHM)	FCM2012KF-121T08 120ohm 2012 1
BD2008	CLZ9R010Z	BEAD , FERRITE (FCM2012KF-121T08 , 120 OHM)	FCM2012KF-121T08 120ohm 2012 1
BD2009	CLZ9R010Z	BEAD , FERRITE (FCM2012KF-121T08 , 120 OHM)	FCM2012KF-121T08 120ohm 2012 1
BD2010	CLZ9R010Z	BEAD , FERRITE (FCM2012KF-121T08 , 120 OHM)	FCM2012KF-121T08 120ohm 2012 1
F2001	CRTNANOSMDC050F	SW , POLY (RESETTABLE 0.5A 3216)	NANO SMDC050F+TYCO 1
F2002	CRTNANOSMDC050F	SW , POLY (RESETTABLE 0.5A 3216)	NANO SMDC050F+TYCO 1
JA2006	CJJ9H004Z	JACK , HDMI GOLD	YKF45-7043N 1
JA2007	CJJ9H004Z	JACK , HDMI GOLD	YKF45-7043N 1
JA2008	CJJ9H004Z	JACK , HDMI GOLD	YKF45-7043N 1
JA2009	CJJ9H004Z	JACK , HDMI GOLD	YKF45-7043N 1
JA2010	CJJ9H004Z	JACK , HDMI GOLD	YKF45-7043N 1
L2000	BLZ9R004Z	BEAD CHIP 90 OHM (2012 SIZE)	ACM2012H-900 1
L2001	BLZ9R004Z	BEAD CHIP 90 OHM (2012 SIZE)	ACM2012H-900 1
L2002	BLZ9R004Z	BEAD CHIP 90 OHM (2012 SIZE)	ACM2012H-900 1
L2003	BLZ9R004Z	BEAD CHIP 90 OHM (2012 SIZE)	ACM2012H-900 1
	CHD1A012R	SCREW , SPECIAL	1
	CMY2A223	HEAT SINK	1
F2000	CRTNANOSMDC150F2	SW , POLY(RESETTABLE 1.5A 0.08 OHM 0.6W 3216)	NANOSMDC150F-2 , TYCO RAYCHEM 1
BD2005	CLZ9R010Z	BEAD , FERRITE (FCM2012KF-121T08 , 120 OHM)	1
BD2006	CLZ91002Z	FERRITE , CHIP BEAD(120ohm, 3216)	HCB3216KF-121T50 1
BD2007	CLZ91002Z	FERRITE , CHIP BEAD(120ohm, 3216)	HCB3216KF-121T50 1
BD2011	CLZ9R010Z	BEAD , FERRITE (FCM2012KF-121T08 , 120 OHM)	FCM2012KF-121T08 120ohm 2012 1
BD2012	CLZ9R010Z	BEAD , FERRITE (FCM2012KF-121T08 , 120 OHM)	FCM2012KF-121T08 120ohm 2012 1
BD2014	CLZ9R010Z	BEAD , FERRITE (FCM2012KF-121T08 , 120 OHM)	FCM2012KF-121T08 120ohm 2012 1
BD2015	CLZ9R010Z	BEAD , FERRITE (FCM2012KF-121T08 , 120 OHM)	FCM2012KF-121T08 120ohm 2012 1
BD2016	CLZ9R010Z	BEAD , FERRITE (FCM2012KF-121T08 , 120 OHM)	FCM2012KF-121T08 120ohm 2012 1
BD2017	CLZ9R010Z	BEAD , FERRITE (FCM2012KF-121T08 , 120 OHM)	FCM2012KF-121T08 120ohm 2012 1
BD2018	CLZ9R010Z	BEAD , FERRITE (FCM2012KF-121T08 , 120 OHM)	FCM2012KF-121T08 120ohm 2012 1
BD2019	CLZ9R010Z	BEAD , FERRITE (FCM2012KF-121T08 , 120 OHM)	FCM2012KF-121T08 120ohm 2012 1
BD2020	CLZ9R010Z	BEAD , FERRITE (FCM2012KF-121T08 , 120 OHM)	FCM2012KF-121T08 120ohm 2012 1
BD2021	CLZ9R010Z	BEAD , FERRITE (FCM2012KF-121T08 , 120 OHM)	FCM2012KF-121T08 120ohm 2012 1
BD2022	CLZ9R010Z	BEAD , FERRITE (FCM2012KF-121T08 , 120 OHM)	FCM2012KF-121T08 120ohm 2012 1
BD2023	CLZ9R010Z	BEAD , FERRITE (FCM2012KF-121T08 , 120 OHM)	FCM2012KF-121T08 120ohm 2012 1
BD2024	CLZ9R010Z	BEAD , FERRITE (FCM2012KF-121T08 , 120 OHM)	FCM2012KF-121T08 120ohm 2012 1
BD2025	CLZ9R010Z	BEAD , FERRITE (FCM2012KF-121T08 , 120 OHM)	FCM2012KF-121T08 120ohm 2012 1

Ref. Designator	Part Number	Description		Qty
HDMI PCB ASS'Y		COP12041B		
BD2026	CLZ9R010Z	BEAD , FERRITE (FCM2012KF-121T08 , 120 OHM)	FCM2012KF-121T08 120ohm 2012	1
BD2027	CLZ9R010Z	BEAD , FERRITE (FCM2012KF-121T08 , 120 OHM)	FCM2012KF-121T08 120ohm 2012	1
BD2028	CLZ9R010Z	BEAD , FERRITE (FCM2012KF-121T08 , 120 OHM)	FCM2012KF-121T08 120ohm 2012	1
BD2029	CLZ9R010Z	BEAD , FERRITE (FCM2012KF-121T08 , 120 OHM)	FCM2012KF-121T08 120ohm 2012	1
BD2030	CLZ9R010Z	BEAD , FERRITE (FCM2012KF-121T08 , 120 OHM)	FCM2012KF-121T08 120ohm 2012	1
BD2031	CLZ9R010Z	BEAD , FERRITE (FCM2012KF-121T08 , 120 OHM)	FCM2012KF-121T08 120ohm 2012	1
BD2032	CLZ9R010Z	BEAD , FERRITE (FCM2012KF-121T08 , 120 OHM)	FCM2012KF-121T08 120ohm 2012	1
BD2033	CLZ9R010Z	BEAD , FERRITE (FCM2012KF-121T08 , 120 OHM)	FCM2012KF-121T08 120ohm 2012	1
BD2034	CLZ91002Z	FERRITE , CHIP BEAD(120ohm, 3216)	HCB3216KF-121T50	1
BD2035	CLZ9R010Z	BEAD , FERRITE (FCM2012KF-121T08 , 120 OHM)	FCM2012KF-121T08 120ohm 2012	1
BD2036	CLZ9R010Z	BEAD , FERRITE (FCM2012KF-121T08 , 120 OHM)	FCM2012KF-121T08 120ohm 2012	1
BD2037	CLZ9R010Z	BEAD , FERRITE (FCM2012KF-121T08 , 120 OHM)	FCM2012KF-121T08 120ohm 2012	1
BD2038	CLZ9R010Z	BEAD , FERRITE (FCM2012KF-121T08 , 120 OHM)	FCM2012KF-121T08 120ohm 2012	1
BD2040	CLZ9R010Z	BEAD , FERRITE (FCM2012KF-121T08 , 120 OHM)	FCM2012KF-121T08 120ohm 2012	1
BD2041	CLZ9R010Z	BEAD , FERRITE (FCM2012KF-121T08 , 120 OHM)	FCM2012KF-121T08 120ohm 2012	1
BD2042	CLZ91002Z	FERRITE , CHIP BEAD(120ohm, 3216)	HCB3216KF-121T50	1
BD2043	CLZ9R010Z	BEAD , FERRITE (FCM2012KF-121T08 , 120 OHM)	FCM2012KF-121T08 120ohm 2012	1
JA2000	CJJ2D008Z	EP-1401A		1
JA2001	CJJ2D008Z	EP-1401A		1
JA2002	CJJ2D008Z	EP-1401A		1
JA2003	CJJ2D008Z	EP-1401A		1
JA2004	CJJ2D008Z	EP-1401A		1
JA2005	CJJ2D008Z	EP-1401A		1
N2000	CJP17GB116ZY	GF120-17S-LS 1.25mm 17P	(1.25mm pitch connector FFC/FPC Series)	1
N2001	CJP11GB116ZY	GF120-11S-LS 1.25mm 11P	(1.25mm pitch connector FFC/FPC Series)	1
N2002	CJP29GB116ZY	GF120-29S-LS 1.25mm 29P	(1.25mm pitch connector FFC/FPC Series)	1
N2003	CJP40GA227ZB	PAS2252-2001A46B1BA		1
N2007	CWB1B004080GN	4P WIRE ASS'Y(80MM, 2.0MM)		1
P2002	CJP04GA228ZB	PIN HEADER(4P, 2.54mm, FAM150A-04G002-6T)	FAM150	1
P2005	CJP07GB03ZY	5268-07A 2.5mm 7P WHT ANGLE		1
P2006	CJP04GB48ZW	GIL-S-04P-S2L2-EF 4P	(2.00mm pitch wire to board connector)	1
P2007	CJP05GB48ZW	GIL-S-05P-S2L2-EF 5P	(2.00mm pitch wire to board connector)	1
P2020	CJP02GB03ZY	5268-02A 2.5mm 2P WHT ANGLE	YEONHO YM025 SERIES	1
PROCESSOR PCB ASS'Y		COP12042B		
<i>Capacitors</i>				1
C1150	CCUS1H101JA	CAP , CHIP	100PF 50V J	1
C1151	CCUS1H101JA	CAP , CHIP	100PF 50V J	1
C1152	CCUS1H101JA	CAP , CHIP	100PF 50V J	1
C1155	CCUS1H101JA	CAP , CHIP	100PF 50V J	1
C1156	CCUS1H101JA	CAP , CHIP	100PF 50V J	1
C1157	CCUS1H101JA	CAP , CHIP	100PF 50V J	1
C1158	CCUS1H101JA	CAP , CHIP	100PF 50V J	1
C1159	CCUS1H101JA	CAP , CHIP	100PF 50V J	1
C1160	CCUS1H101JA	CAP , CHIP	100PF 50V J	1
C1161	CCUS1H101JA	CAP , CHIP	100PF 50V J	1
C1162	CCUS1H101JA	CAP , CHIP	100PF 50V J	1
C1163	CCUS1H101JA	CAP , CHIP	100PF 50V J	1
C1164	CCUS1H101JA	CAP , CHIP	100PF 50V J	1
C1165	CCUS1H101JA	CAP , CHIP	100PF 50V J	1
C1166	CCUS1H101JA	CAP , CHIP	100PF 50V J	1
C1167	CCUS1H101JA	CAP , CHIP	100PF 50V J	1
C1168	CCUS1H101JA	CAP , CHIP	100PF 50V J	1
C1169	CCUS1H101JA	CAP , CHIP	100PF 50V J	1
C1173	CCUS1H101JA	CAP , CHIP	100PF 50V J	1
C1174	CCUS1H101JA	CAP , CHIP	100PF 50V J	1
C1175	CCUS1H101JA	CAP , CHIP	100PF 50V J	1
C1176	CCUS1H101JA	CAP , CHIP	100PF 50V J	1
C1177	CCUS1H101JA	CAP , CHIP	100PF 50V J	1
C1178	CCUS1H101JA	CAP , CHIP	100PF 50V J	1
C1179	CCUS1H101JA	CAP , CHIP	100PF 50V J	1
C1180	CCUS1H101JA	CAP , CHIP	100PF 50V J	1
C1181	CCUS1H101JA	CAP , CHIP	100PF 50V J	1
C1182	CCUS1H101JA	CAP , CHIP	100PF 50V J	1
C1183	CCUS1H101JA	CAP , CHIP	100PF 50V J	1
C1184	CCUS1H101JA	CAP , CHIP	100PF 50V J	1
C1187	CCUS1H101JA	CAP , CHIP	100PF 50V J	1
C1188	CCUS1H101JA	CAP , CHIP	100PF 50V J	1
C1189	CCUS1H101JA	CAP , CHIP	100PF 50V J	1

Ref. Designator	Part Number	Description		Qty
PROCESSOR PCB ASS'Y		COP12042B		
C1190	CCUS1H101JA	CAP , CHIP	100PF 50V J	1
C1191	CCUS1H151JA	CAP , CHIP	150PF 50V J	1
C1192	CCUS1H151JA	CAP , CHIP	150PF 50V J	1
C1193	CCUS1H101JA	CAP , CHIP	100PF 50V J	1
C1194	CCUS1H101JA	CAP , CHIP	100PF 50V J	1
C1195	CCUS1H101JA	CAP , CHIP	100PF 50V J	1
C1196	CCUS1H101JA	CAP , CHIP	100PF 50V J	1
C1197	CCUS1H101JA	CAP , CHIP	100PF 50V J	1
C1198	CCUS1H101JA	CAP , CHIP	100PF 50V J	1
C1199	CCUS1H121JA	CAP , CHIP	120PF 50V J	1
C1200	CCUS1H121JA	CAP , CHIP	120PF 50V J	1
C1205	CCUS1H151JA	CAP , CHIP	150PF 50V J	1
C1206	CCUS1H151JA	CAP , CHIP	150PF 50V J	1
C1207	CCUS1H104KC	CAP , CHIP	0.1UF 50V K	1
C1208	CCUS1H104KC	CAP , CHIP	0.1UF 50V K	1
C1209	CCUS1H104KC	CAP , CHIP	0.1UF 50V K	1
C1210	CCUS1H222KC	CAP , CHIP	2200PF 50V K	1
C1211	CCUS1H104KC	CAP , CHIP	0.1UF 50V K	1
C1212	CCUS1H104KC	CAP , CHIP	0.1UF 50V K	1
C1213	CCUS1H104KC	CAP , CHIP	0.1UF 50V K	1
C1214	CCUS1H104KC	CAP , CHIP	0.1UF 50V K	1
C1215	CCUS1H104KC	CAP , CHIP	0.1UF 50V K	1
C1216	CCUS1H101JA	CAP , CHIP	100PF 50V J	1
C1217	CCUS1H330JA	CAP , CHIP	33PF 50V J	1
C1218	CCUS1H330JA	CAP , CHIP	33PF 50V J	1
C1219	CCUS1H101JA	CAP , CHIP	100PF 50V J	1
C1220	CCUS1H101JA	CAP , CHIP	100PF 50V J	1
C1221	CCUS1H151JA	CAP , CHIP	150PF 50V J	1
C1222	CCUS1H151JA	CAP , CHIP	150PF 50V J	1
C1004	CCUS1H104KC	CAP , CHIP	0.1UF 50V K	1
C1005	CCUS1H104KC	CAP , CHIP	0.1UF 50V K	1
C1026	CCUS1H101JA	CAP , CHIP	100PF 50V J	1
C1036	CCUS1H101JA	CAP , CHIP	100PF 50V J	1
C1039	CCUS1H151JA	CAP , CHIP	150PF 50V J	1
C1040	CCUS1H151JA	CAP , CHIP	150PF 50V J	1
C1047	CCUS1H101JA	CAP , CHIP	100PF 50V J	1
C1048	CCUS1H101JA	CAP , CHIP	100PF 50V J	1
C1059	CCUS1H101JA	CAP , CHIP	100PF 50V J	1
C1063	CCUS1H101JA	CAP , CHIP	100PF 50V J	1
C1067	CCUS1H222KC	CAP , CHIP	2200PF 50V K	1
C1074	CCUS1H101JA	CAP , CHIP	100PF 50V J	1
C1081	CCUS1H101JA	CAP , CHIP	100PF 50V J	1
C1084	CCUS1H101JA	CAP , CHIP	100PF 50V J	1
C1085	CCUS1H101JA	CAP , CHIP	100PF 50V J	1
C1089	CCUS1H101JA	CAP , CHIP	100PF 50V J	1
C1122	CCUS1H151JA	CAP , CHIP	150PF 50V J	1
C1123	CCUS1H101JA	CAP , CHIP	100PF 50V J	1
C1124	CCUS1H151JA	CAP , CHIP	150PF 50V J	1
C1125	CCUS1H151JA	CAP , CHIP	150PF 50V J	1
C1126	CCUS1H151JA	CAP , CHIP	150PF 50V J	1
C1127	CCUS1H151JA	CAP , CHIP	150PF 50V J	1
C1128	CCUS1H101JA	CAP , CHIP	100PF 50V J	1
C1129	CCUS1H560JA	CAP , CHIP	56PF 50V J	1
C1130	CCUS1H560JA	CAP , CHIP	56PF 50V J	1
C1131	CCUS1H330JA	CAP , CHIP	33PF 50V J	1
C1132	CCUS1H560JA	CAP , CHIP	56PF 50V J	1
C1133	CCUS1H560JA	CAP , CHIP	56PF 50V J	1
C1134	CCUS1H560JA	CAP , CHIP	56PF 50V J	1
C1135	CCUS1H330JA	CAP , CHIP	33PF 50V J	1
C1136	CCUS1H271JA	CAP , CHIP	270PF 50V J	1
C1145	CCUS1H271JA	CAP , CHIP	270PF 50V J	1
C1148	CCUS1H104KC	CAP , CHIP	0.1UF 50V K	1
C1149	CCUS1H104KC	CAP , CHIP	0.1UF 50V K	1
C1000	CCEA1CH100T	CAP , ELECT	10UF 16V	1
C1001	CCEA1CH100T	CAP , ELECT	10UF 16V	1
C1002	CCEA1CH100T	CAP , ELECT	10UF 16V	1
C1003	CCEA1CH100T	CAP , ELECT	10UF 16V	1
C1006	CCEA1CH100T	CAP , ELECT	10UF 16V	1
C1007	CCEA1CH100T	CAP , ELECT	10UF 16V	1
C1008	CCEA1CH100T	CAP , ELECT	10UF 16V	1
C1009	CCEA1CH100T	CAP , ELECT	10UF 16V	1

Ref. Designator	Part Number	Description		Qty
PROCESSOR PCB ASS'Y		COP12042B		
C1012	CCEA1CH100T	CAP , ELECT	10UF 16V	1
C1013	CCEA1CH100T	CAP , ELECT	10UF 16V	1
C1014	CCEA1CH101T	CAP , ELECT	100UF 16V	1
C1015	CCEA1CH101T	CAP , ELECT	100UF 16V	1
C1016	CCEA1HH1R0T	CAP , ELECT	1UF 50V	1
C1017	CCEA1HH1R0T	CAP , ELECT	1UF 50V	1
C1018	CCEA1HH1R0T	CAP , ELECT	1UF 50V	1
C1019	CCEA1CH100T	CAP , ELECT	10UF 16V	1
C1020	CCEA1CH100T	CAP , ELECT	10UF 16V	1
C1021	CCEA1CH100T	CAP , ELECT	10UF 16V	1
C1022	CCEA1CH100T	CAP , ELECT	10UF 16V	1
C1037	CCEA1CH100T	CAP , ELECT	10UF 16V	1
C1038	CCEA1CH100T	CAP , ELECT	10UF 16V	1
C1043	CCEA1CH100T	CAP , ELECT	10UF 16V	1
C1044	CCEA1CH100T	CAP , ELECT	10UF 16V	1
C1045	CCEA1CH100T	CAP , ELECT	10UF 16V	1
C1046	CCEA1CH100T	CAP , ELECT	10UF 16V	1
C1049	CCEA1CH100T	CAP , ELECT	10UF 16V	1
C1050	CCEA1CH100T	CAP , ELECT	10UF 16V	1
C1051	CCEA1CH100T	CAP , ELECT	10UF 16V	1
C1052	CCEA1CH100T	CAP , ELECT	10UF 16V	1
C1053	CCEA1CH100T	CAP , ELECT	10UF 16V	1
C1054	CCEA1CH100T	CAP , ELECT	10UF 16V	1
C1060	CCEA1CH100T	CAP , ELECT	10UF 16V	1
C1061	CCEA1CH100T	CAP , ELECT	10UF 16V	1
C1062	CCEA1CH100T	CAP , ELECT	10UF 16V	1
C1071	CCEA1CH100T	CAP , ELECT	10UF 16V	1
C1075	CCEA1CH100T	CAP , ELECT	10UF 16V	1
C1076	CCEA1CH100T	CAP , ELECT	10UF 16V	1
C1077	CCEA1CH100T	CAP , ELECT	10UF 16V	1
C1078	CCEA1CH100T	CAP , ELECT	10UF 16V	1
C1086	CCEA1CH100T	CAP , ELECT	10UF 16V	1
C1087	CCEA1CH100T	CAP , ELECT	10UF 16V	1
C1088	CCEA1HH100T	CAP , ELECT	10UF 50V	1
C1090	CCEA1CH100T	CAP , ELECT	10UF 16V	1
C1091	CCEA1CH100T	CAP , ELECT	10UF 16V	1
C1092	CCEA1CH100T	CAP , ELECT	10UF 16V	1
C1093	CCEA1CH100T	CAP , ELECT	10UF 16V	1
C1098	CCEA1CH100T	CAP , ELECT	10UF 16V	1
C1099	CCEA1CH100T	CAP , ELECT	10UF 16V	1
C1102	CCEA1CH101T	CAP , ELECT	100UF 16V	1
C1103	CCEA1CH101T	CAP , ELECT	100UF 16V	1
C1112	CCEA1CH100T	CAP , ELECT	10UF 16V	1
C1113	CCEA1CH100T	CAP , ELECT	10UF 16V	1
C1114	CCEA1CH100T	CAP , ELECT	10UF 16V	1
C1115	CCEA1CH100T	CAP , ELECT	10UF 16V	1
C1116	CCEA1CH100T	CAP , ELECT	10UF 16V	1
C1117	CCEA1CH100T	CAP , ELECT	10UF 16V	1
C1118	CCEA1CH100T	CAP , ELECT	10UF 16V	1
C1119	CCEA1CH100T	CAP , ELECT	10UF 16V	1
C1120	CCEA1CH100T	CAP , ELECT	10UF 16V	1
C1121	CCEA1CH100T	CAP , ELECT	10UF 16V	1
C1137	CCEA1CH100T	CAP , ELECT	10UF 16V	1
C1138	CCEA1CH100T	CAP , ELECT	10UF 16V	1
C1139	CCEA1CH100T	CAP , ELECT	10UF 16V	1
C1140	CCEA1CH100T	CAP , ELECT	10UF 16V	1
C1141	CCEA1CH100T	CAP , ELECT	10UF 16V	1
C1142	CCEA1CH100T	CAP , ELECT	10UF 16V	1
C1143	CCEA1CH100T	CAP , ELECT	10UF 16V	1
C1144	CCEA1CH100T	CAP , ELECT	10UF 16V	1
C1146	CCEA1EH331T	CAP , ELECT	330UF 25V	1
C1147	CCEA1EH331T	CAP , ELECT	330UF 25V	1
C1223	CCEA1AH471T	CAP , ELECT	470UF 10V	1
<i>Semiconductors</i>				
D1003	HVD1SS355T	DIODE , CHIP	1SS355TE-17	1
IC1015	HVINJM2068MDTE1	I.C , DUAL OP AMP	NJM2068MD-TE1	1
IC1016	HVINJM2068MDTE1	I.C , DUAL OP AMP	NJM2068MD-TE1	1
IC1017	CVITC9273CFG	I.C , ANALOG SW(3.0V, 10X2CH, SOP-28)	TC9273CFG , TOSHIBA	1
IC1018	HVINJM2068MDTE1	I.C , DUAL OP AMP	NJM2068MD-TE1	1

Ref. Designator	Part Number	Description		Qty
PROCESSOR PCB ASS'Y		COP12042B		
IC1019	HVINJM2068MDTE1	I.C , DUAL OP AMP	NJM2068MD-TE1	1
IC1020	HVINJM2068MDTE1	I.C , DUAL OP AMP	NJM2068MD-TE1	1
IC1022	HVINJM2068MDTE1	I.C , DUAL OP AMP	NJM2068MD-TE1	1
IC1023	HVINJM2068MDTE1	I.C , DUAL OP AMP	NJM2068MD-TE1	1
IC1024	HVINJM2068MDTE1	I.C , DUAL OP AMP	NJM2068MD-TE1	1
IC1025	HVINJM2068MDTE1	I.C , DUAL OP AMP	NJM2068MD-TE1	1
Q1028	HVTKRA107S	TRANSISTOR, CHIP NPN	KRA107S-RTK/P	1
Q1029	HVTKRA107S	TRANSISTOR, CHIP NPN	KRA107S-RTK/P	1
Q1031	HVTKRC107S	TRANSISTOR, CHIP NPN	KRC107S-RTK/P	1
Q1036	HVTKTD1304T	TRANSISTOR , CHIP (MUTE) NPN	KTD1304	1
Q1037	HVTKTD1304T	TRANSISTOR , CHIP (MUTE) NPN	KTD1304	1
Q1038	HVTKRA107S	TRANSISTOR, CHIP NPN	KRA107S-RTK/P	1
Q1039	HVTKRA107S	TRANSISTOR, CHIP NPN	KRA107S-RTK/P	1
Q1046	HVTKRA107S	TRANSISTOR, CHIP NPN	KRA107S-RTK/P	1
Q1049	HVTKRA107S	TRANSISTOR, CHIP NPN	KRA107S-RTK/P	1
Q1050	HVTKRA107S	TRANSISTOR, CHIP NPN	KRA107S-RTK/P	1
Q1051	HVTKRA107S	TRANSISTOR, CHIP NPN	KRA107S-RTK/P	1
Q1052	HVTKRA107S	TRANSISTOR, CHIP NPN	KRA107S-RTK/P	1
Q1053	HVTKTD1304T	TRANSISTOR , CHIP (MUTE) NPN	KTD1304	1
Q1054	HVTKTD1304T	TRANSISTOR , CHIP (MUTE) NPN	KTD1304	1
D1004	HVDUDZ5.1BSR	DIODE , ZENER (CHIP,5.1V)	UDZ5 5.1B 5.1V 200mW UMD2	1
IC1000	CVITC9273CFG	I.C , ANALOG SW(3.0V, 10X2CH, SOP-28)	TC9273CFG-004 SOP28	1
IC1001	HVITC9162CFG	I.C , FUNCTION SW	TC9162CFG SOP28	1
IC1002	HVINJM2068MDTE1	I.C , DUAL OP AMP	NJM2068M-TE1 SOP8	1
IC1003	HVITC9163CFG	I.C , FUNCTION SW	TC9163CFG SOP28	1
IC1004	HVINJM2068MDTE1	I.C , DUAL OP AMP	NJM2068M-TE1 SOP8	1
IC1005	HVINJM2068MDTE1	I.C , DUAL OP AMP	NJM2068M-TE1 SOP8	1
IC1006	HVITC9482BFG	I.C , 6CH VOLUME	TC9482BFG SOP28	1
IC1007	HVITC9482BFG	I.C , 6CH VOLUME	TC9482BFG SOP28	1
IC1008	HVINJM2068MDTE1	I.C , DUAL OP AMP	NJM2068M-TE1 SOP8	1
IC1009	HVINJM2068MDTE1	I.C , DUAL OP AMP	NJM2068M-TE1 SOP8	1
IC1010	HVINJM2068MDTE1	I.C , DUAL OP AMP	NJM2068M-TE1 SOP8	1
IC1011	HVINJM2068MDTE1	I.C , DUAL OP AMP	NJM2068M-TE1 SOP8	1
IC1012	HVINJM2068MDTE1	I.C , DUAL OP AMP	NJM2068M-TE1 SOP8	1
IC1013	HVINJM2068MDTE1	I.C , DUAL OP AMP	NJM2068M-TE1 SOP8	1
Q1000	HVTKTD1304T	TRANSISTOR , CHIP (MUTE) NPN	KTD1304	1
Q1001	HVTKTD1304T	TRANSISTOR , CHIP (MUTE) NPN	KTD1304	1
Q1002	HVTKTD1304T	TRANSISTOR , CHIP (MUTE) NPN	KTD1304	1
Q1003	HVTKTD1304T	TRANSISTOR , CHIP (MUTE) NPN	KTD1304	1
Q1004	HVTKTD1304T	TRANSISTOR , CHIP (MUTE) NPN	KTD1304	1
Q1005	HVTKTD1304T	TRANSISTOR , CHIP (MUTE) NPN	KTD1304	1
Q1008	HVTKTD1304T	TRANSISTOR , CHIP (MUTE) NPN	KTD1304	1
Q1009	HVTKTD1304T	TRANSISTOR , CHIP (MUTE) NPN	KTD1304	1
Q1010	HVTKTD1304T	TRANSISTOR , CHIP (MUTE) NPN	KTD1304	1
Q1011	HVTKTD1304T	TRANSISTOR , CHIP (MUTE) NPN	KTD1304	1
Q1012	HVTKTD1304T	TRANSISTOR , CHIP (MUTE) NPN	KTD1304	1
Q1018	HVTKTD1304T	TRANSISTOR , CHIP (MUTE) NPN	KTD1304	1
Q1019	HVTKTD1304T	TRANSISTOR , CHIP (MUTE) NPN	KTD1304	1
Q1020	HVTKTD1304T	TRANSISTOR , CHIP (MUTE) NPN	KTD1304	1
Q1021	HVTKTD1304T	TRANSISTOR , CHIP (MUTE) NPN	KTD1304	1
Q1022	HVTKTD1304T	TRANSISTOR , CHIP (MUTE) NPN	KTD1304	1
Q1023	HVTKTD1304T	TRANSISTOR , CHIP (MUTE) NPN	KTD1304	1
Q1024	HVTKTD1304T	TRANSISTOR , CHIP (MUTE) NPN	KTD1304	1
Q1025	HVTKTD1304T	TRANSISTOR , CHIP (MUTE) NPN	KTD1304	1
Q1026	HVTKTD1304T	TRANSISTOR , CHIP (MUTE) NPN	KTD1304	1
Q1027	HVTKTD1304T	TRANSISTOR , CHIP (MUTE) NPN	KTD1304	1
IC1014	HVINJM4556AD	I.C , DUAL OP AMP	NJM4556AD	1
<i>Resistors</i>				
R1101	CRJ10DJ823T	RES , CHIP	82K ohm 1/16W 5% 0603	1
R1102	CRJ10DJ823T	RES , CHIP	82K ohm 1/16W 5% 0603	1
R1103	CRJ10DJ823T	RES , CHIP	82K ohm 1/16W 5% 0603	1
R1104	CRJ10DJ823T	RES , CHIP	82K ohm 1/16W 5% 0603	1
R1105	CRJ10DJ823T	RES , CHIP	82K ohm 1/16W 5% 0603	1
R1106	CRJ10DJ823T	RES , CHIP	82K ohm 1/16W 5% 0603	1
R1107	CRJ10DJ823T	RES , CHIP	82K ohm 1/16W 5% 0603	1
R1108	CRJ10DJ823T	RES , CHIP	82K ohm 1/16W 5% 0603	1
R1109	CRJ10DJ823T	RES , CHIP	82K ohm 1/16W 5% 0603	1
R1110	CRJ10DJ823T	RES , CHIP	82K ohm 1/16W 5% 0603	1
R1111	CRJ10DJ471T	RES , CHIP	470 ohm 1/16W 5% 0603	1

Ref. Designator	Part Number	Description	Qty
PROCESSOR PCB ASS'Y		COP12042B	
R1112	CRJ10DJ471T	RES , CHIP	470 ohm 1/16W 5% 0603
R1113	CRJ10DJ471T	RES , CHIP	470 ohm 1/16W 5% 0603
R1116	CRJ10DJ102T	RES , CHIP	1K ohm 1/16W 5% 0603
R1117	CRJ10DJ102T	RES , CHIP	1K ohm 1/16W 5% 0603
R1118	CRJ10DJ102T	RES , CHIP	1K ohm 1/16W 5% 0603
R1119	CRJ10DJ102T	RES , CHIP	1K ohm 1/16W 5% 0603
R1120	CRJ10DJ471T	RES , CHIP	470 ohm 1/16W 5% 0603
R1121	CRJ10DJ471T	RES , CHIP	470 ohm 1/16W 5% 0603
R1122	CRJ10DJ102T	RES , CHIP	1K ohm 1/16W 5% 0603
R1123	CRJ10DJ102T	RES , CHIP	1K ohm 1/16W 5% 0603
R1124	CRJ10DJ471T	RES , CHIP	470 ohm 1/16W 5% 0603
R1125	CRJ10DJ471T	RES , CHIP	470 ohm 1/16W 5% 0603
R1126	CRJ10DJ102T	RES , CHIP	1K ohm 1/16W 5% 0603
R1127	CRJ10DJ102T	RES , CHIP	1K ohm 1/16W 5% 0603
R1128	CRJ10DJ102T	RES , CHIP	1K ohm 1/16W 5% 0603
R1129	CRJ10DJ102T	RES , CHIP	1K ohm 1/16W 5% 0603
R1132	CRJ10DJ104T	RES , CHIP	100K ohm 1/16W 5% 0603
R1133	CRJ10DJ104T	RES , CHIP	100K ohm 1/16W 5% 0603
R1134	CRJ10DJ104T	RES , CHIP	100K ohm 1/16W 5% 0603
R1135	CRJ10DJ104T	RES , CHIP	100K ohm 1/16W 5% 0603
R1136	CRJ10DJ102T	RES , CHIP	1K ohm 1/16W 5% 0603
R1137	CRJ10DJ102T	RES , CHIP	1K ohm 1/16W 5% 0603
R1138	CRJ10DJ104T	RES , CHIP	100K ohm 1/16W 5% 0603
R1139	CRJ10DJ104T	RES , CHIP	100K ohm 1/16W 5% 0603
R1140	CRJ10DJ102T	RES , CHIP	1K ohm 1/16W 5% 0603
R1141	CRJ10DJ102T	RES , CHIP	1K ohm 1/16W 5% 0603
R1142	CRJ10DJ102T	RES , CHIP	1K ohm 1/16W 5% 0603
R1143	CRJ10DJ102T	RES , CHIP	1K ohm 1/16W 5% 0603
R1144	CRJ10DJ104T	RES , CHIP	100K ohm 1/16W 5% 0603
R1145	CRJ10DJ104T	RES , CHIP	100K ohm 1/16W 5% 0603
R1146	CRJ10DJ104T	RES , CHIP	100K ohm 1/16W 5% 0603
R1147	CRJ10DJ104T	RES , CHIP	100K ohm 1/16W 5% 0603
R1148	CRJ10DJ104T	RES , CHIP	100K ohm 1/16W 5% 0603
R1149	CRJ10DJ104T	RES , CHIP	100K ohm 1/16W 5% 0603
R1150	CRJ10DJ104T	RES , CHIP	100K ohm 1/16W 5% 0603
R1151	CRJ10DJ104T	RES , CHIP	100K ohm 1/16W 5% 0603
R1152	CRJ10DJ104T	RES , CHIP	100K ohm 1/16W 5% 0603
R1153	CRJ10DJ104T	RES , CHIP	100K ohm 1/16W 5% 0603
R1154	CRJ10DJ104T	RES , CHIP	100K ohm 1/16W 5% 0603
R1155	CRJ10DJ512T	RES , CHIP	5K1 ohm 1/16W 5% 0603
R1156	CRJ10DJ104T	RES , CHIP	100K ohm 1/16W 5% 0603
R1157	CRJ10DJ512T	RES , CHIP	5K1 ohm 1/16W 5% 0603
R1158	CRJ10DJ104T	RES , CHIP	100K ohm 1/16W 5% 0603
R1159	CRJ10DJ104T	RES , CHIP	100K ohm 1/16W 5% 0603
R1160	CRJ10DJ102T	RES , CHIP	1K ohm 1/16W 5% 0603
R1161	CRJ10DJ102T	RES , CHIP	1K ohm 1/16W 5% 0603
R1164	CRJ10DJ102T	RES , CHIP	1K ohm 1/16W 5% 0603
R1165	CRJ10DJ104T	RES , CHIP	100K ohm 1/16W 5% 0603
R1166	CRJ10DJ104T	RES , CHIP	100K ohm 1/16W 5% 0603
R1167	CRJ10DJ104T	RES , CHIP	100K ohm 1/16W 5% 0603
R1168	CRJ10DJ104T	RES , CHIP	100K ohm 1/16W 5% 0603
R1169	CRJ10DJ104T	RES , CHIP	100K ohm 1/16W 5% 0603
R1170	CRJ10DJ104T	RES , CHIP	100K ohm 1/16W 5% 0603
R1171	CRJ10DJ104T	RES , CHIP	100K ohm 1/16W 5% 0603
R1172	CRJ10DJ104T	RES , CHIP	100K ohm 1/16W 5% 0603
R1173	CRJ10DJ102T	RES , CHIP	1K ohm 1/16W 5% 0603
R1174	CRJ10DJ473T	RES , CHIP	47K ohm 1/16W 5% 0603
R1175	CRJ10DJ473T	RES , CHIP	47K ohm 1/16W 5% 0603
R1176	CRJ10DJ471T	RES , CHIP	470 ohm 1/16W 5% 0603
R1177	CRJ10DJ471T	RES , CHIP	470 ohm 1/16W 5% 0603
R1178	CRJ10DJ104T	RES , CHIP	100K ohm 1/16W 5% 0603
R1179	CRJ10DJ104T	RES , CHIP	100K ohm 1/16W 5% 0603
R1180	CRJ10DJ104T	RES , CHIP	100K ohm 1/16W 5% 0603
R1181	CRJ10DJ104T	RES , CHIP	100K ohm 1/16W 5% 0603
R1182	CRJ10DJ104T	RES , CHIP	100K ohm 1/16W 5% 0603
R1185	CRJ10DJ104T	RES , CHIP	100K ohm 1/16W 5% 0603
R1186	CRJ10DJ104T	RES , CHIP	100K ohm 1/16W 5% 0603
R1187	CRJ10DJ104T	RES , CHIP	100K ohm 1/16W 5% 0603
R1188	CRJ10DJ103T	RES , CHIP	10K ohm 1/16W 5% 0603
R1189	CRJ10DJ100T	RES , CHIP	10 ohm 1/16W 5% 0603
R1190	CRJ10DJ100T	RES , CHIP	10 ohm 1/16W 5% 0603

Ref. Designator	Part Number	Description	Qty
PROCESSOR PCB ASS'Y		COP12042B	
R1191	CRJ10DJ103T	RES , CHIP	10K ohm 1/16W 5% 0603
R1192	CRJ10DJ103T	RES , CHIP	10K ohm 1/16W 5% 0603
R1193	CRJ10DJ471T	RES , CHIP	470 ohm 1/16W 5% 0603
R1194	CRJ10DJ471T	RES , CHIP	470 ohm 1/16W 5% 0603
R1195	CRJ10DJ471T	RES , CHIP	470 ohm 1/16W 5% 0603
R1196	CRJ10DJ0R0T	RES , CHIP	0 ohm 1/16W 0% 0603
R1197	CRJ10DJ0R0T	RES , CHIP	0 ohm 1/16W 0% 0603
R1198	CRJ10DJ471T	RES , CHIP	470 ohm 1/16W 5% 0603
R1201	CRJ10DJ0R0T	RES , CHIP	0 ohm 1/16W 0% 0603
R1202	CRJ10DJ102T	RES , CHIP	1K ohm 1/16W 5% 0603
R1203	CRJ10DJ0R0T	RES , CHIP	0 ohm 1/16W 0% 0603
R1204	CRJ10DJ0R0T	RES , CHIP	0 ohm 1/16W 0% 0603
R1205	CRJ10DJ471T	RES , CHIP	470 ohm 1/16W 5% 0603
R1206	CRJ10DJ471T	RES , CHIP	470 ohm 1/16W 5% 0603
R1207	CRJ10DJ0R0T	RES , CHIP	0 ohm 1/16W 0% 0603
R1208	CRJ10DJ0R0T	RES , CHIP	0 ohm 1/16W 0% 0603
R1209	CRJ10DJ0R0T	RES , CHIP	0 ohm 1/16W 0% 0603
R1212	CRJ10DJ0R0T	RES , CHIP	0 ohm 1/16W 0% 0603
R1213	CRJ10DJ104T	RES , CHIP	100K ohm 1/16W 5% 0603
R1214	CRJ10DJ820T	RES , CHIP	82 ohm 1/16W 5% 0603
R1215	CRJ10DJ0R0T	RES , CHIP	0 ohm 1/16W 0% 0603
R1216	CRJ10DJ0R0T	RES , CHIP	0 ohm 1/16W 0% 0603
R1217	CRJ10DJ820T	RES , CHIP	82 ohm 1/16W 5% 0603
R1218	CRJ10DJ104T	RES , CHIP	100K ohm 1/16W 5% 0603
R1219	CRJ10DJ104T	RES , CHIP	100K ohm 1/16W 5% 0603
R1220	CRJ10DJ104T	RES , CHIP	100K ohm 1/16W 5% 0603
R1221	CRJ10DJ0R0T	RES , CHIP	0 ohm 1/16W 0% 0603
R1222	CRJ10DJ0R0T	RES , CHIP	0 ohm 1/16W 0% 0603
R1223	CRJ10DJ0R0T	RES , CHIP	0 ohm 1/16W 0% 0603
R1224	CRJ10DJ432T	RES , CHIP	4K3 ohm 1/16W 5% 0603
R1225	CRJ10DJ104T	RES , CHIP	100K ohm 1/16W 5% 0603
R1226	CRJ10DJ104T	RES , CHIP	100K ohm 1/16W 5% 0603
R1227	CRJ10DJ432T	RES , CHIP	4K3 ohm 1/16W 5% 0603
R1228	CRJ10DJ272T	RES , CHIP	2K7 ohm 1/16W 5% 0603
R1229	CRJ10DJ272T	RES , CHIP	2K7 ohm 1/16W 5% 0603
R1230	CRJ10DJ471T	RES , CHIP	470 ohm 1/16W 5% 0603
R1231	CRJ10DJ471T	RES , CHIP	470 ohm 1/16W 5% 0603
R1232	CRJ10DJ0R0T	RES , CHIP	0 ohm 1/16W 0% 0603
R1233	CRJ10DJ0R0T	RES , CHIP	0 ohm 1/16W 0% 0603
R1234	CRJ10DJ104T	RES , CHIP	100K ohm 1/16W 5% 0603
R1235	CRJ10DJ104T	RES , CHIP	100K ohm 1/16W 5% 0603
R1236	CRJ10DJ104T	RES , CHIP	100K ohm 1/16W 5% 0603
R1237	CRJ10DJ471T	RES , CHIP	470 ohm 1/16W 5% 0603
R1238	CRJ10DJ471T	RES , CHIP	470 ohm 1/16W 5% 0603
R1239	CRJ10DJ104T	RES , CHIP	100K ohm 1/16W 5% 0603
R1240	CRJ10DJ103T	RES , CHIP	10K ohm 1/16W 5% 0603
R1241	CRJ10DJ103T	RES , CHIP	10K ohm 1/16W 5% 0603
R1242	CRJ10DJ0R0T	RES , CHIP	0 ohm 1/16W 0% 0603
R1243	CRJ10DJ122T	RES , CHIP	1K2 ohm 1/16W 5% 0603
R1244	CRJ10DJ122T	RES , CHIP	1K2 ohm 1/16W 5% 0603
R1245	CRJ10DJ0R0T	RES , CHIP	0 ohm 1/16W 0% 0603
R1246	CRJ10DJ430T	RES , CHIP(43ohm,1/10W ,5%,1608)	43ohm,1/10W ,5%,1608
R1247	CRJ10DJ430T	RES , CHIP(43ohm,1/10W ,5%,1608)	43ohm,1/10W ,5%,1608
R1248	CRJ10DJ102T	RES , CHIP	1K ohm 1/16W 5% 0603
R1249	CRJ10DJ104T	RES , CHIP	100K ohm 1/16W 5% 0603
R1250	CRJ10DJ104T	RES , CHIP	100K ohm 1/16W 5% 0603
R1251	CRJ10DJ0R0T	RES , CHIP	0 ohm 1/16W 0% 0603
R1252	CRJ10DJ0R0T	RES , CHIP	0 ohm 1/16W 0% 0603
R1253	CRJ10DJ0R0T	RES , CHIP	0 ohm 1/16W 0% 0603
R1254	CRJ10DJ0R0T	RES , CHIP	0 ohm 1/16W 0% 0603
R1255	CRJ10DJ471T	RES , CHIP	470 ohm 1/16W 5% 0603
R1256	CRJ10DJ0R0T	RES , CHIP	0 ohm 1/16W 0% 0603
R1257	CRJ10DJ0R0T	RES , CHIP	0 ohm 1/16W 0% 0603
R1258	CRJ10DJ0R0T	RES , CHIP	0 ohm 1/16W 0% 0603
R1259	CRJ10DJ0R0T	RES , CHIP	0 ohm 1/16W 0% 0603
R1260	CRJ10DJ473T	RES , CHIP	47K ohm 1/16W 5% 0603
R1261	CRJ10DJ471T	RES , CHIP	470 ohm 1/16W 5% 0603
R1262	CRJ10DJ471T	RES , CHIP	470 ohm 1/16W 5% 0603
R1263	CRJ10DJ473T	RES , CHIP	47K ohm 1/16W 5% 0603
R1264	CRJ10DJ471T	RES , CHIP	470 ohm 1/16W 5% 0603
R1265	CRJ10DJ473T	RES , CHIP	47K ohm 1/16W 5% 0603

Ref. Designator	Part Number	Description	Qty
PROCESSOR PCB ASS'Y		COP12042B	
R1266	CRJ10DJ471T	RES , CHIP	470 ohm 1/16W 5% 0603
R1267	CRJ10DJ473T	RES , CHIP	47K ohm 1/16W 5% 0603
R1268	CRJ10DJ0R0T	RES , CHIP	0 ohm 1/16W 0% 0603
R1269	CRJ10DJ0R0T	RES , CHIP	0 ohm 1/16W 0% 0603
R1270	CRJ10DJ104T	RES , CHIP	100K ohm 1/16W 5% 0603
R1271	CRJ10DJ471T	RES , CHIP	470 ohm 1/16W 5% 0603
R1272	CRJ10DJ473T	RES , CHIP	47K ohm 1/16W 5% 0603
R1273	CRJ10DJ103T	RES , CHIP	10K ohm 1/16W 5% 0603
R1274	CRJ10DJ202T	RES , CHIP	2K ohm 1/16W 5% 0603
R1275	CRJ10DJ471T	RES , CHIP	470 ohm 1/16W 5% 0603
R1276	CRJ10DJ473T	RES , CHIP	47K ohm 1/16W 5% 0603
R1277	CRJ10DJ103T	RES , CHIP	10K ohm 1/16W 5% 0603
R1278	CRJ10DJ473T	RES , CHIP	47K ohm 1/16W 5% 0603
R1279	CRJ10DJ102T	RES , CHIP	1K ohm 1/16W 5% 0603
R1280	CRJ10DJ473T	RES , CHIP	47K ohm 1/16W 5% 0603
R1281	CRJ10DJ123T	RES , CHIP	12K ohm 1/16W 5% 0603
R1283	CRJ10DJ104T	RES , CHIP	100K ohm 1/16W 5% 0603
R1284	CRJ10DJ104T	RES , CHIP	100K ohm 1/16W 5% 0603
R1285	CRJ10DJ123T	RES , CHIP	12K ohm 1/16W 5% 0603
R1286	CRJ10DJ911T	RES , CHIP	910 ohm 1/16W 5% 0603
R1288	CRJ10DJ104T	RES , CHIP	100K ohm 1/16W 5% 0603
R1289	CRJ10DJ104T	RES , CHIP	100K ohm 1/16W 5% 0603
R1290	CRJ10DJ911T	RES , CHIP	910 ohm 1/16W 5% 0603
R1292	CRJ10DJ0R0T	RES , CHIP	0 ohm 1/16W 0% 0603
R1293	CRJ10DJ0R0T	RES , CHIP	0 ohm 1/16W 0% 0603
R1294	CRJ10DJ0R0T	RES , CHIP	0 ohm 1/16W 0% 0603
R1295	CRJ10DJ0R0T	RES , CHIP	0 ohm 1/16W 0% 0603
R1298	CRJ10DJ0R0T	RES , CHIP	0 ohm 1/16W 0% 0603
R1299	CRJ10DJ0R0T	RES , CHIP	0 ohm 1/16W 0% 0603
R1300	CRJ10DJ102T	RES , CHIP	1K ohm 1/16W 5% 0603
R1301	CRJ10DJ102T	RES , CHIP	1K ohm 1/16W 5% 0603
R1303	CRJ10DJ104T	RES , CHIP	100K ohm 1/16W 5% 0603
R1304	CRJ10DJ104T	RES , CHIP	100K ohm 1/16W 5% 0603
R1309	CRJ10DJ100T	RES , CHIP	10 ohm 1/16W 5% 0603
R1310	CRJ10DJ100T	RES , CHIP	10 ohm 1/16W 5% 0603
R1312	CRJ10DJ0R0T	RES , CHIP	0 ohm 1/16W 0% 0603
R1313	CRJ10DJ0R0T	RES , CHIP	0 ohm 1/16W 0% 0603
R1314	CRJ10DJ0R0T	RES , CHIP	0 ohm 1/16W 0% 0603
R1315	CRJ10DJ0R0T	RES , CHIP	0 ohm 1/16W 0% 0603
R1316	CRJ10DJ0R0T	RES , CHIP	0 ohm 1/16W 0% 0603
R1317	CRJ10DJ0R0T	RES , CHIP	0 ohm 1/16W 0% 0603
R1318	CRJ10DJ0R0T	RES , CHIP	0 ohm 1/16W 0% 0603
R1319	CRJ10DJ0R0T	RES , CHIP	0 ohm 1/16W 0% 0603
R1320	CRJ10DJ473T	RES , CHIP	47K ohm 1/16W 5% 0603
R1321	CRJ10DJ471T	RES , CHIP	470 ohm 1/16W 5% 0603
R1322	CRJ10DJ222T	RES , CHIP	2K2 ohm 1/16W 5% 0603
R1323	CRJ10DJ222T	RES , CHIP	2K2 ohm 1/16W 5% 0603
R1324	CRJ10DJ473T	RES , CHIP	47K ohm 1/16W 5% 0603
R1325	CRJ10DJ471T	RES , CHIP	470 ohm 1/16W 5% 0603
R1326	CRJ10DJ473T	RES , CHIP	47K ohm 1/16W 5% 0603
R1327	CRJ10DJ473T	RES , CHIP	47K ohm 1/16W 5% 0603
R1328	CRJ10DJ471T	RES , CHIP	470 ohm 1/16W 5% 0603
R1329	CRJ10DJ471T	RES , CHIP	470 ohm 1/16W 5% 0603
R1330	CRJ10DJ471T	RES , CHIP	470 ohm 1/16W 5% 0603
R1331	CRJ10DJ471T	RES , CHIP	470 ohm 1/16W 5% 0603
R1332	CRJ10DJ471T	RES , CHIP	470 ohm 1/16W 5% 0603
R1333	CRJ10DJ471T	RES , CHIP	470 ohm 1/16W 5% 0603
R1334	CRJ10DJ471T	RES , CHIP	470 ohm 1/16W 5% 0603
R1335	CRJ10DJ471T	RES , CHIP	470 ohm 1/16W 5% 0603
R1336	CRJ10DJ473T	RES , CHIP	47K ohm 1/16W 5% 0603
R1337	CRJ10DJ104T	RES , CHIP	100K ohm 1/16W 5% 0603
R1338	CRJ10DJ473T	RES , CHIP	47K ohm 1/16W 5% 0603
R1339	CRJ10DJ104T	RES , CHIP	100K ohm 1/16W 5% 0603
R1340	CRJ10DJ104T	RES , CHIP	100K ohm 1/16W 5% 0603
R1341	CRJ10DJ104T	RES , CHIP	100K ohm 1/16W 5% 0603
R1342	CRJ10DJ104T	RES , CHIP	100K ohm 1/16W 5% 0603
R1343	CRJ10DJ104T	RES , CHIP	100K ohm 1/16W 5% 0603
R1344	CRJ10DJ473T	RES , CHIP	47K ohm 1/16W 5% 0603
R1345	CRJ10DJ473T	RES , CHIP	47K ohm 1/16W 5% 0603
R1347	CRJ10DJ473T	RES , CHIP	47K ohm 1/16W 5% 0603
R1354	CRJ10DJ473T	RES , CHIP	47K ohm 1/16W 5% 0603

Ref. Designator	Part Number	Description	Qty
PROCESSOR PCB ASS'Y		COP12042B	
R1359	CRJ10DJ473T	RES , CHIP	47K ohm 1/16W 5% 0603
R1366	CRJ10DJ473T	RES , CHIP	47K ohm 1/16W 5% 0603
R1367	CRJ10DJ473T	RES , CHIP	47K ohm 1/16W 5% 0603
R1368	CRJ10DJ473T	RES , CHIP	47K ohm 1/16W 5% 0603
R1369	CRJ10DJ104T	RES , CHIP	100K ohm 1/16W 5% 0603
R1370	CRJ10DJ104T	RES , CHIP	100K ohm 1/16W 5% 0603
R1371	CRJ10DJ102T	RES , CHIP	1K ohm 1/16W 5% 0603
R1372	CRJ10DJ104T	RES , CHIP	100K ohm 1/16W 5% 0603
R1373	CRJ10DJ102T	RES , CHIP	1K ohm 1/16W 5% 0603
R1374	CRJ10DJ104T	RES , CHIP	100K ohm 1/16W 5% 0603
R1375	CRJ10DJ104T	RES , CHIP	100K ohm 1/16W 5% 0603
R1376	CRJ10DJ104T	RES , CHIP	100K ohm 1/16W 5% 0603
R1377	CRJ10DJ473T	RES , CHIP	47K ohm 1/16W 5% 0603
R1378	CRJ10DJ102T	RES , CHIP	1K ohm 1/16W 5% 0603
R1379	CRJ10DJ102T	RES , CHIP	1K ohm 1/16W 5% 0603
R1380	CRJ10DJ104T	RES , CHIP	100K ohm 1/16W 5% 0603
R1381	CRJ10DJ102T	RES , CHIP	1K ohm 1/16W 5% 0603
R1382	CRJ10DJ104T	RES , CHIP	100K ohm 1/16W 5% 0603
R1383	CRJ10DJ102T	RES , CHIP	1K ohm 1/16W 5% 0603
R1384	CRJ10DJ471T	RES , CHIP	470 ohm 1/16W 5% 0603
R1385	CRJ10DJ471T	RES , CHIP	470 ohm 1/16W 5% 0603
R1386	CRJ10DJ473T	RES , CHIP	47K ohm 1/16W 5% 0603
R1387	CRJ10DJ473T	RES , CHIP	47K ohm 1/16W 5% 0603
R1388	CRJ10DJ104T	RES , CHIP	100K ohm 1/16W 5% 0603
R1389	CRJ10DJ104T	RES , CHIP	100K ohm 1/16W 5% 0603
R1390	CRJ10DJ473T	RES , CHIP	47K ohm 1/16W 5% 0603
R1391	CRJ10DJ473T	RES , CHIP	47K ohm 1/16W 5% 0603
R1392	CRJ10DJ473T	RES , CHIP	47K ohm 1/16W 5% 0603
R1393	CRJ10DJ473T	RES , CHIP	47K ohm 1/16W 5% 0603
R1394	CRJ10DJ473T	RES , CHIP	47K ohm 1/16W 5% 0603
R1395	CRJ10DJ473T	RES , CHIP	47K ohm 1/16W 5% 0603
R1396	CRJ10DJ104T	RES , CHIP	100K ohm 1/16W 5% 0603
R1397	CRJ10DJ104T	RES , CHIP	100K ohm 1/16W 5% 0603
R1398	CRJ10DJ473T	RES , CHIP	47K ohm 1/16W 5% 0603
R1399	CRJ10DJ473T	RES , CHIP	47K ohm 1/16W 5% 0603
R1400	CRJ10DJ221T	RES , CHIP	220 ohm 1/16W 5% 0603
R1401	CRJ10DJ473T	RES , CHIP	47K ohm 1/16W 5% 0603
R1402	CRJ10DJ221T	RES , CHIP	220 ohm 1/16W 5% 0603
R1403	CRJ10DJ473T	RES , CHIP	47K ohm 1/16W 5% 0603
R1404	CRJ10DJ221T	RES , CHIP	220 ohm 1/16W 5% 0603
R1405	CRJ10DJ221T	RES , CHIP	220 ohm 1/16W 5% 0603
R1406	CRJ10DJ473T	RES , CHIP	47K ohm 1/16W 5% 0603
R1411	CRJ10DJ471T	RES , CHIP	470 ohm 1/16W 5% 0603
R1412	CRJ10DJ471T	RES , CHIP	470 ohm 1/16W 5% 0603
R1413	CRJ10DJ222T	RES , CHIP	2K2 ohm 1/16W 5% 0603
R1414	CRJ10DJ222T	RES , CHIP	2K2 ohm 1/16W 5% 0603
R1000	CRJ10DJ222T	RES , CHIP	2K2 ohm 1/16W 5% 0603
R1001	CRJ10DJ222T	RES , CHIP	2K2 ohm 1/16W 5% 0603
R1002	CRJ10DJ222T	RES , CHIP	2K2 ohm 1/16W 5% 0603
R1003	CRJ10DJ222T	RES , CHIP	2K2 ohm 1/16W 5% 0603
R1004	CRJ10DJ222T	RES , CHIP	2K2 ohm 1/16W 5% 0603
R1005	CRJ10DJ222T	RES , CHIP	2K2 ohm 1/16W 5% 0603
R1008	CRJ10DJ753T	RES , CHIP	75K ohm 1/16W 5% 0603
R1009	CRJ10DJ104T	RES , CHIP	100K ohm 1/16W 5% 0603
R1010	CRJ10DJ104T	RES , CHIP	100K ohm 1/16W 5% 0603
R1011	CRJ10DJ102T	RES , CHIP	1K ohm 1/16W 5% 0603
R1012	CRJ10DJ102T	RES , CHIP	1K ohm 1/16W 5% 0603
R1013	CRJ10DJ102T	RES , CHIP	1K ohm 1/16W 5% 0603
R1014	CRJ10DJ102T	RES , CHIP	1K ohm 1/16W 5% 0603
R1015	CRJ10DJ102T	RES , CHIP	1K ohm 1/16W 5% 0603
R1016	CRJ10DJ222T	RES , CHIP	2K2 ohm 1/16W 5% 0603
R1017	CRJ10DJ222T	RES , CHIP	2K2 ohm 1/16W 5% 0603
R1018	CRJ10DJ222T	RES , CHIP	2K2 ohm 1/16W 5% 0603
R1019	CRJ10DJ222T	RES , CHIP	2K2 ohm 1/16W 5% 0603
R1020	CRJ10DJ104T	RES , CHIP	100K ohm 1/16W 5% 0603
R1021	CRJ10DJ104T	RES , CHIP	100K ohm 1/16W 5% 0603
R1022	CRJ10DJ332T	RES , CHIP	3K3 ohm 1/16W 5% 0603
R1023	CRJ10DJ332T	RES , CHIP	3K3 ohm 1/16W 5% 0603
R1024	CRJ10DJ332T	RES , CHIP	3K3 ohm 1/16W 5% 0603
R1025	CRJ10DJ332T	RES , CHIP	3K3 ohm 1/16W 5% 0603
R1026	CRJ10DJ123T	RES , CHIP	12K ohm 1/16W 5% 0603

Ref. Designator	Part Number	Description	Qty
PROCESSOR PCB ASS'Y		COP12042B	
R1027	CRJ10DJ123T	RES , CHIP	12K ohm 1/16W 5% 0603
R1028	CRJ10DJ102T	RES , CHIP	1K ohm 1/16W 5% 0603
R1029	CRJ10DJ103T	RES , CHIP	10K ohm 1/16W 5% 0603
R1030	CRJ10DJ103T	RES , CHIP	10K ohm 1/16W 5% 0603
R1031	CRJ10DJ222T	RES , CHIP	2K2 ohm 1/16W 5% 0603
R1032	CRJ10DJ102T	RES , CHIP	1K ohm 1/16W 5% 0603
R1033	CRJ10DJ102T	RES , CHIP	1K ohm 1/16W 5% 0603
R1034	CRJ10DJ152T	RES , CHIP	1K5 ohm 1/16W 5% 0603
R1035	CRJ10DJ152T	RES , CHIP	1K5 ohm 1/16W 5% 0603
R1036	CRJ10DJ102T	RES , CHIP	1K ohm 1/16W 5% 0603
R1037	CRJ10DJ102T	RES , CHIP	1K ohm 1/16W 5% 0603
R1038	CRJ10DJ102T	RES , CHIP	1K ohm 1/16W 5% 0603
R1039	CRJ10DJ102T	RES , CHIP	1K ohm 1/16W 5% 0603
R1040	CRJ10DJ912T	RES , CHIP	9K1 ohm 1/16W 5% 0603
R1045	CRJ10DJ102T	RES , CHIP	1K ohm 1/16W 5% 0603
R1046	CRJ10DJ102T	RES , CHIP	1K ohm 1/16W 5% 0603
R1047	CRJ10DJ104T	RES , CHIP	100K ohm 1/16W 5% 0603
R1048	CRJ10DJ104T	RES , CHIP	100K ohm 1/16W 5% 0603
R1049	CRJ10DJ104T	RES , CHIP	100K ohm 1/16W 5% 0603
R1051	CRJ10DJ102T	RES , CHIP	1K ohm 1/16W 5% 0603
R1052	CRJ10DJ102T	RES , CHIP	1K ohm 1/16W 5% 0603
R1053	CRJ10DJ202T	RES , CHIP	2K ohm 1/16W 5% 0603
R1055	CRJ10DJ104T	RES , CHIP	100K ohm 1/16W 5% 0603
R1056	CRJ10DJ104T	RES , CHIP	100K ohm 1/16W 5% 0603
R1057	CRJ10DJ102T	RES , CHIP	1K ohm 1/16W 5% 0603
R1058	CRJ10DJ102T	RES , CHIP	1K ohm 1/16W 5% 0603
R1059	CRJ10DJ102T	RES , CHIP	1K ohm 1/16W 5% 0603
R1065	CRJ10DJ104T	RES , CHIP	100K ohm 1/16W 5% 0603
R1066	CRJ10DJ104T	RES , CHIP	100K ohm 1/16W 5% 0603
R1067	CRJ10DJ104T	RES , CHIP	100K ohm 1/16W 5% 0603
R1068	CRJ10DJ104T	RES , CHIP	100K ohm 1/16W 5% 0603
R1070	CRJ10DJ102T	RES , CHIP	1K ohm 1/16W 5% 0603
R1071	CRJ10DJ102T	RES , CHIP	1K ohm 1/16W 5% 0603
R1072	CRJ10DJ102T	RES , CHIP	1K ohm 1/16W 5% 0603
R1073	CRJ10DJ102T	RES , CHIP	1K ohm 1/16W 5% 0603
R1074	CRJ10DJ102T	RES , CHIP	1K ohm 1/16W 5% 0603
R1075	CRJ10DJ102T	RES , CHIP	1K ohm 1/16W 5% 0603
R1077	CRJ10DJ562T	RES , CHIP	5K6 ohm 1/16W 5% 0603
R1078	CRJ10DJ562T	RES , CHIP	5K6 ohm 1/16W 5% 0603
R1079	CRJ10DJ562T	RES , CHIP	5K6 ohm 1/16W 5% 0603
R1080	CRJ10DJ152T	RES , CHIP	1K5 ohm 1/16W 5% 0603
R1081	CRJ10DJ152T	RES , CHIP	1K5 ohm 1/16W 5% 0603
R1082	CRJ10DJ103T	RES , CHIP	10K ohm 1/16W 5% 0603
R1083	CRJ10DJ562T	RES , CHIP	5K6 ohm 1/16W 5% 0603
R1084	CRJ10DJ562T	RES , CHIP	5K6 ohm 1/16W 5% 0603
R1085	CRJ10DJ152T	RES , CHIP	1K5 ohm 1/16W 5% 0603
R1086	CRJ10DJ432T	RES , CHIP	4K3 ohm 1/16W 5% 0603
R1087	CRJ10DJ152T	RES , CHIP	1K5 ohm 1/16W 5% 0603
R1088	CRJ10DJ432T	RES , CHIP	4K3 ohm 1/16W 5% 0603
R1089	CRJ10DJ222T	RES , CHIP	2K2 ohm 1/16W 5% 0603
R1090	CRJ10DJ222T	RES , CHIP	2K2 ohm 1/16W 5% 0603
R1091	CRJ10DJ222T	RES , CHIP	2K2 ohm 1/16W 5% 0603
R1092	CRJ10DJ222T	RES , CHIP	2K2 ohm 1/16W 5% 0603
R1093	CRJ10DJ222T	RES , CHIP	2K2 ohm 1/16W 5% 0603
R1094	CRJ10DJ222T	RES , CHIP	2K2 ohm 1/16W 5% 0603
R1095	CRJ10DJ222T	RES , CHIP	2K2 ohm 1/16W 5% 0603
R1096	CRJ10DJ222T	RES , CHIP	2K2 ohm 1/16W 5% 0603
R1097	CRJ10DJ222T	RES , CHIP	2K2 ohm 1/16W 5% 0603
R1098	CRJ10DJ222T	RES , CHIP	2K2 ohm 1/16W 5% 0603
R1407	CRJ10DJ202T	RES , CHIP	2K ohm 1/16W 5% 0603
R1408	CRJ10DJ202T	RES , CHIP	2K ohm 1/16W 5% 0603
R1409	CRJ10DJ202T	RES , CHIP	2K ohm 1/16W 5% 0603
R1410	CRJ10DJ202T	RES , CHIP	2K ohm 1/16W 5% 0603
<i>Miscellaneous</i>			
JA1001	CJJ4R020Z	JACK , BOARD	GOLD. PLATE
JA1002	CJJ4R020Z	JACK , BOARD	GOLD. PLATE
JA1003	CJJ4P019Y	JACK , BOARD	GOLD , PLATE
JA1004	CJJ4M062Z	JACK , RCA (1P, 115AG, PP, AU PL)	RCA-115AGG-06
K1000	CSL4C010ZE	RELAY , D3009(1-1462033-4) , TYCO	D3009(1-1462033-4)

Ref. Designator	Part Number	Description		Qty
PROCESSOR PCB ASS'Y		COP12042B		
N1003	CJP07GB99ZY	HOUSING	35237-0710 2.0mm 7P WHT	1
N1004	CJP10GB99ZY	WAFER	35237-1010 2.0mm 10P WHT	1
N1005	CJP10GB99ZY	WAFER	35237-1010 2.0mm 10P WHT	1
P1002	CJP10GA47ZW	WAFER, 2mm	GIL-S-10P-S2T2-EF 10P	1
P1003	CJP11GA98ZM	WAFER	35336-1110 2.0mm 11P WHT	1
P1004	CJP04GA47ZW	WAFER(4P, ST 2MM)	GIL-S-4P-S2T2-EF 4P	1
P1005	CJP05GA47ZW	WAFER,2mm	GIL-S-5P-S2T2-EF 5P	1
P1006	CJP19GA98ZM	WAFER(19P, ST 2MM)	35336-1910 2.0mm 19P WHT	1
P1007	CJP05GA47ZW	WAFER,2mm	GIL-S-5P-S2T2-EF 5P	1
P1008	CJP19GA98ZM	WAFER(19P, ST 2MM)	35336-1910 2.0mm 19P WHT	1
P1009	CJP19GA98ZM	WAFER(19P, ST 2MM)	35336-1910 2.0mm 19P WHT	1
P1010	CJP10GA98ZY	WAFER	35336-1010 2.0mm 10P WHT	1
P1011	CJP04GA47ZW	WAFER(4P, ST 2MM)	GIL-S-4P-S2T2-EF 4P	1
POWER PCB ASS'Y		COP12043B		
<i>Capacitors</i>				
C3207	CCUS1H104KC	CAP , CHIP	0.1UF 50V K	1
C3251	CCUS1H104KC	CAP , CHIP	0.1UF 50V K	1
C3253	CCUS1H104KC	CAP , CHIP	0.1UF 50V K	1
C3255	CCUS1H104KC	CAP , CHIP	0.1UF 50V K	1
C3256	CCUS1H104KC	CAP , CHIP	0.1UF 50V K	1
C3257	CCUS1H104KC	CAP , CHIP	0.1UF 50V K	1
C3258	CCUS1H104KC	CAP , CHIP	0.1UF 50V K	1
C3259	CCUS1H104KC	CAP , CHIP	0.1UF 50V K	1
C3002	CCFT1H103ZF	CAP , CERAMIC	0.01UF 50V Z	1
C3003	CCFT1H103ZF	CAP , CERAMIC	0.01UF 50V Z	1
C3004	CCFT1H103ZF	CAP , CERAMIC	0.01UF 50V Z	1
C3007	CCEA1EH471T	CAP , ELECT	470UF 25V	1
C3008	CCFT1H103ZF	CAP , CERAMIC	0.01UF 50V Z	1
C3009	CCFT1H103ZF	CAP , CERAMIC	0.01UF 50V Z	1
C3010	CCFT1H103ZF	CAP , CERAMIC	0.01UF 50V Z	1
C3011	CCEA1EH471T	CAP , ELECT	470UF 25V	1
C3013	CCBS1H104ZFT	CAP , CERAMIC	0.1UF 50V Z	1
C3014	CCEA1HH1R0T	CAP , ELECT	1UF 50V	1
C3015	CCBS1H104ZFT	CAP , CERAMIC	0.1UF 50V Z	1
C3018	CCBS1H104ZFT	CAP , CERAMIC	0.1UF 50V Z	1
C3019	CCEA1HH100T	CAP , ELECT	10UF 50V	1
C3020	CCEA1HH100T	CAP , ELECT	10UF 50V	1
C3021	CCBS1H104ZFT	CAP , CERAMIC	0.1UF 50V Z	1
C3090	CCME2A473JXT	CAP , METALLIZED FILM	47NF 100V 20% CPM	1
C3091	CCME2A473JXT	CAP , METALLIZED FILM	47NF 100V 20% CPM	1
C3092	CCME2A473JXT	CAP , METALLIZED FILM	47NF 100V 20% CPM	1
C3103	KCME2E104JP04T	CAP , METALLIZED FILM	100NF 250V 20% CPM	1
C3104	KCME2E104JP04T	CAP , METALLIZED FILM	100NF 250V 20% CPM	1
C3105	KCME2E104JP04T	CAP , METALLIZED FILM	100NF 250V 20% CPM	1
C3252	CCEA1CH101T	CAP , ELECT	100UF 16V	1
C3254	CCFT1H104ZF	CAP , SEMICONDUCTOR	0.1UF 50V Z	1
C3000	HCQE2E104KDE	CAP , LINE ACROSS	CPPMX 100NOF +20% -20%	1
C3001	KCKDKS472ME	CAP , CERAMIC(X1/Y2/SC)	0.0047UF/2.5KV	1
C3005	CCEA1JH471E	CAP , ELECT	470uF 63V +20% 85C	1
C3006	CCEA1JH471E	CAP , ELECT	470uF 63V +20% 85C	1
C3016	CCEA1HH221E	CAP , ELECT	50V 220UF 10*12	1
C3025	CCEA1EH681ES	E.CAP 25V 680uF, 105°C	680uF 25V +20% 85C	1
C3101	CCET63VKL5103NK	CAP , ELECT	10000uF 63V M 30x40 LSW103M1JP45M	1
C3102	CCET63VKL5103NK	CAP , ELECT	10000uF 63V M 30x40 LSW103M1JP45M	1
<i>Semiconductors</i>				
D3001	HVD1N4148T	DIODE	1N4148	1
D3002	HVD1N4007T	DIODE	1N4007 1000V 1A DO-41	1
D3003	HVD1N4007T	DIODE	1N4007 1000V 1A DO-41	1
D3004	CVDZJ9.1BT	DIODE , ZENER	MZ0.5GE9V1-20 9.1V 20mA	1
D3005	HVD1N4007T	DIODE	1N4007 1000V 1A DO-41	1
D3006	HVD1N4007T	DIODE	1N4007 1000V 1A DO-41	1
D3007	HVD1N4007T	DIODE	1N4007 1000V 1A DO-41	1
D3008	HVD1N4007T	DIODE	1N4007 1000V 1A DO-41	1
D3009	HVD1N4007T	DIODE	1N4007 1000V 1A DO-41	1
D3010	HVD1N5819T	DIODE , SCHOTTKY	1N5819	1
D3011	HVD1N4148T	DIODE	1N4148 100V 150E-3A	1

Ref. Designator	Part Number	Description		Qty
POWER PCB ASS'Y		COP12043B		
D3012	HVD1N4007T	DIODE	1N4007 1000V 1A DO-41	1
D3013	HVD1N4007T	DIODE	1N4007 1000V 1A DO-41	1
D3016	CVDZJ4.3BT	DIODE , ZENER	MZ0.5GE4V3-20 4.3V 20mA	1
D3017	HVD1N4007T	DIODE	1N4007 1000V 1A DO-41	1
D3018	HVD1N4007T	DIODE	1N4007 1000V 1A DO-41	1
D3019	CVDZJ22BT	DIODE , ZENER	MZ0.5GE22V-5 22V 5mA	1
D3020	CVDZJ22BT	DIODE , ZENER	MZ0.5GE22V-5 22V 5mA	1
D3021	HVD1N4007T	DIODE	1N4007 1000V 1A DO-41	1
D3200	CVDPG05GBUSCRTPK	DIODE , ESD PROTECTION USC	PG05GBUSC-RTK/P , KEC	1
D3203	CVDPG05GBUSCRTPK	DIODE , ESD PROTECTION USC	PG05GBUSC-RTK/P , KEC	1
D3204	CVDPG05GBUSCRTPK	DIODE , ESD PROTECTION USC	PG05GBUSC-RTK/P , KEC	1
D3205	CVDPG05GBUSCRTPK	DIODE , ESD PROTECTION USC	PG05GBUSC-RTK/P , KEC	1
D3206	CVDPG05GBUSCRTPK	DIODE , ESD PROTECTION USC	PG05GBUSC-RTK/P , KEC	1
D3210	CVDPG05GBUSCRTPK	DIODE , ESD PROTECTION USC	PG05GBUSC-RTK/P , KEC	1
D3211	CVDPG05GBUSCRTPK	DIODE , ESD PROTECTION USC	PG05GBUSC-RTK/P , KEC	1
D3212	CVDPG05GBUSCRTPK	DIODE , ESD PROTECTION USC	PG05GBUSC-RTK/P , KEC	1
D3251	HVD1SS355T	DIODE , CHIP	1SS355TE-17	1
D3252	HVDUDZS15BSR	DIODE , ZENER 15B 15V 200MW UMD2 ROHM	UDZS 15B 15V 200mW UMD2	1
D3253	HVDUDZS15BSR	DIODE , ZENER 15B 15V 200MW UMD2 ROHM	UDZS 15B 15V 200mW UMD2	1
D3254	HVDUDZS15BSR	DIODE , ZENER 15B 15V 200MW UMD2 ROHM	UDZS 15B 15V 200mW UMD2	1
D3255	HVDUDZS15BSR	DIODE , ZENER 15B 15V 200MW UMD2 ROHM	UDZS 15B 15V 200mW UMD2	1
D3256	HVD1SS355T	DIODE , CHIP	1SS355TE-17	1
D3257	HVD1SS355T	DIODE , CHIP	1SS355TE-17	1
IC3251	CVIMAX3223CDWR	I.C , RS-232 LINE DIRVER SOIC-16P	MAX3223CDWR SOIC16P	1
Q3001	CVTMPA06ATPF	TRANSISTOR , DRIVER(NPN,120V, 500mA TO-92)	MPSA06-AT/PF , KEC	1
Q3002	CVTMPA06ATPF	TRANSISTOR , DRIVER(NPN,120V, 500mA TO-92)	MPSA06-AT/PF , KEC	1
	CVIBA033T0I2	I.C , REGULATOR LOW DROP(3.3V, 2W, TO-220)	BA033T , ROHM	1
	HVJIA78R05PI	REGULATOR (5V OUTPUT LOW DROP)	KIA78R05PI	1
	CVDRS1004	DIODE , BRIDGE(RS-10)	RS1004 RS-10	1
	CVDKBU6GMFRS6	DIODE , BRIDGE(RS-6 KINK TYPE)	KBU6GMFRS6 , DELTA	1
D3090	CVDKBU6GMFRS6ZA	DIODE , HEAT SINK ASS'Y (CMY2A294+KBU6GMF)	KBU6GMF+CMY2A294	1
D3101	CVDRS1004ZA	DIODE HEAT SINK ASS'Y	RS1004+CMY2A294 , DELTA	1
<i>Resistors</i>				
R3212	CRJ10DF7502T	RES , CHIP(75K, 1608, 1%)	75K, 1608, 1%	1
R3213	CRJ10DF7502T	RES , CHIP(75K, 1608, 1%)	75K, 1608, 1%	1
R3214	CRJ10DF4992T	RES , CHIP(49.9K, 1608, 1%)	49.9K, 1608, 1%	1
R3215	CRJ10DF4992T	RES , CHIP(49.9K, 1608, 1%)	49.9K, 1608, 1%	1
R3241	CRJ10DJ0R0T	RES , CHIP	0 ohm 1/16W 0% 0603	1
R3251	CRJ10DJ472T	RES , CHIP	4K7ohm 1/16W 5% 0603	1
R3252	CRJ10DJ472T	RES , CHIP	4K7ohm 1/16W 5% 0603	1
R3253	CRJ10DJ472T	RES , CHIP	4K7ohm 1/16W 5% 0603	1
R3002	CRD20TJ103T	RES , CARBON	10K OHM 1/5W J	1
R3003	CRD20TJ102T	RES , CARBON	1K OHM 1/5W J	1
R3004	CRD20TJ153T	RES , CARBON	15K OHM 1/5W J	1
R3005	CRD20TJ222T	RES , CARBON	2.2K OHM 1/5W J	1
R3006	CRD20TJ1R0T	RES , CARBON	1 OHM 1/5W J	1
R3007	CRD20TJ1R0T	RES , CARBON	1 OHM 1/5W J	1
R3009	CRD20TJ103T	RES , CARBON	10K OHM 1/5W J	1
R3010	CRD20TJ104T	RES , CARBON	100K OHM 1/5W J	1
R3011	CRD20TJ562T	RES , CARBON	5.6K OHM 1/5W J	1
R3012	CRD20TJ272T	RES , CARBON	2.7K OHM 1/5W J	1
R3013	CRD20TJ470T	RES , CARBON	47 OHM 1/5W J	1
R3020	CRD20TJ103T	RES , CARBON	10K OHM 1/5W J	1
R3021	CRD20TJ473T	RES , CARBON	47K OHM 1/5W J	1
R3022	CRD20TJ473T	RES , CARBON	47K OHM 1/5W J	1
R3023	CRD20TJ473T	RES , CARBON	47K OHM 1/5W J	1
R3024	CRD20TJ473T	RES , CARBON	47K OHM 1/5W J	1
R3025	CRD20TJ473T	RES , CARBON	47K OHM 1/5W J	1
R3026	CRD20TJ473T	RES , CARBON	47K OHM 1/5W J	1
R3008	CRG2ANJ330H	RES , METAL OXIDE FILM	33 OHM 2W J	1
R3014	CRG1ANJ4R7H	RES , METAL OXIDE FILM	4.7 OHM 1W J	1
R3015	CRG1ANJ4R7H	RES , METAL OXIDE FILM	4.7 OHM 1W J	1
R3016	CRG1ANJ100H	RES , METAL OXIDE FILM	10 OHM 1W J	1
<i>Miscellaneous</i>				
G3000	HJT1A025	PLATE , EARTH	MET37-0002	1
G3001	HJT1A025	PLATE , EARTH	MET37-0002	1
	CVIAVR755PBGA	I.C HEAT SINK ASS'Y(CMY2A239)		1

Ref. Designator	Part Number	Description		Qty
POWER PCB ASS'Y		COP12043B		
	CHD1A012R	SCREW , SPECIAL		1
	CMY2A239	HEAT SINK , AVR755		1
	CTB3+8JR	SCREW		1
FH3000	KJCF5S	HOLDER , FUSE	J4210020001X	1
FH3002	KJCF5S	HOLDER , FUSE	J4210020001X	1
FH3100	KJCF5S	HOLDER , FUSE	J4210020001X	1
FH3101	KJCF5S	HOLDER , FUSE	J4210020001X	1
F3010	CBA2D4000A2EYT	FUSE (LITTLE FUSE 382 SERIES) 4A 250V		1
F3011	CBA2D4000A2EYT	FUSE (LITTLE FUSE 382 SERIES) 4A 250V		1
BD3251	CLZ9R012Z	BEAD , FERRITE(FCM2012CF-301T04 300ohm)	FCM2012CF-301T0	1
BD3252	CLZ9R012Z	BEAD , FERRITE(FCM2012CF-301T04 300ohm)	FCM2012CF-301T0	1
BD3253	CLZ9R012Z	BEAD , FERRITE(FCM2012CF-301T04 300ohm)	FCM2012CF-301T0	1
	CHD5A012JR	SCREW		1
	CMY2A294	HEAT SINK , DIODE AVR755		1
	CHD5A012JR	SCREW		1
	CMY2A294	HEAT SINK , DIODE AVR755		1
HK3251	CMC1A337	BRACKET , GND SMALL AVR755		1
JA3000	CJJ8A007ZD	JACK , AC INLET(2P, AC054P020A,10A, 250V)	AC054P020A	1
JA3001	KJJ7A013Z	OUTLET , AC 1 PIN USA	A202D0031P(1P)	1
JA3201	CJJ9L010Z	JACK , IPOD CONNECTOR	MOLEX SD-52986-020	1
JA3251	CJJ9W001Z	JACK , 9P D-SUB FEMALE(RS-232C, SEMCO)	JACK D-SUB 9P 87204-6063 W/DUST COVER BK	1
N3007	CWB1B004250GN	WIRE , ASS'Y		1
N3018	CWBAVR755N102	3P WIRE ASS'Y(400MM, 3.96MM)		1
N3206	CJP11GB99ZM	WAFER	35237-1110 2.0mm 11P WHT	1
P3001	CJP03GA90ZY	WAFER	35313-0310 3.96mm 3P	1
P3002	CJP05GA01ZY	WAFER(YMW025-05R)	5267-05A 2.5mm 5P WHT	1
P3003	CJP11GA47ZW	WAFER(11P, ST 2MM)	GIL-S-11P-S2T2-EF 11P	1
P3004	CJP06GA90ZM	WAFER(6P, 3.96MM)	35313-0610 3.96mm 6P	1
P3005	CJP02GA89ZM	WAFER	35328-0210 7.92mm 2P WHT	1
P3006	CJP02KA060ZY	WAFER	YW396-03V 7.92mm 2P	1
P3018	CJP06GA01ZY	WAFER , 6PIN		1
P3205	CJP05GA47ZW	WAFER,2mm	GIL-S-5P-S2T2-EF 5P	1
P3250	CJP04GA47ZW	WAFER(4P, ST 2MM)	GIL-S-4P-S2T2-EF 4P	1
RY3000	HSL1A008ZE	RELAY	SDT-S-112DMR	1
T3001	CLT5L058ZU	TRANS , SUB(RV5, UL,120V 60Hz)	RV5(UL) , SEO KYUNG	1
VIDEO PCB ASS'Y		COP12045B		1
<i>Capacitors</i>				
C1524	CCUS1H331JA	CAP , CHIP	330PF 50V J	1
C1530	CCUS1H331JA	CAP , CHIP	330PF 50V J	1
C1531	CCUS1H561JA	CAP , CHIP	560PF 50V J	1
C1533	CCUS1H331JA	CAP , CHIP	330PF 50V J	1
C1575	CCUS1H471JA	CAP , CHIP	470PF 50V J	1
C1576	CCUS1H101JA	CAP , CHIP	100PF 50V J	1
C1577	CCUS1H101JA	CAP , CHIP	100PF 50V J	1
C1578	CCUS1H101JA	CAP , CHIP	100PF 50V J	1
C1579	CCUS1H104KC	CAP , CHIP	0.1UF 50V K	1
C1580	CCUS1H103KC	CAP , CHIP	0.01UF 50V K	1
C1583	CCUS1H104KC	CAP , CHIP	0.1UF 50V K	1
C1585	CCUS1H103KC	CAP , CHIP	0.01UF 50V K	1
C1588	CCUS1H300JA	CAP , CHIP	30pF +/-5% 50V COG 0603	1
C1589	CCUS1H270JA	CAP , CHIP	27PF 50V J	1
C1590	CCUS1H100JA	CAP , CHIP	10PF 50V J	1
C1593	CCUS1H103KC	CAP , CHIP	0.01UF 50V K	1
C1594	CCUS1H103KC	CAP , CHIP	0.01UF 50V K	1
C1596	CCUS1H390JA	CAP , CHIP	39PF 50V J	1
C1597	CCUS1H390JA	CAP , CHIP	39PF 50V J	1
C1598	CCUS1H390JA	CAP , CHIP	39PF 50V J	1
C1599	CCUS1H390JA	CAP , CHIP	39PF 50V J	1
C1601	CCUS1H101JA	CAP , CHIP	100PF 50V J	1
C1602	CCUS1H101JA	CAP , CHIP	100PF 50V J	1
C1603	CCUS1H101JA	CAP , CHIP	100PF 50V J	1
C1606	CCUS1H104KC	CAP , CHIP	0.1UF 50V K	1
C1609	CCUS1H101JA	CAP , CHIP	100PF 50V J	1
C1610	CCUS1H101JA	CAP , CHIP	100PF 50V J	1
C1611	CCUS1H101JA	CAP , CHIP	100PF 50V J	1
C1613	CCUS1H104KC	CAP , CHIP	0.1UF 50V K	1
C1615	CCUS1H104KC	CAP , CHIP	0.1UF 50V K	1
C1622	CCUS1H104KC	CAP , CHIP	0.1UF 50V K	1

Ref. Designator	Part Number	Description	Qty
VIDEO PCB ASS'Y		COP12045B	
C1623	CCUS1H104KC	CAP , CHIP	0.1UF 50V K
C1656	CCUS1H104KC	CAP , CHIP	0.1UF 50V K
C1660	CCUS1H104KC	CAP , CHIP	0.1UF 50V K
C1664	CCUS1H104KC	CAP , CHIP	0.1UF 50V K
C1501	CCEA1AH221T	CAP , ELECT	220UF 10V
C1502	CCEA1HH100T	CAP , ELECT	10UF 50V
C1503	CCEA1AH221T	CAP , ELECT	220UF 10V
C1504	CCEA1AH221T	CAP , ELECT	220UF 10V
C1505	CCEA1AH221T	CAP , ELECT	220UF 10V
C1506	CCEA1HH100T	CAP , ELECT	10UF 50V
C1507	CCEA1AH221T	CAP , ELECT	220UF 10V
C1508	CCEA1AH221T	CAP , ELECT	220UF 10V
C1509	CCEA1HH100T	CAP , ELECT	10UF 50V
C1510	CCEA1AH221T	CAP , ELECT	220UF 10V
C1511	CCEA1AH471T	CAP , ELECT	470UF 10V
C1512	CCEA1AH471T	CAP , ELECT	470UF 10V
C1513	CCEA1AH471T	CAP , ELECT	470UF 10V
C1514	CCEA1AH471T	CAP , ELECT	470UF 10V
C1515	CCEA1AH471T	CAP , ELECT	470UF 10V
C1516	CCEA1AH471T	CAP , ELECT	470UF 10V
C1517	CCEA1AH471T	CAP , ELECT	470UF 10V
C1518	CCEA1AH471T	CAP , ELECT	470UF 10V
C1519	CCEA1AH221T	CAP , ELECT	220UF 10V
C1520	CCEA1AH221T	CAP , ELECT	220UF 10V
C1521	CCEA1AH221T	CAP , ELECT	220UF 10V
C1522	CCEA1HH100T	CAP , ELECT	10UF 50V
C1523	CCEA1HH100T	CAP , ELECT	10UF 50V
C1528	CCEA1HH100T	CAP , ELECT	10UF 50V
C1529	CCEA1CH101T	CAP , ELECT	100UF 16V
C1532	CCEA1HH100T	CAP , ELECT	10UF 50V
C1566	CCEA0JH102T	CAP , ELECT	1000UF 6.3V
C1567	CCEA0JH102T	CAP , ELECT	1000UF 6.3V
C1568	CCEA1CH470T	CAP , ELECT	47UF 16V
C1572	CCEA1AH221T	CAP , ELECT	220UF 10V
C1573	CCEA1AH221T	CAP , ELECT	220UF 10V
C1574	CCEA0JH102T	CAP , ELECT	1000UF 6.3V
C1581	CCEA1HH2R2T	CAP , ELECT	2.2UF 50V
C1582	CCEA1HH100T	CAP , ELECT	10UF 50V
C1584	CCEA1AH101T	CAP , ELECT	100UF 10V
C1586	CCEA1HH1R0T	CAP , ELECT	1UF 50V
C1587	HCQI1H223JZT	CAP , MYLAR	0.022UF 50V J
C1591	CCEA1HHR47T	CAP , ELECT	0.47UF 50V
C1592	HCQI1H682JZT	CAP , MYLAR	6800PF 50V J
C1595	CCEA1AH101T	CAP , ELECT	100UF 10V
C1600	CCEA1HH1R0T	CAP , ELECT	1UF 50V
C1604	CCEA1AH221T	CAP , ELECT	220UF 10V
C1605	CCEA1CH101T	CAP , ELECT	100UF 16V
C1614	CCEA1CH470T	CAP , ELECT	47UF 16V
C1616	CCEA1HH100T	CAP , ELECT	10UF 50V
C1617	CCEA1CH470T	CAP , ELECT	47UF 16V
C1620	CCEA1AH101T	CAP , ELECT	100UF 10V
C1621	CCEA1AH101T	CAP , ELECT	100UF 10V
C1624	CCEA1AH221T	CAP , ELECT	220UF 10V
C1625	CCEA1AH331T	CAP , ELECT	330UF 10V
C1626	CCEA1AH221T	CAP , ELECT	220UF 10V
C1627	CCEA1AH221T	CAP , ELECT	220UF 10V
C1628	CCEA1AH221T	CAP , ELECT	220UF 10V
C1629	CCEA1AH221T	CAP , ELECT	220UF 10V
C1651	CCEA1HH1R0T	CAP , ELECT	1UF 50V
C1652	CCEA1AH221T	CAP , ELECT	220UF 10V
C1653	CCEA1AH221T	CAP , ELECT	220UF 10V
C1654	CCEA1HH100T	CAP , ELECT	10UF 50V
C1655	CCEA1HH100T	CAP , ELECT	10UF 50V
C1657	CCEA1CH470T	CAP , ELECT	47UF 16V
C1658	CCEA1HH100T	CAP , ELECT	10UF 50V
C1659	CCEA1HH100T	CAP , ELECT	10UF 50V
C1661	CCEA1CH470T	CAP , ELECT	47UF 16V
C1662	CCEA1HH100T	CAP , ELECT	10UF 50V
C1663	CCEA1HH100T	CAP , ELECT	10UF 50V
C1665	CCEA1CH470T	CAP , ELECT	47UF 16V
C1666	CCEA1AH221T	CAP , ELECT	220UF 10V

Ref. Designator	Part Number	Description		Qty
VIDEO PCB ASS'Y		COP12045B		
C1667	CCEA1HH100T	CAP , ELECT	10UF 50V	1
<i>Semiconductors</i>				
D1501	CVDPG05GBUSCRTP	DIODE , ESD PROTECTION USC	PG05GBUSC-RTK/P , KEC	1
D1502	CVDPG05GBUSCRTP	DIODE , ESD PROTECTION USC	PG05GBUSC-RTK/P , KEC	1
D1503	CVDPG05GBUSCRTP	DIODE , ESD PROTECTION USC	PG05GBUSC-RTK/P , KEC	1
D1504	CVDPG05GBUSCRTP	DIODE , ESD PROTECTION USC	PG05GBUSC-RTK/P , KEC	1
D1505	CVDPG05GBUSCRTP	DIODE , ESD PROTECTION USC	PG05GBUSC-RTK/P , KEC	1
D1506	CVDPG05GBUSCRTP	DIODE , ESD PROTECTION USC	PG05GBUSC-RTK/P , KEC	1
D1507	CVDPG05GBUSCRTP	DIODE , ESD PROTECTION USC	PG05GBUSC-RTK/P , KEC	1
D1508	CVDPG05GBUSCRTP	DIODE , ESD PROTECTION USC	PG05GBUSC-RTK/P , KEC	1
D1509	CVDPG05GBUSCRTP	DIODE , ESD PROTECTION USC	PG05GBUSC-RTK/P , KEC	1
D1510	CVDPG05GBUSCRTP	DIODE , ESD PROTECTION USC	PG05GBUSC-RTK/P , KEC	1
D1511	HVD1SS355T	DIODE , CHIP	1SS355TE-17	1
D1512	HVD1SS355T	DIODE , CHIP	1SS355TE-17	1
D1513	HVD1SS355T	DIODE , CHIP	1SS355TE-17	1
D1514	HVD1SS355T	DIODE , CHIP	1SS355TE-17	1
IC1501	HVINJM2296M	I.C , VIDEO SW	NJM2296M	1
IC1502	HVINJM2296M	I.C , VIDEO SW	NJM2296M	1
IC1503	HVINJM2296M	I.C , VIDEO SW	NJM2296M	1
IC1504	HVINJM2296M	I.C , VIDEO SW	NJM2296M	1
IC1505	CVINJM2505AFTE1	I.C , VIDEO AMP(4.5~9.0V , 200MW , MTP5)	NJM2505AF-TE1 , JRC	1
IC1506	CVINJM2505AFTE1	I.C , VIDEO AMP(4.5~9.0V , 200MW , MTP5)	NJM2505AF-TE1 , JRC	1
IC1507	CVINJM2505AFTE1	I.C , VIDEO AMP(4.5~9.0V , 200MW , MTP5)	NJM2505AF-TE1 , JRC	1
IC1513	CVIBU4094BCF	I.C , 8-bit compatible shift / store register	BU4094BCF-E2	1
IC1514	CVIBU4094BCF	I.C , 8-bit compatible shift / store register	BU4094BCF-E2	1
IC1518	HVILC74763M	I.C , OSD	LC74763M-9602-E	1
IC1519	CVIMM1505XNRE	I.C , VIDEO SW(2IN-10UT, SOT-26)	MM1505XNRE , MITSUMI	1
IC1521	HVINJM2586AMTE1	I.C , VIDEO SW	NJM2586	1
Q1505	HVTKRA107S	TRANSISTOR , CHIP PNP	KRA107S-RTK/P	1
Q1506	HVTKRC107S	TRANSISTOR , CHIP NPN	KRC107S-RTK/P	1
Q1501	HVTKTC3199YT	TRANSISTOR NPN	KTC3199Y	1
Q1502	HVTKTC3199YT	TRANSISTOR NPN	KTC3199Y	1
Q1503	HVTKTA1267YT	TRANSISTOR PNP	KTA1267Y	1
Q1504	HVTKTA1267YT	TRANSISTOR PNP	KTA1267Y	1
IC1517	HVIKIA7806API	I.C , REGULATOR +6V	KIA7806API TO-220AB	1
<i>Resistors</i>				
R1500	CRJ10DF75R0T	RES , CHIP 1% 75 OHM	75 OHM, 1%	1
R1501	CRJ10DF75R0T	RES , CHIP 1% 75 OHM	75 OHM, 1%	1
R1502	CRJ10DF75R0T	RES , CHIP 1% 75 OHM	75 OHM, 1%	1
R1503	CRJ10DF75R0T	RES , CHIP 1% 75 OHM	75 OHM, 1%	1
R1504	CRJ10DF78R7T	RES , CHIP 78.7 OHM/1608/1%	78.7 ohm 1/16W 1% 0603	1
R1505	CRJ10DF75R0T	RES , CHIP 1% 75 OHM	75 OHM, 1%	1
R1506	CRJ10DF75R0T	RES , CHIP 1% 75 OHM	75 OHM, 1%	1
R1507	CRJ10DF75R0T	RES , CHIP 1% 75 OHM	75 OHM, 1%	1
R1508	CRJ10DF75R0T	RES , CHIP 1% 75 OHM	75 OHM, 1%	1
R1509	CRJ10DJ1R0T	RES , CHIP	1 ohm 1/16W 5% 0603	1
R1510	CRJ10DJ1R0T	RES , CHIP	1 ohm 1/16W 5% 0603	1
R1511	CRJ10DJ1R0T	RES , CHIP	1 ohm 1/16W 5% 0603	1
R1512	CRJ10DJ1R0T	RES , CHIP	1 ohm 1/16W 5% 0603	1
R1513	CRJ10DJ1R0T	RES , CHIP	1 ohm 1/16W 5% 0603	1
R1514	CRJ10DJ1R0T	RES , CHIP	1 ohm 1/16W 5% 0603	1
R1515	CRJ10DJ1R0T	RES , CHIP	1 ohm 1/16W 5% 0603	1
R1516	CRJ10DJ1R0T	RES , CHIP	1 ohm 1/16W 5% 0603	1
R1517	CRJ10DJ822T	RES , CHIP	8K2 ohm 1/16W 5% 0603	1
R1518	CRJ10DJ822T	RES , CHIP	8K2 ohm 1/16W 5% 0603	1
R1519	CRJ10DJ154T	RES , CHIP	150K ohm 1/16W 5% 0603	1
R1520	CRJ10DJ271T	RES , CHIP	270 ohm 1/16W 5% 0603	1
R1521	CRJ10DJ0R0T	RES , CHIP	0 ohm 1/16W 0% 0603	1
R1536	CRJ10DF75R0T	RES , CHIP 1% 75 OHM	75 ohm 1/16W 1% 0603	1
R1537	CRJ10DF75R0T	RES , CHIP 1% 75 OHM	75 ohm 1/16W 1% 0603	1
R1538	CRJ10DF75R0T	RES , CHIP 1% 75 OHM	75 ohm 1/16W 1% 0603	1
R1542	CRJ10DF75R0T	RES , CHIP 1% 75 OHM	75 ohm 1/16W 1% 0603	1
R1543	CRJ10DF75R0T	RES , CHIP 1% 75 OHM	75 ohm 1/16W 1% 0603	1
R1544	CRJ10DF75R0T	RES , CHIP 1% 75 OHM	75 ohm 1/16W 1% 0603	1
R1545	CRJ10DJ103T	RES , CHIP	10K ohm 1/16W 5% 0603	1
R1546	CRJ10DJ103T	RES , CHIP	10K ohm 1/16W 5% 0603	1
R1547	CRJ10DJ103T	RES , CHIP	10K ohm 1/16W 5% 0603	1

Ref. Designator	Part Number	Description		Qty
VIDEO PCB ASS'Y		COP12045B		
R1549	CRJ10DF75R0T	RES, CHIP 1% 75 OHM	75 ohm 1/16W 1% 0603	1
R1551	CRJ10DF78R7T	RES, CHIP 78.7 OHM/1608/1%	78.7 ohm 1/16W 1% 0603	1
R1552	CRJ10DF75R0T	RES, CHIP 1% 75 OHM	75 ohm 1/16W 1% 0603	1
R1553	CRJ10DF78R7T	RES, CHIP 78.7 OHM/1608/1%	78.7 ohm 1/16W 1% 0603	1
R1554	CRJ10DF78R7T	RES, CHIP 78.7 OHM/1608/1%	78.7 ohm 1/16W 1% 0603	1
R1555	CRJ10DF78R7T	RES, CHIP 78.7 OHM/1608/1%	78.7 ohm 1/16W 1% 0603	1
R1556	CRJ10DJ103T	RES, CHIP	10K ohm 1/16W 5% 0603	1
R1557	CRJ10DJ103T	RES, CHIP	10K ohm 1/16W 5% 0603	1
R1558	CRJ10DJ103T	RES, CHIP	10K ohm 1/16W 5% 0603	1
R1559	CRJ10DJ680T	RES, CHIP	68 ohm 1/16W 5% 0603	1
R1560	CRJ10DJ2R7T	RES, CHIP	2R7 ohm 1/16W 5% 0603	1
R1561	CRJ10DJ103T	RES, CHIP	10K ohm 1/16W 5% 0603	1
R1562	CRJ10DJ121T	RES, CHIP	120 ohm 1/16W 5% 0603	1
R1563	CRJ10DJ121T	RES, CHIP	120 ohm 1/16W 5% 0603	1
R1564	CRJ10DJ102T	RES, CHIP	1K ohm 1/16W 5% 0603	1
R1565	CRJ10DJ682T	RES, CHIP	6K8 ohm 1/16W 5% 0603	1
R1566	CRJ10DJ152T	RES, CHIP	1K5 ohm 1/16W 5% 0603	1
R1567	CRJ10DJ103T	RES, CHIP	10K ohm 1/16W 5% 0603	1
R1568	CRJ10DJ224T	RES, CHIP	220K ohm 1/16W 5% 0603	1
R1569	CRJ10DJ124T	RES, CHIP	120K ohm 1/16W 5% 0603	1
R1570	CRJ10DJ121T	RES, CHIP	120 ohm 1/16W 5% 0603	1
R1571	CRJ10DJ105T	RES, CHIP	1M ohm 1/16W 5% 0603	1
R1572	CRJ10DJ105T	RES, CHIP	1M ohm 1/16W 5% 0603	1
R1577	CRJ10DJ102T	RES, CHIP	1K ohm 1/16W 5% 0603	1
R1578	CRJ10DJ102T	RES, CHIP	1K ohm 1/16W 5% 0603	1
R1579	CRJ10DJ102T	RES, CHIP	1K ohm 1/16W 5% 0603	1
R1580	CRJ10DJ103T	RES, CHIP	10K ohm 1/16W 5% 0603	1
R1581	CRJ10DJ392T	RES, CHIP	3K9 ohm 1/16W 5% 0603	1
R1584	CRJ10DJ333T	RES, CHIP	33K ohm 1/16W 5% 0603	1
R1585	CRJ10DJ222T	RES, CHIP	2K2 ohm 1/16W 5% 0603	1
R1586	CRJ10DJ680T	RES, CHIP	68 ohm 1/16W 5% 0603	1
R1587	CRJ10DJ682T	RES, CHIP	6K8 ohm 1/16W 5% 0603	1
R1588	CRJ10DJ103T	RES, CHIP	10K ohm 1/16W 5% 0603	1
R1591	CRJ10DJ102T	RES, CHIP	1K ohm 1/16W 5% 0603	1
R1592	CRJ10DJ102T	RES, CHIP	1K ohm 1/16W 5% 0603	1
R1593	CRJ10DJ102T	RES, CHIP	1K ohm 1/16W 5% 0603	1
R1594	CRJ10DJ123T	RES, CHIP	12K ohm 1/16W 5% 0603	1
R1595	CRJ10DJ102T	RES, CHIP	1K ohm 1/16W 5% 0603	1
R1596	CRJ10DJ102T	RES, CHIP	1K ohm 1/16W 5% 0603	1
R1597	CRJ10DJ102T	RES, CHIP	1K ohm 1/16W 5% 0603	1
R1600	CRJ10DJ123T	RES, CHIP	12K ohm 1/16W 5% 0603	1
R1602	CRJ10DF75R0T	RES, CHIP 1% 75 OHM	75 ohm 1/16W 1% 0603	1
R1603	CRJ10DF75R0T	RES, CHIP 1% 75 OHM	75 ohm 1/16W 1% 0603	1
R1604	CRJ10DF75R0T	RES, CHIP 1% 75 OHM	75 ohm 1/16W 1% 0603	1
R1605	CRJ10DF75R0T	RES, CHIP 1% 75 OHM	75 ohm 1/16W 1% 0603	1
R1606	CRJ10DF75R0T	RES, CHIP 1% 75 OHM	75 ohm 1/16W 1% 0603	1
R1607	CRJ10DF75R0T	RES, CHIP 1% 75 OHM	75 ohm 1/16W 1% 0603	1
R1608	CRJ10DF75R0T	RES, CHIP 1% 75 OHM	75 ohm 1/16W 1% 0603	1
R1609	CRJ10DF75R0T	RES, CHIP 1% 75 OHM	75 ohm 1/16W 1% 0603	1
R1610	CRJ10DF75R0T	RES, CHIP 1% 75 OHM	75 ohm 1/16W 1% 0603	1
R1618	CRJ10DF75R0T	RES, CHIP 1% 75 OHM	75 ohm 1/16W 1% 0603	1
R1619	CRJ10DF75R0T	RES, CHIP 1% 75 OHM	75 ohm 1/16W 1% 0603	1
R1620	CRJ10DF75R0T	RES, CHIP 1% 75 OHM	75 ohm 1/16W 1% 0603	1
R1621	CRJ10DF75R0T	RES, CHIP 1% 75 OHM	75 ohm 1/16W 1% 0603	1
R1622	CRJ10DF75R0T	RES, CHIP 1% 75 OHM	75 ohm 1/16W 1% 0603	1
R1623	CRJ10DF75R0T	RES, CHIP 1% 75 OHM	75 ohm 1/16W 1% 0603	1
R1632	CRJ10DJ102T	RES, CHIP	1K ohm 1/16W 5% 0603	1
R1633	CRJ10DJ101T	RES, CHIP	100 ohm 1/16W 5% 0603	1
R1635	CRJ10DJ750T	RES, CHIP	75 ohm 1/16W 5% 0603	1
R1636	CRJ10DJ101T	RES, CHIP	100 ohm 1/16W 5% 0603	1
R1637	CRJ10DJ101T	RES, CHIP	100 ohm 1/16W 5% 0603	1
R1638	CRJ10DJ750T	RES, CHIP	75 ohm 1/16W 5% 0603	1
R1639	CRJ10DJ101T	RES, CHIP	100 ohm 1/16W 5% 0603	1
R1640	CRJ10DJ101T	RES, CHIP	100 ohm 1/16W 5% 0603	1
R1641	CRJ10DJ750T	RES, CHIP	75 ohm 1/16W 5% 0603	1
R1642	CRJ10DJ101T	RES, CHIP	100 ohm 1/16W 5% 0603	1
R1643	CRJ10DJ101T	RES, CHIP	100 ohm 1/16W 5% 0603	1
<i>Miscellaneous</i>				
L1502	CLQ03D470JT	COIL, RADIAL (47UH, 5%, 2.7 OHM, 192mA, 5.0MM)	EL0606RA-470J-PF, TDK	1

Ref. Designator	Part Number	Description		Qty
VIDEO PCB ASS'Y		COP12045B		
L1503	KLQ5R6J405T	COIL, PEAKING(RADIAL)	5.6UH J 4X5	1
L1504	CLQ03D470JT	COIL , RADIAL (47UH, 5%, 2.7 OHM, 192mA, 5.0MM)	EL0606RA-470J-PF , TDK	1
L1505	CLQ03D470JT	COIL , RADIAL (47UH, 5%, 2.7 OHM, 192mA, 5.0MM)	EL0606RA-470J-PF , TDK	1
L1506	CLQ03D470JT	COIL , RADIAL (47UH, 5%, 2.7 OHM, 192mA, 5.0MM)	EL0606RA-470J-PF , TDK	1
L1507	CLQ03D470JT	COIL , RADIAL (47UH, 5%, 2.7 OHM, 192mA, 5.0MM)	EL0606RA-470J-PF , TDK	1
JA1500	CJJ9R002Z	JACK , RCA/DIN (3P, 304A, YLx3, S-VHSx3, AU PL)	RCA/DIN-304AGGG-01	1
JA1501	CJJ9P004Z	JACK , RCA/DIN (2P, 220A, YLx2, S-VHSx2, AU PL)	RCA/DIN-220AGGG-01	1
JA1502	CJJ4M063Z	JACK , RCA/DIN (1P, R102D04, YL, AU PL)	R102-D04AGG(VI)-01	1
JA1503	CJJ4R036Y	JACK , RCA (6P, 610A, RD BL GN x 2, AU PL)	RCA-610AG-00-32G	1
JA1504	CJJ4R036Y	JACK , RCA (6P, 610A, RD BL GN x 2, AU PL)	RCA-610AG-00-32G	1
K1500	CSL4C010ZE	RELAY , D3009(1-1462033-4) ,TYCO	D3009(1-1462033-4)	1
K1501	CSL4C010ZE	RELAY , D3009(1-1462033-4) ,TYCO	D3009(1-1462033-4)	1
N1504	CWBAVR755N1504	6P WIRE ASS'Y(500MM, 2.0MM)		1
P1500	CJP05GB48ZW	WAFER	GIL-S-05P-S2L2-EF 5P	1
X1501	HOX14318E220C	CRYSTAL	14.31818MHz HC-49/S WOOIN	1
X1502	HOX17734E220C	CRYSTAL	17.734475MHz HC-49/S WOOIN	1
BD1501	CLZ9R010Z	BEAD , FERRITE (FCM2012KF-121T08 , 120 OHM)	FCM2012KF-121T08 120ohm 2012	1
BD1502	CLZ9R010Z	BEAD , FERRITE (FCM2012KF-121T08 , 120 OHM)	FCM2012KF-121T08 120ohm 2012	1
BD1503	CLZ9R010Z	BEAD , FERRITE (FCM2012KF-121T08 , 120 OHM)	FCM2012KF-121T08 120ohm 2012	1
BD1504	CLZ9R010Z	BEAD , FERRITE (FCM2012KF-121T08 , 120 OHM)	FCM2012KF-121T08 120ohm 2012	1
P1501	CJP40GA226ZB	FAM2501-4001A01BAB 2.54MM 40P	FAH250	1
SUB PCB ASS'Y		COP12050B		
				1
C5501	KCME2E104JP04T	CAP , METALLIZED FILM	100NF 250V 20% CPM	1
C5502	KCME2E104JP04T	CAP , METALLIZED FILM	100NF 250V 20% CPM	1
C5503	KCME2E104JP04T	CAP , METALLIZED FILM	100NF 250V 20% CPM	1
C5510	HCQ11H473JZT	CAP , MYLAR	0.047UF 50V J	1
C5511	HCQ11H473JZT	CAP , MYLAR	0.047UF 50V J	1
C5512	HCQ11H473JZT	CAP , MYLAR	0.047UF 50V J	1
F5501	CBA2D4000A2EYT	FUSE (LITTLE FUSE 382 SERIES) 4A 250V	4A 250V	1
F5502	CBA2D4000A2EYT	FUSE (LITTLE FUSE 382 SERIES) 4A 250V	4A 250V	1
D5500	CVDRS1004	DIODE , BRIDGE(RS-10)	RS1004 RS-10	1
D5502	CVDKBU6GMFRS6	DIODE , BRIDGE(RS-6 KINK TYPE)	KBU6GMFRS6 , DELTA	1
N4008	CWB1B003100GN	3P WIRE ASS'Y(100MM, 2.0MM)		1
N5501	CWBAVR755N5501	WIRE , ASS'Y		1
N5503	CJP04GB99ZM	WAFER	35237-0410 2.0mm 4P WHT	1
N5504	CJP04GB99ZM	WAFER	35237-0410 2.0mm 4P WHT	1
N5505	CJP04GB99ZM	WAFER	35237-0410 2.0mm 4P WHT	1
N5506	CJP04GB99ZM	WAFER	35237-0410 2.0mm 4P WHT	1
N5507	CJP07GB99ZY	HOUSING	35237-0710 2.0mm 7P WHT	1
P5001	CJP03GA90ZY	WAFER	35313-0310 3.96mm 3P	1
P5002	CJP03GA90ZY	WAFER	35313-0310 3.96mm 3P	1
P5502	CJP02KA060ZY	WAFER	YW396-03V 7.92mm 2P	1
P5503	CJP04GA98ZM	WAFER	35336-0410 2.0mm 4P WHT	1
P5504	CJP04GA98ZM	WAFER	35336-0410 2.0mm 4P WHT	1
P5505	CJP04GA98ZM	WAFER	35336-0410 2.0mm 4P WHT	1
P5506	CJP04GA98ZM	WAFER	35336-0410 2.0mm 4P WHT	1
P5507	CJP07GA98ZY	WAFER	35336-0710 2.0mm 7P WHT	1
Q4011	CVILM19CI22.4V	I.C , TEMP SENSOR	LM19CI22.4V , NATIONAL(T I)	1
Miscellaneous/Mechanical				
	CGK1A131C66	KNOB , COVER		1
	CGL1A222	INDICATOR , VOLUME		1
	CGU1A318Y	ORNAMENT , VOLUME		1
	CMH1A214	HOLDER , VOLUME		1
	CTB3+10JFZR	SCREW		6
	CTB4+6FFZR	SCREW		8
	CTW3+8JR	SCREW		10
	CKC1A184S60	COVER , TOP		1
	CHE154	CLAMPER , ARM		.12
	CDF1A021	STAND OFF(HEX M4X61.5H)		3
	CDF1A022	STAND OFF(HEX M4X87.4H)		1
	CDF1A023	STAND OFF(HEX M4X0.7 6X31.9H)		2
	CFNCF12310NXS	MOTOR , FAN(30X30X10MM,12V 5000RPM 100MM)	CF-12310N	1
	CFNCF12925HS	MOTOR , FAN(92X92X25MM,12V 2500RPM 300MM)	CF-12925HS35SB , COLORFUL	1
	CHD1A023R	SCREW , SPECIAL		4
	CHD1A036R	SCREW , SPECIAL		4
	CHD1A065R	SCREW , FLAT(2.6X4)		2

Ref. Designator	Part Number	Description		Qty
Miscellaneous/Mechanical				
	CHG1A373	CUSHION , FOOT AVR350		4
	CHG1A387	SPONGE(30X30X10T)		3
	CHG1A392	CUSHION , PEF		1
	CHG1A407	RUBBER , CUSHION		2
	CHG1A444	CUSHION , DISP		2
	CHG1A445	CUSHION , BOTTOM		4
	CHR301	CLAMPER		40
	CKF1A381Z	PANEL , REAR		1
	CKL1A100	FOOT , R		3
	CKL1A101	FOOT , L		1
	CLT5W031ZU	TRANS , MAIN POWER (UL, 120V 60Hz)	111X90 , SEO KYUNG	1
	CLZ9Z070Z	FERRITE , CORE		1
	CMC1A339	SHIELD , DIGITAL		2
	CMC1A357	SHIELD , FORM 0HD		1
	CMC1A358	SHIELD , FORM 0HD		5
	CMD1A645	BRACKET , ETHER		1
	CMD1A649	CHASSIS , FRONT		1
	CMD1A650	BRACKET , TRANS BOTTOM		1
	CMD1A651	BRACKET , FRAME GUIDE		1
	CMD1A652Z	BRACKET , FAN FRONT		1
	CMD1A653Z	BRACKET , FAN REAR		1
	CMD1A654	COVER , BOTTOM		1
	CMD1A656	BRACKET , AC INLET		2
	CMD1A658	BRACKET , FRAME GUIDE		1
	CMD1A659	BRACKET , VIDEO		1
	CNE1A011	NUT , M4 HEXAGON CIRCULAR EX		4
	CTB3.5+8JR	SCREW		4
	CTB3+10JFZR	SCREW		31
	CTB3+6FFZR	SCREW		17
	CTB3+6JFZR	SCREW		7
	CTB3+8JFZR	SCREW		10
	CTB3+8JFZR	SCREW		14
	CTB4+6FFZR	SCREW		9
	CTS3+8JFZR	SCREW		8
	CTW3+6JR	SCREW		5
	CTW3+8JFZR	SCREW		6
	CUA1A283	CHASSIS , MAIN AVR755		1
	CWB1B004150GG	4P WIRE ASS'Y(150MM, 2.0MM)		1
	CWB1B009200GG	9P WIRE ASS'Y(200MM, 2.0MM)		1
	CWC4C4A11B060A08BK	CABLE , CARD		1
	CWC4C4A11B080ABK	CABLE , CARD (11PIN, 80MM, 1.25MM, BLACK)		1
	CWC4C4A17B080ABK	CABLE , CARD (17PIN, 80MM, 1.25MM, BLACK)		1
	CWC4C4A29B180ABK	CABLE , CARD (29PIN, 180MM, 1.25MM, BLACK)		1
F3001	KBA2F1202TLUY	FUSE (326SERIES 326012,12A 250V 31.8mm SB)		1
F3101	KBA2C3150TLUY	FUSE (239SERIES 2393.15P, 3.15A 250V 20mm TL)		1
N3204	CWBAVR755N3204	5P WIRE ASS'Y(250MM, 2.0MM)		1
TUNER MODULE	CNVMB011MW0-81	TUNER MODULE USA ONLY	KST-MB011MW0-81 , KWANGSUNG	1

mm0.032

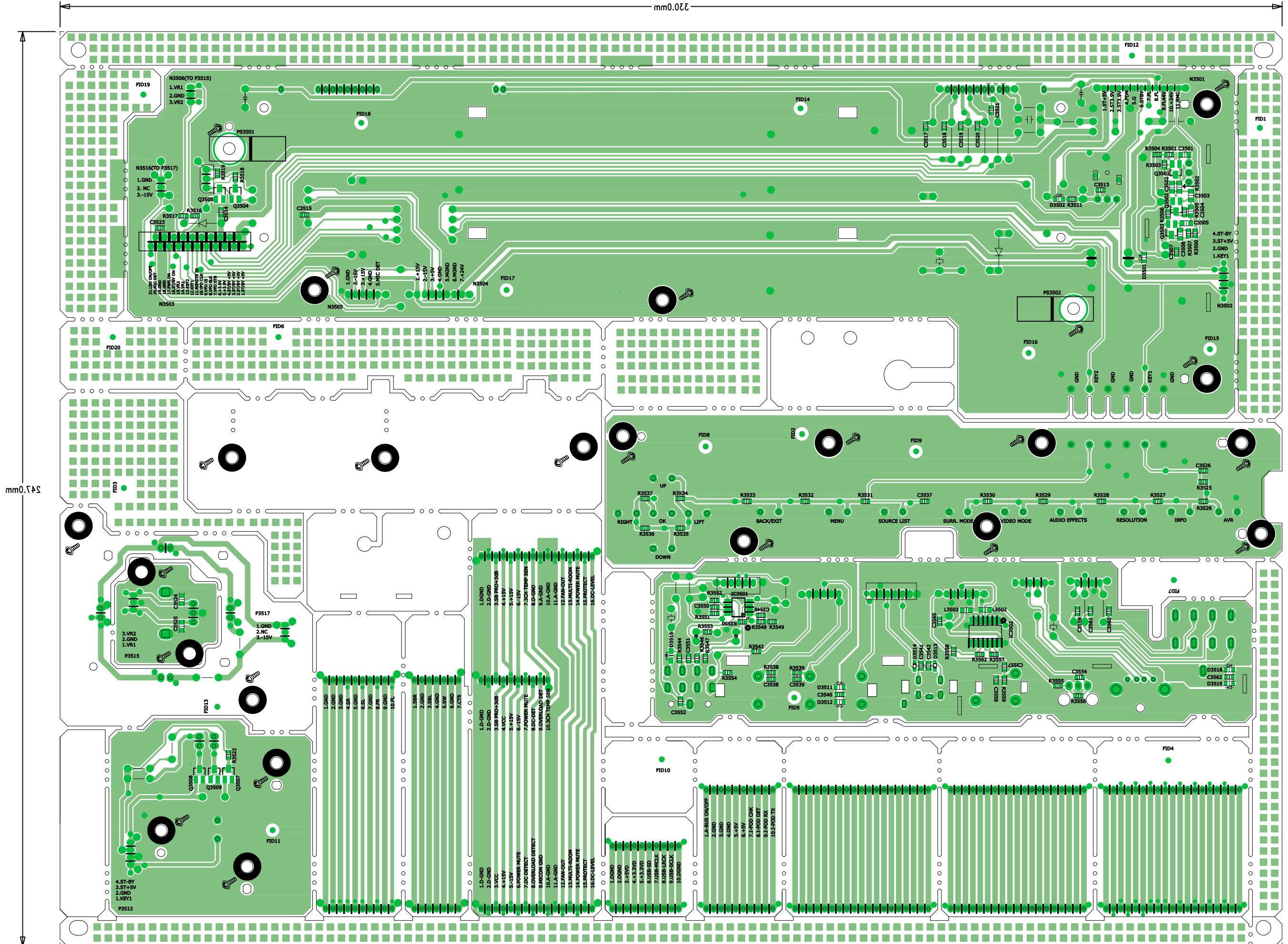

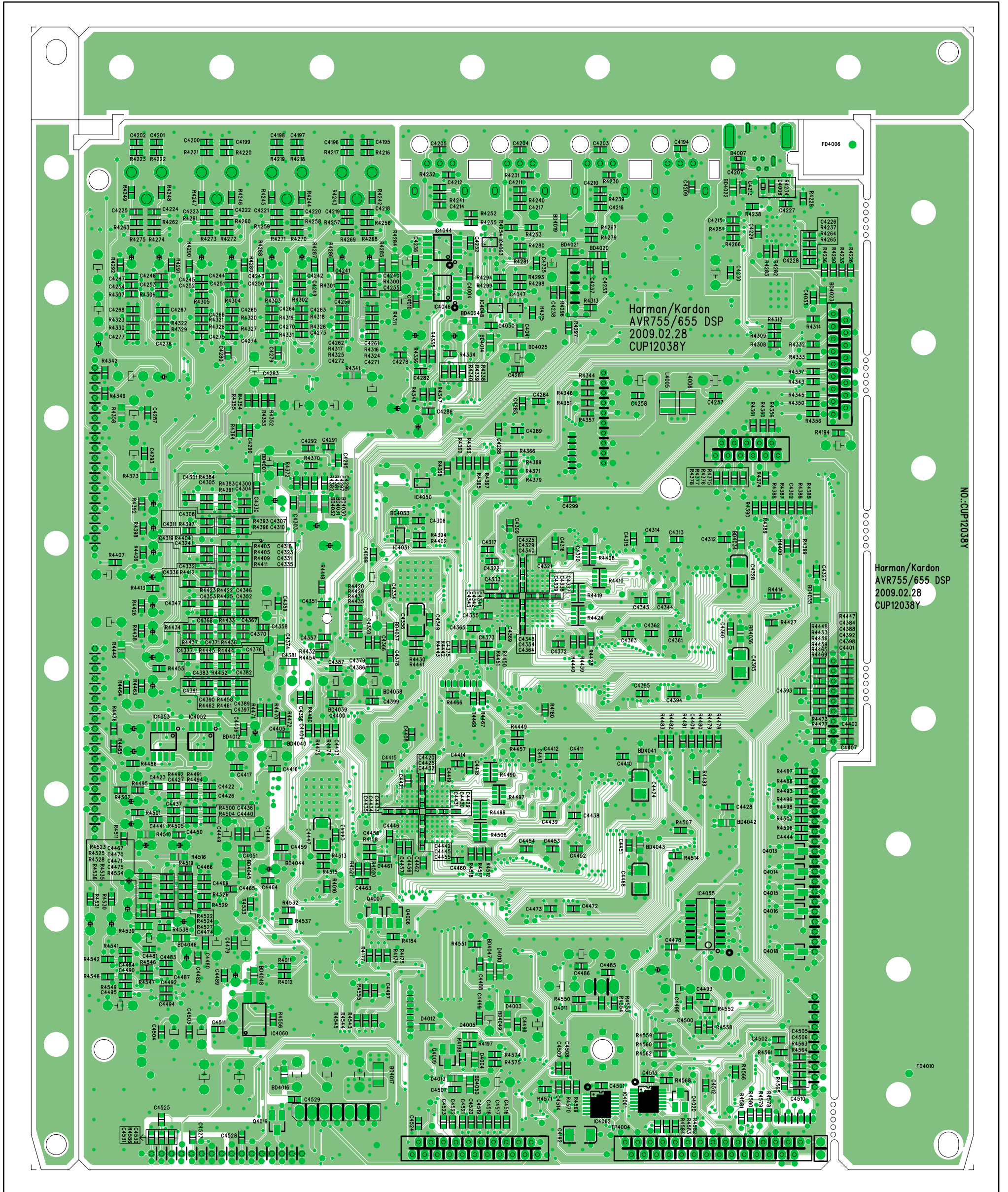

Harman/Kardon
AVR755/655 DSP
2009.02.28
CUP12038Y

NO: CUP12038Y

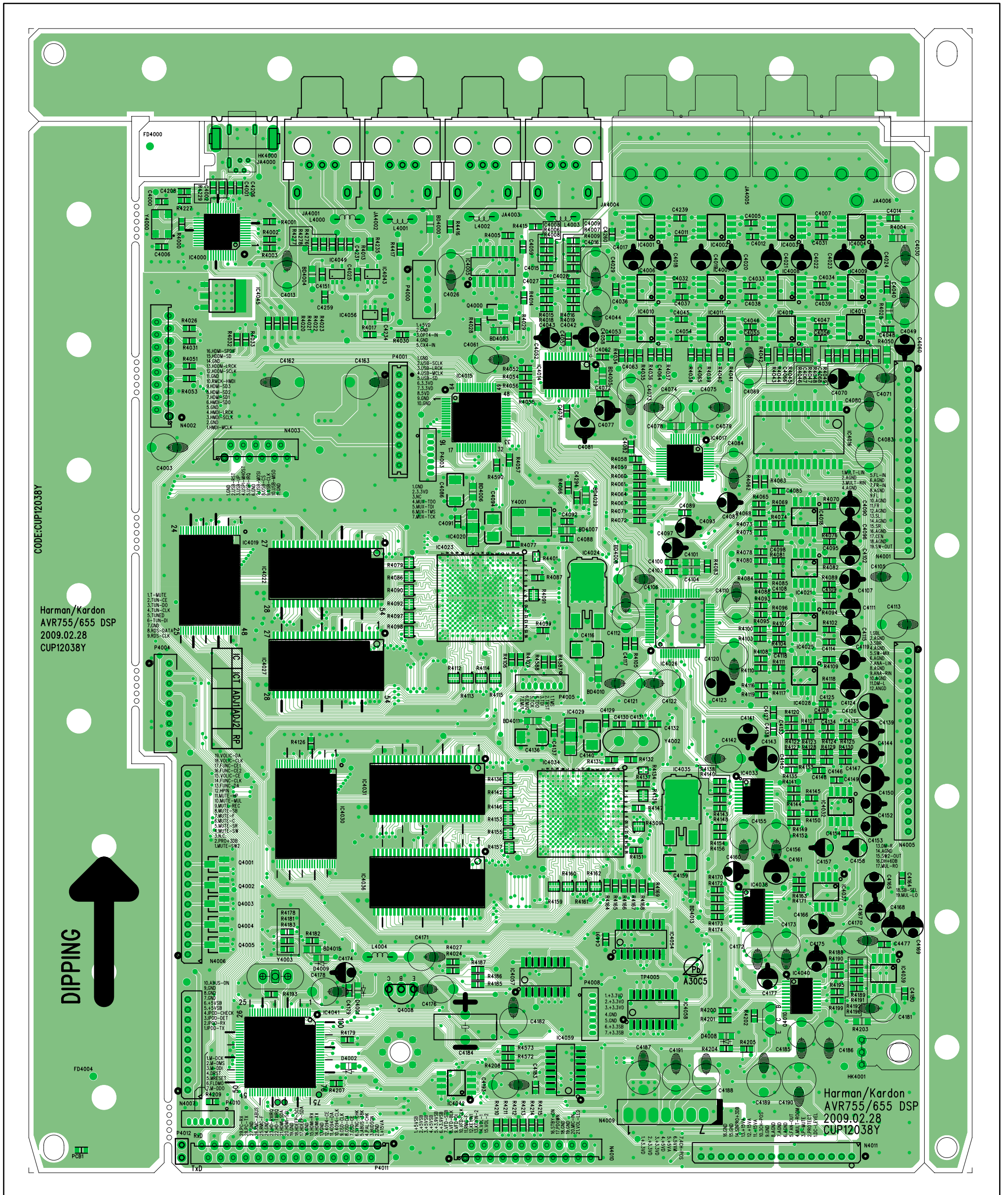

CODE: CUP12038Y

Harman/Kardon
AVR755/655 DSP
2009.02.28
CUP12038Y



Harman/Kardon
AVR755/655 DSP
2009.02.28
CUP12038Y

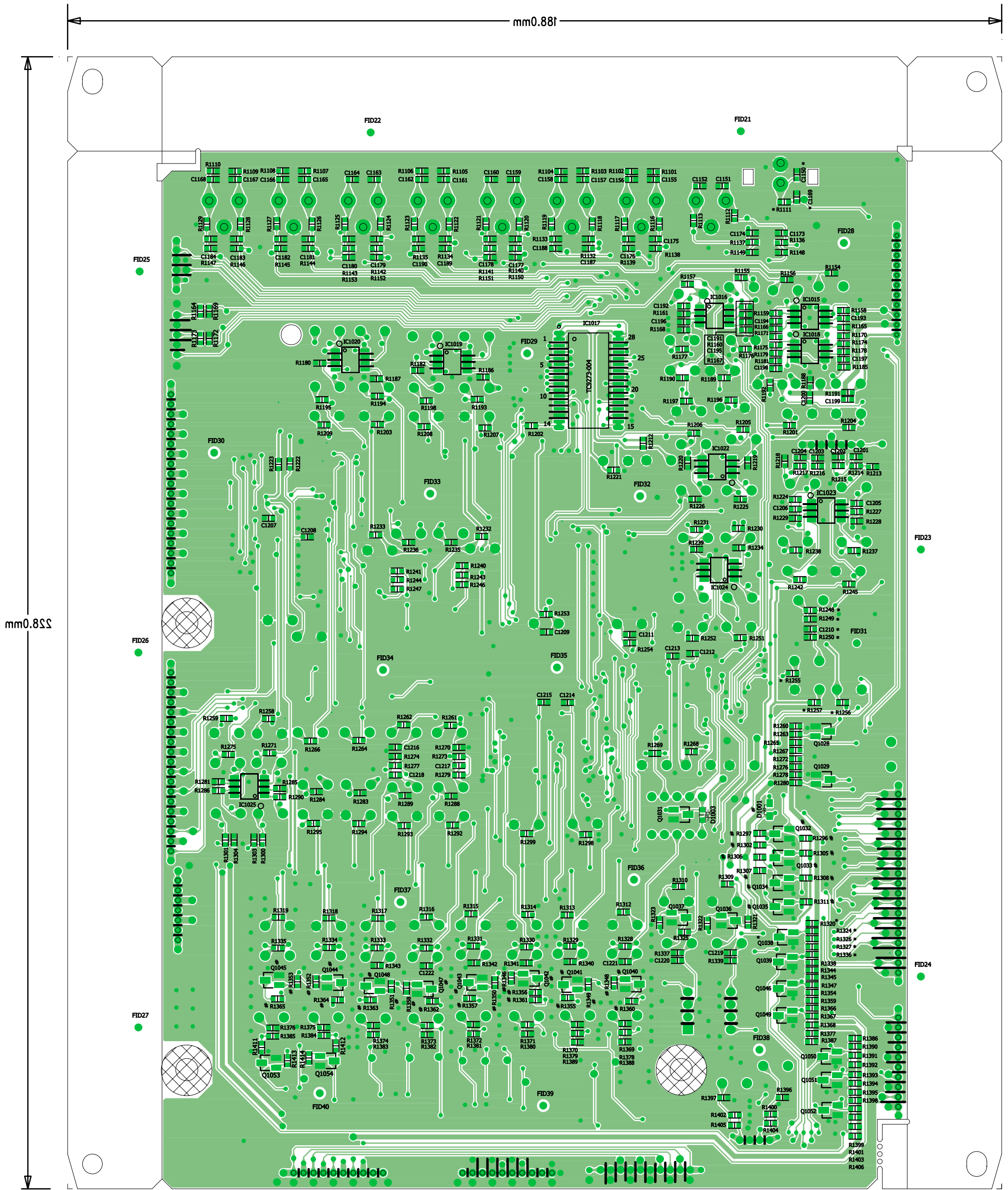

188.0mm

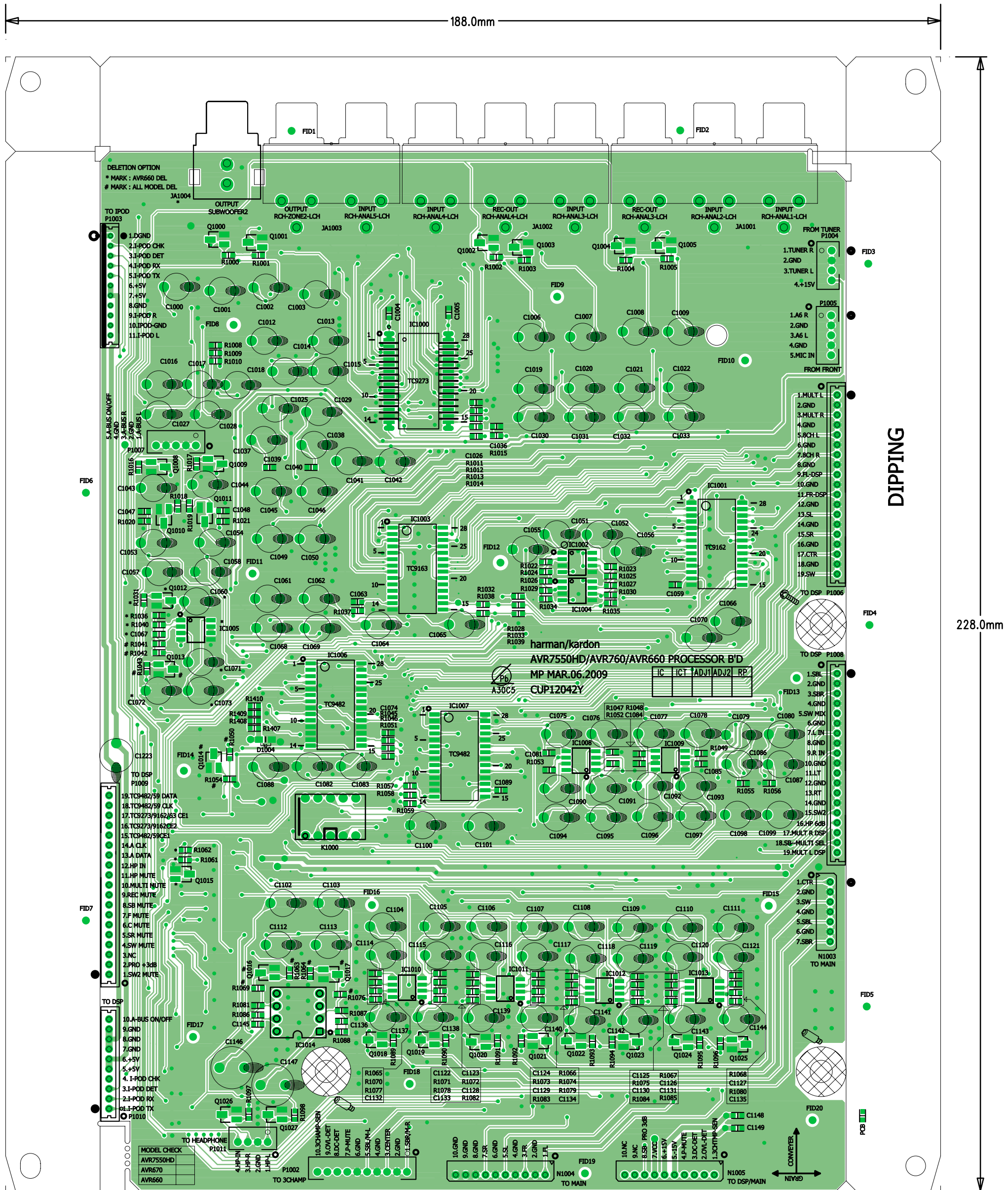

228.0mm

DIPPING



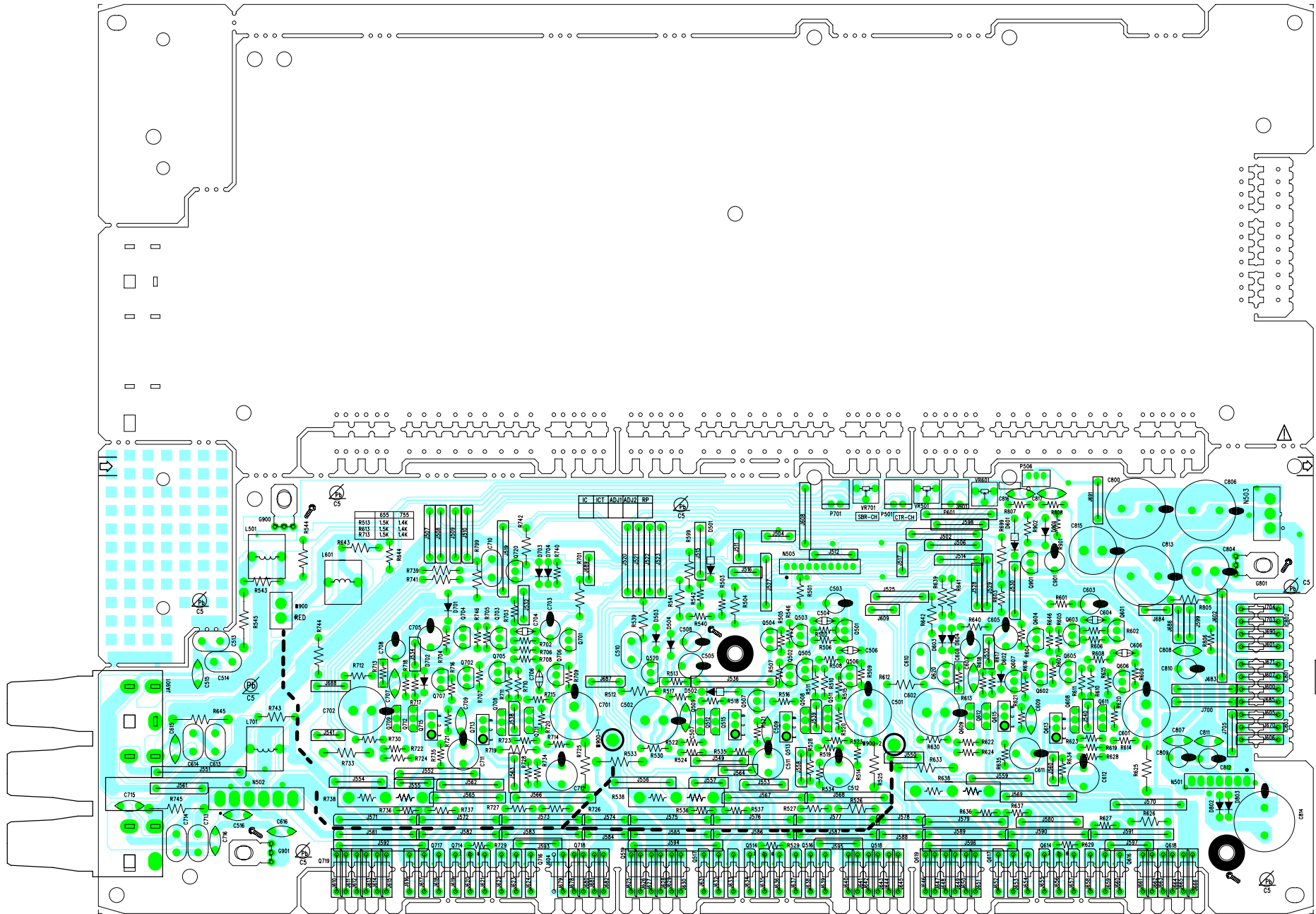

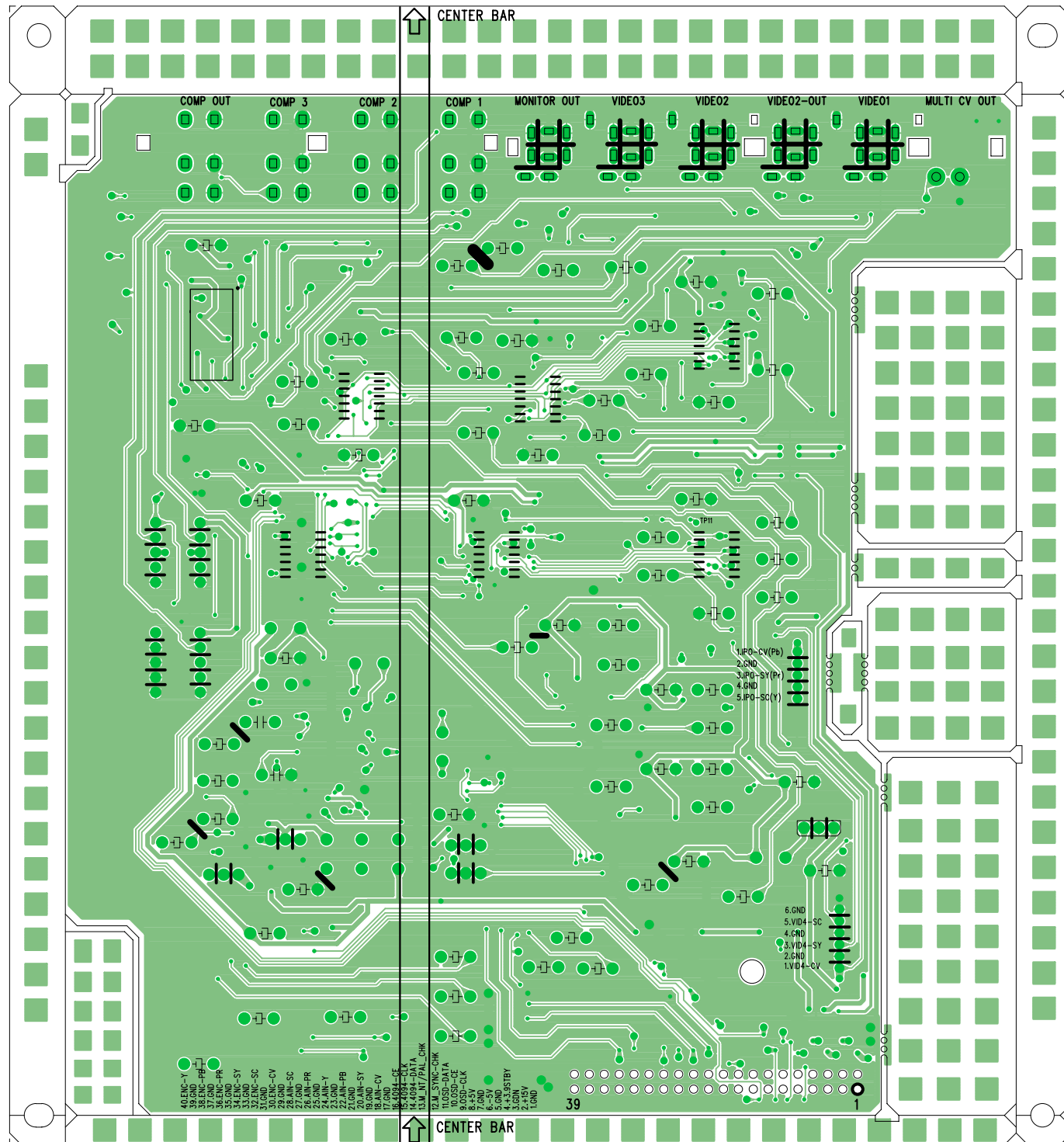

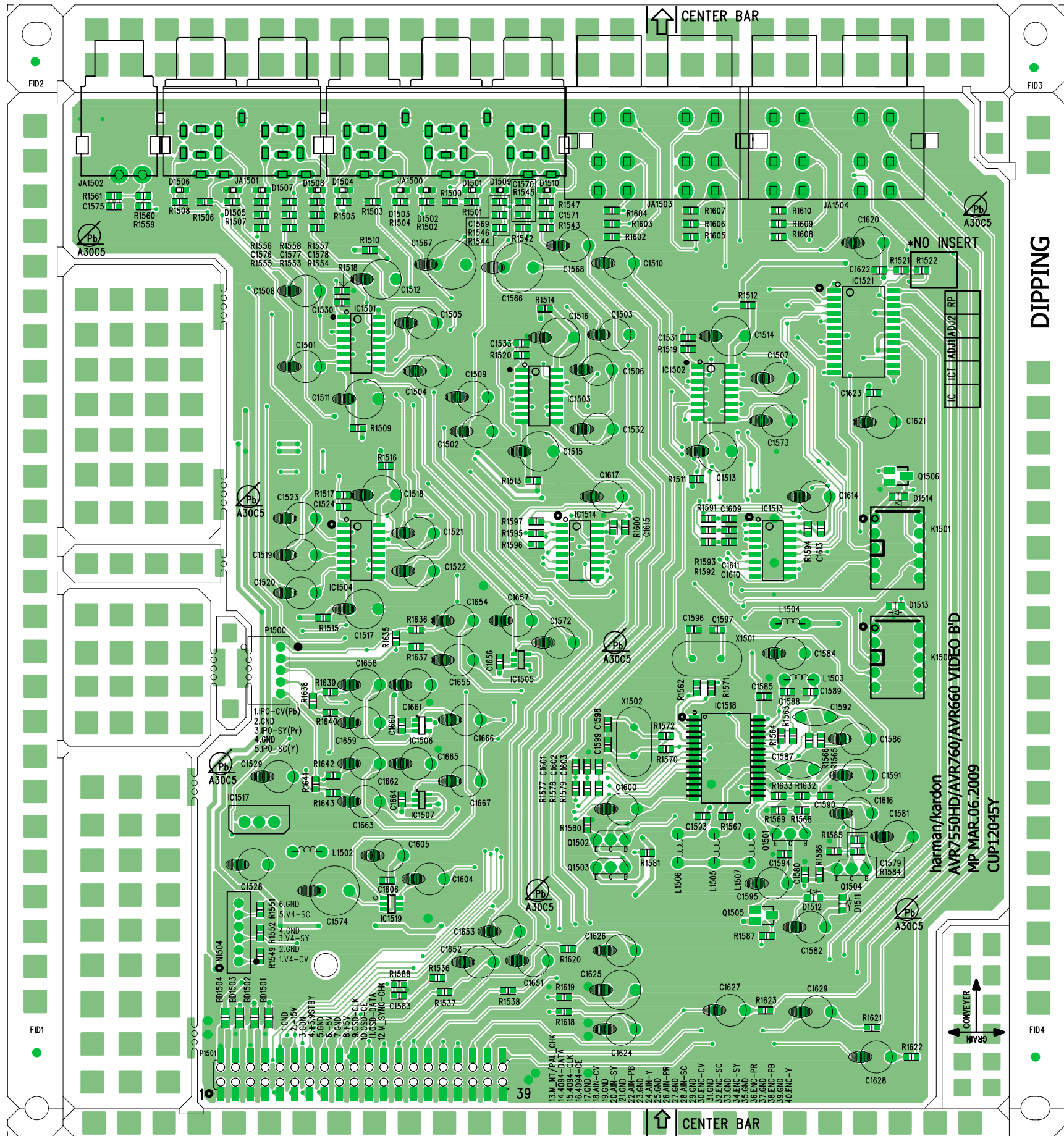

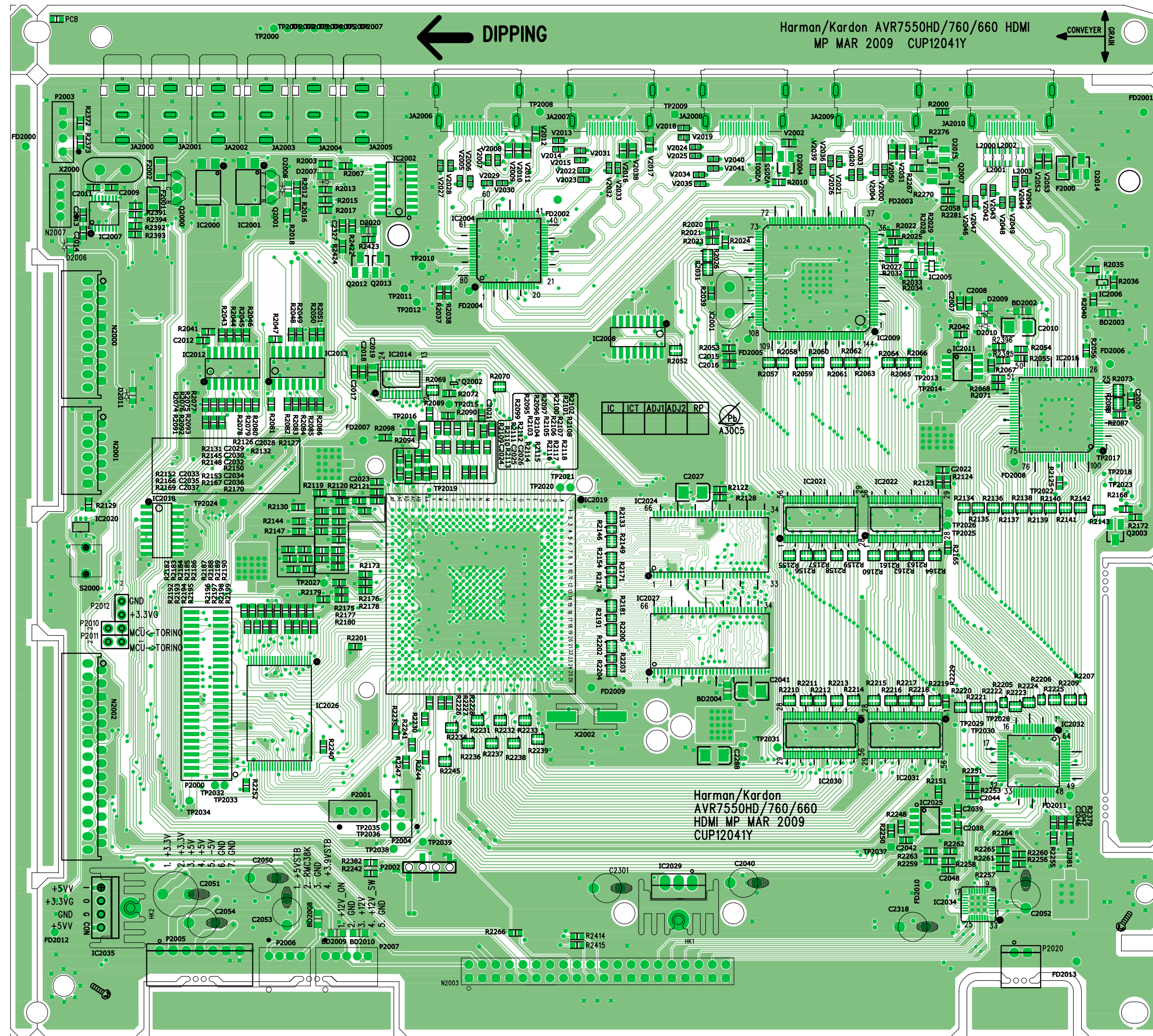

330.0mm

247.0mm

Harman/Kardon
AVR7550/AVR760/AVR660 MAIN B'D
MAR.24.2009.
CUP12037Y

Suggestion: Modify PCB
tooling to make this area
flat to prevent soldering
open

DIPPING ←

DANECH

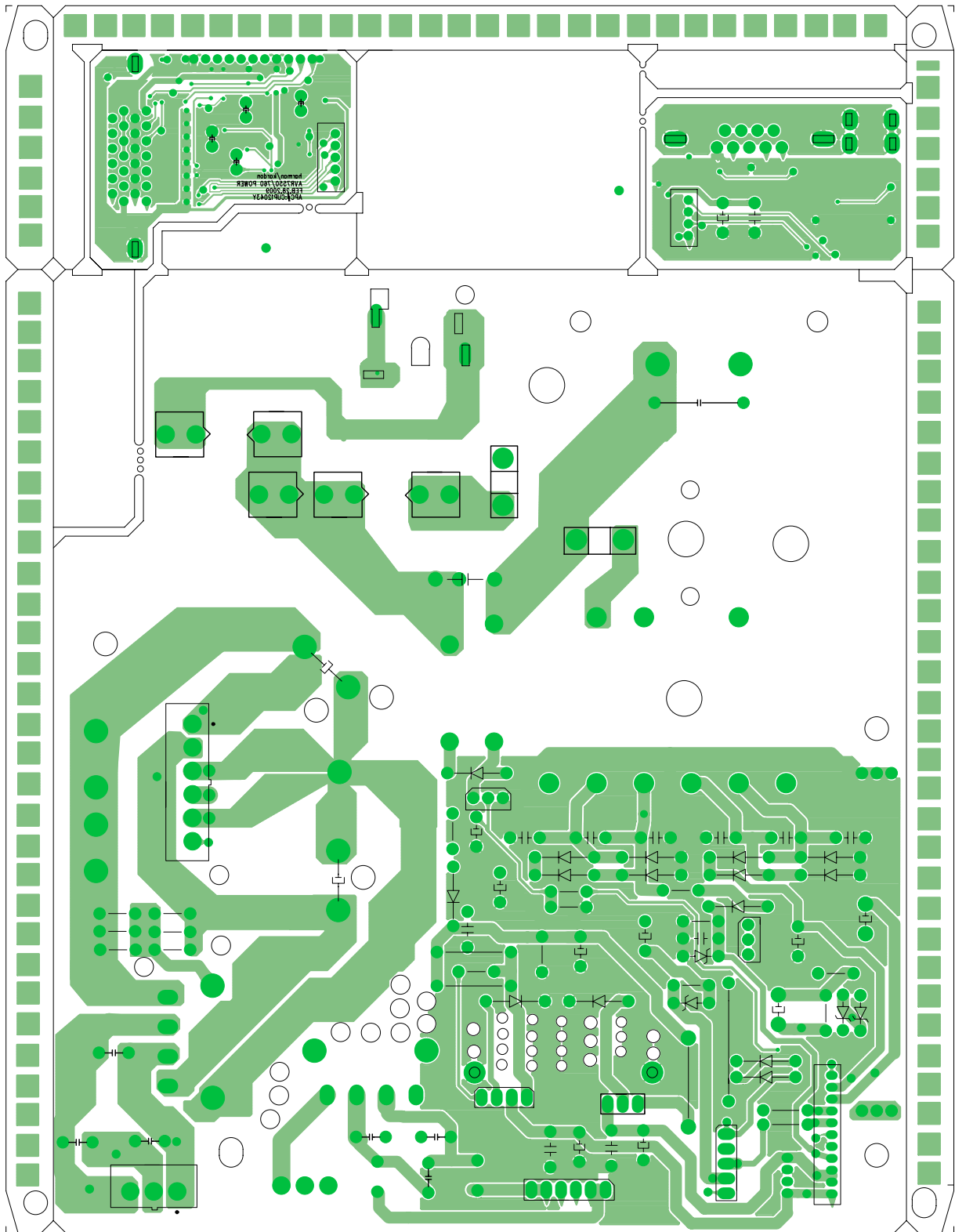

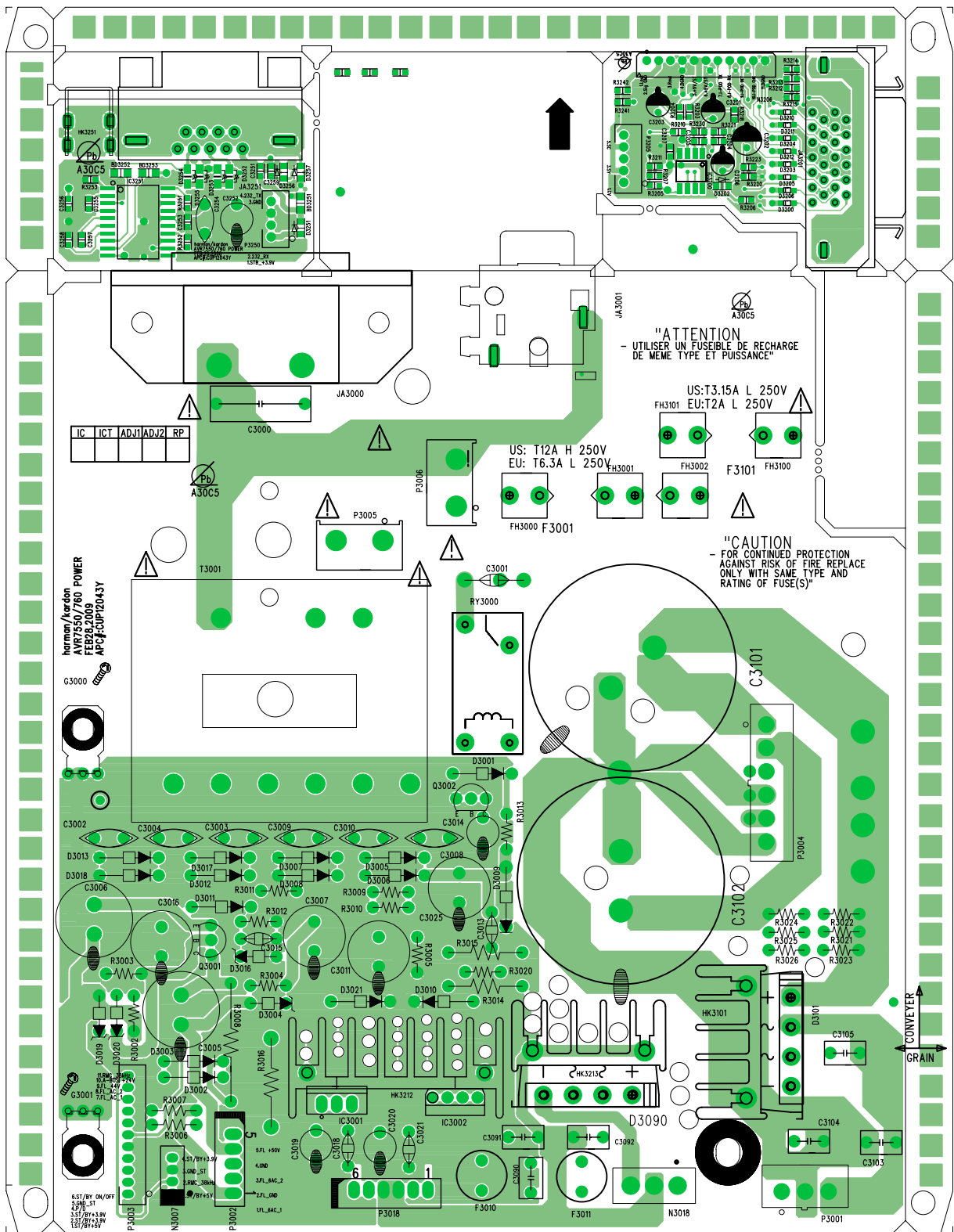

Semiconductor pinout drawings

•IC

1. A3S56D40ETP (HDMI: IC2024, IC2025)

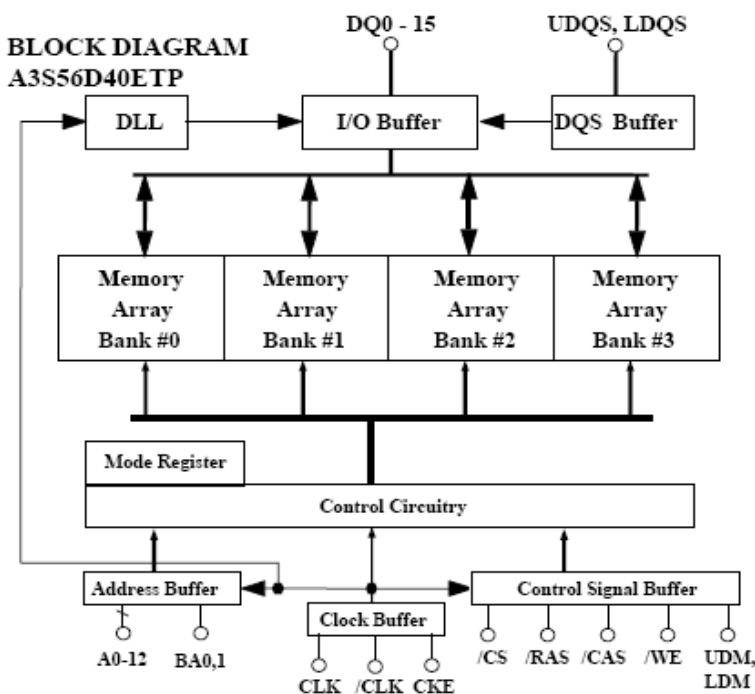

2. 74FCT38072DCG(HDMI IC2010)

FUNCTIONAL BLOCK DIAGRAM

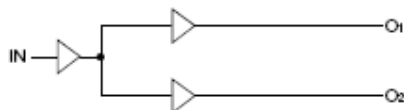

PIN CONFIGURATION

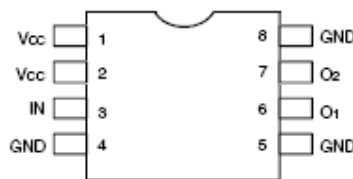

SOIC
TOP VIEW

TEST CONDITIONS

Symbol	Vcc = 3.3V ±0.3V	Unit
CL	15	pF
RL	33	Ω
RT	Zout of pulse generator	Ω
tr / tf	1 (0V to 3V or 3V to 0V)	ns

DEFINITIONS:

CL = Load capacitance: includes jig and probe capacitance.
 RT = Termination resistance: should be equal to Zout of the Pulse Generator.
 tr / tf = Rise/Fall time of the input stimulus from the Pulse Generator.

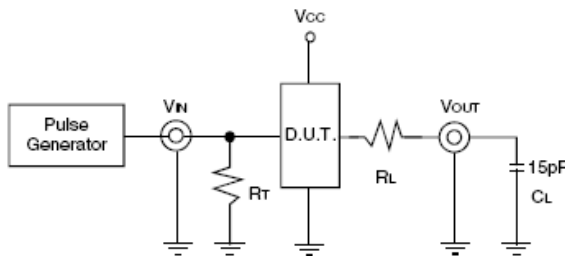

CL = 15pF Circuit

3. DAD1580BRT(HDMI IC2039)

PIN CONFIGURATIONS

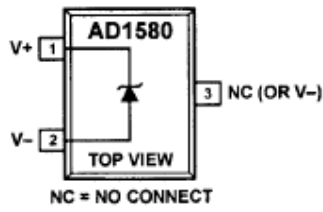

Figure 1.

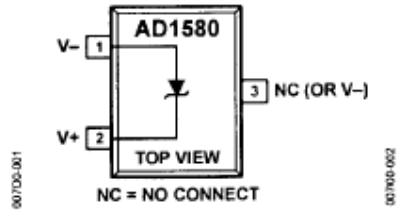
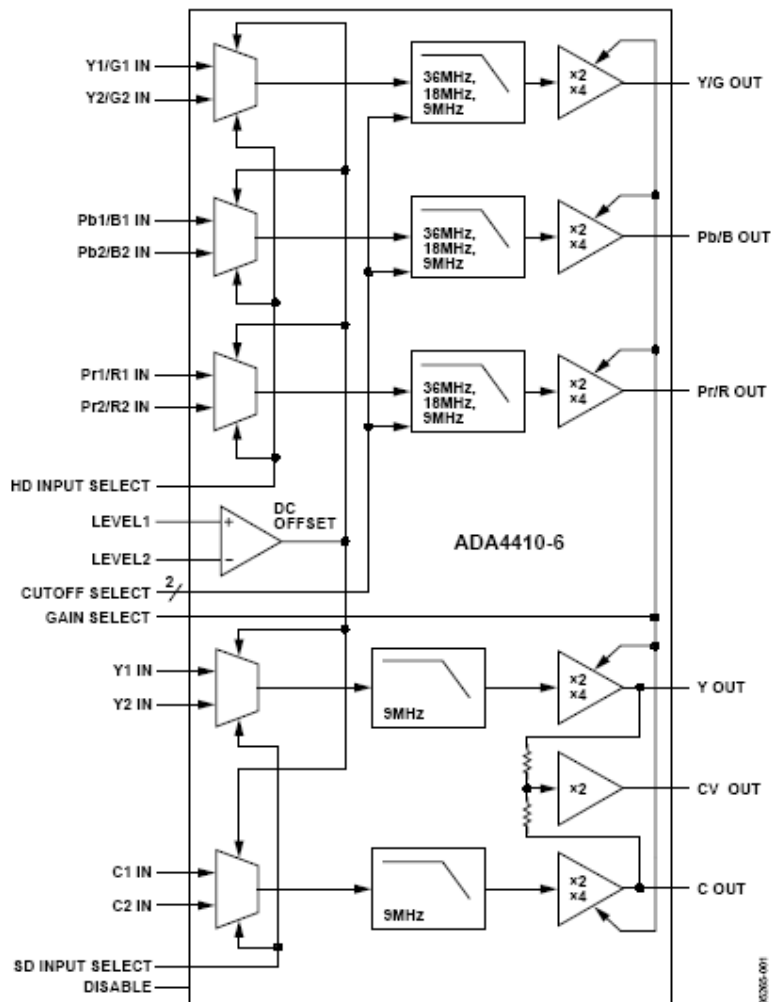
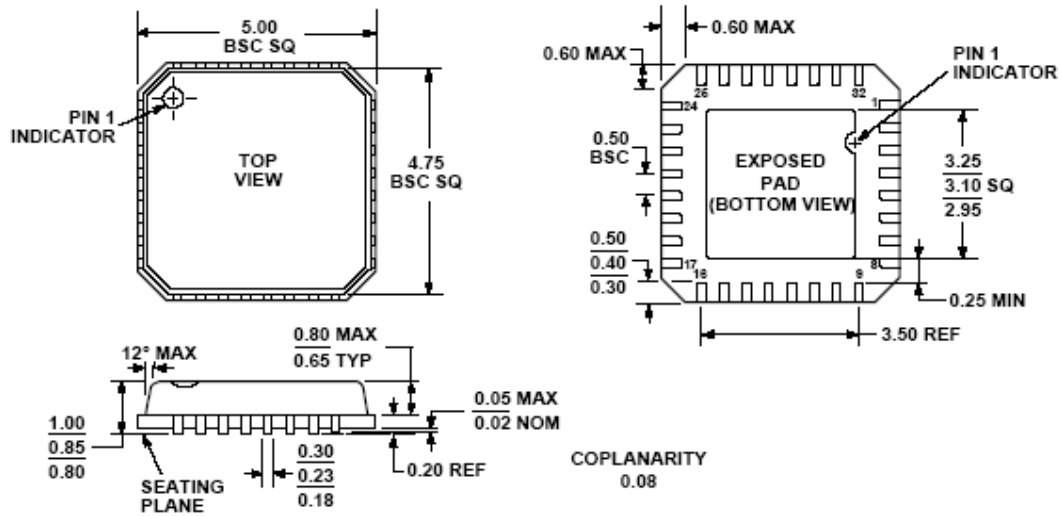

Figure 2.

4. ADA4410-6ACPZ (HDMI IC2034)

FUNCTIONAL BLOCK DIAGRAM





5. ADV7340BSTZ (HDMI IC2032)

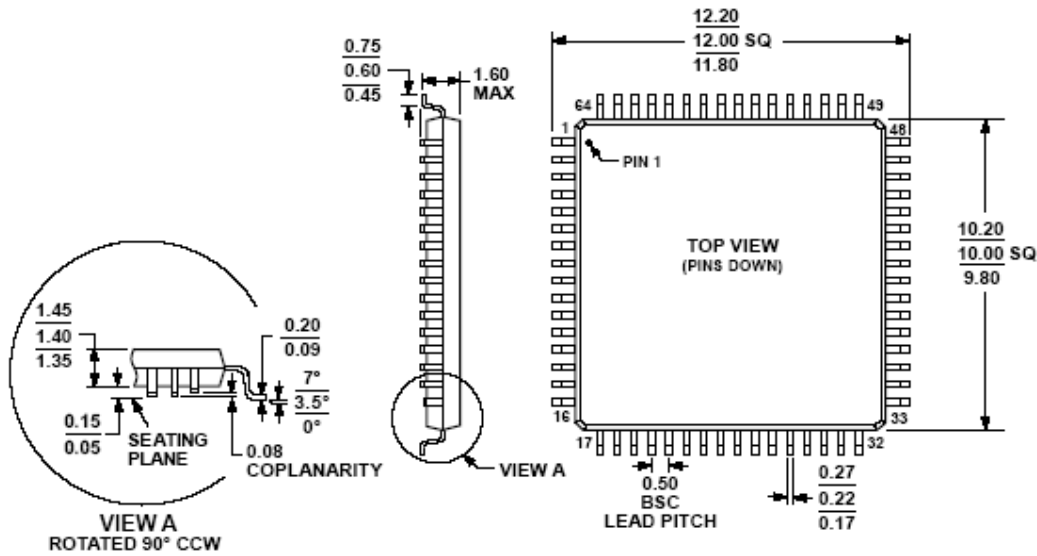

FUNCTIONAL BLOCK DIAGRAM

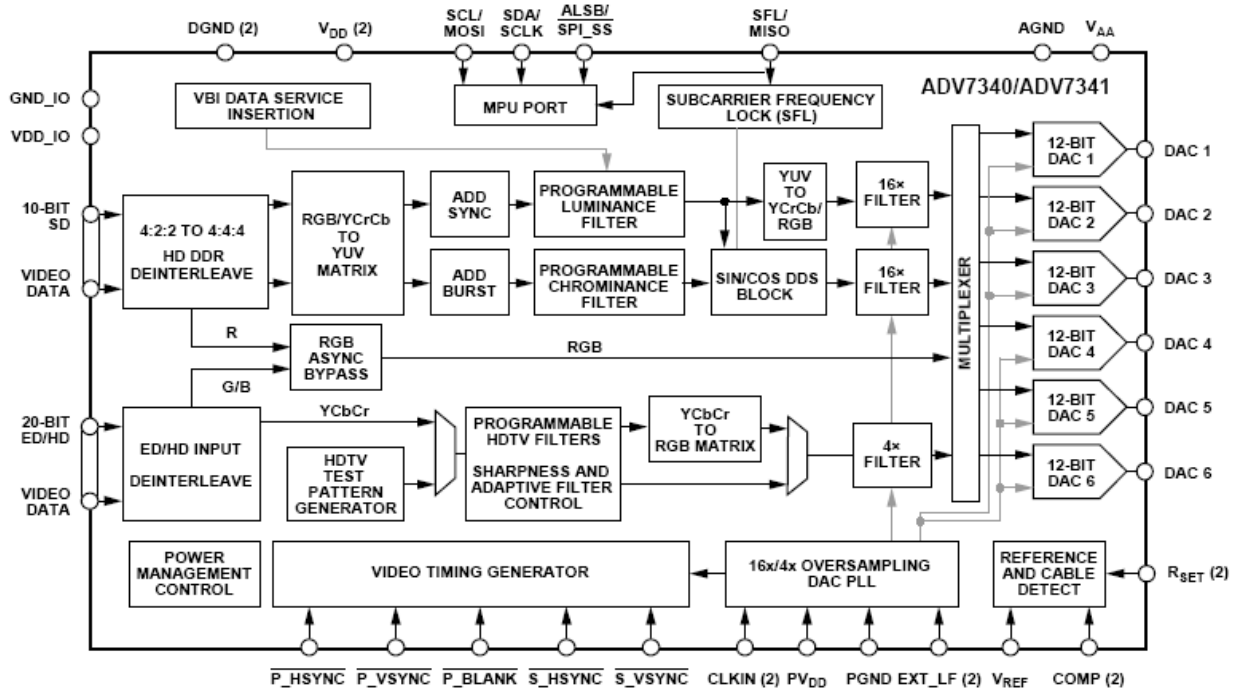

6. BU4051BCF (DSP IC4059)

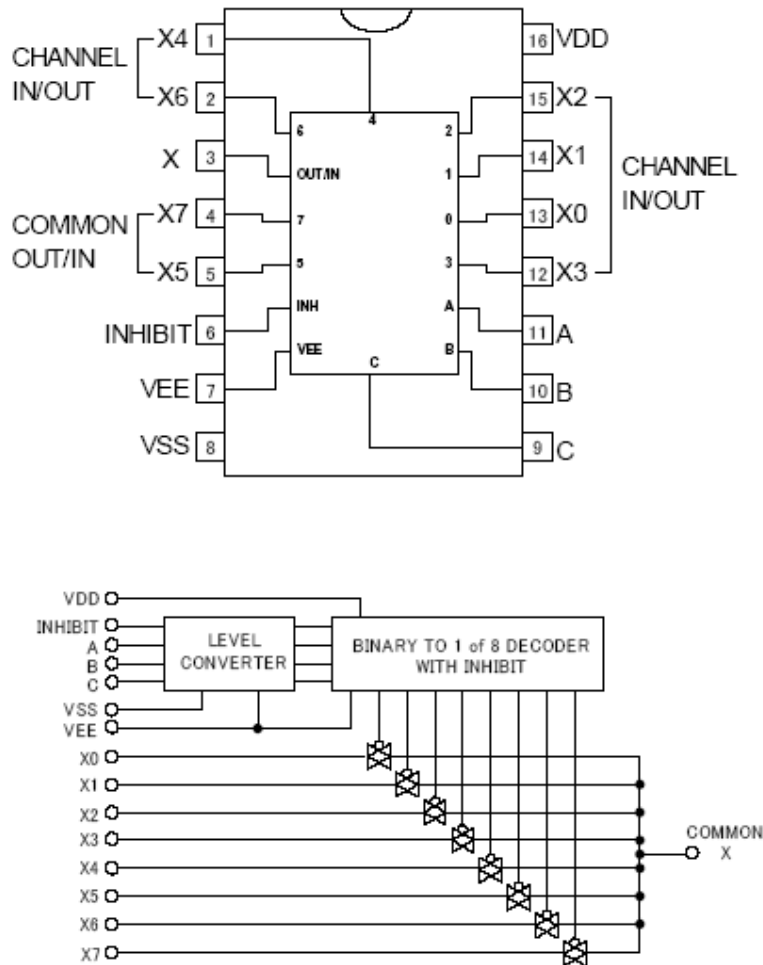

7. BU4052BCF (HDMI IC2002)

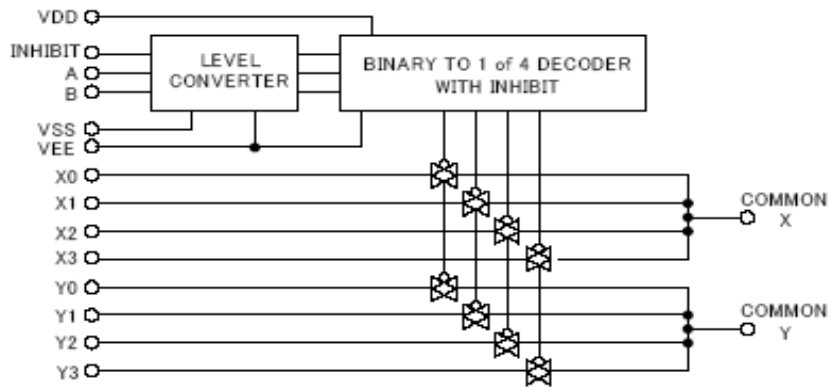
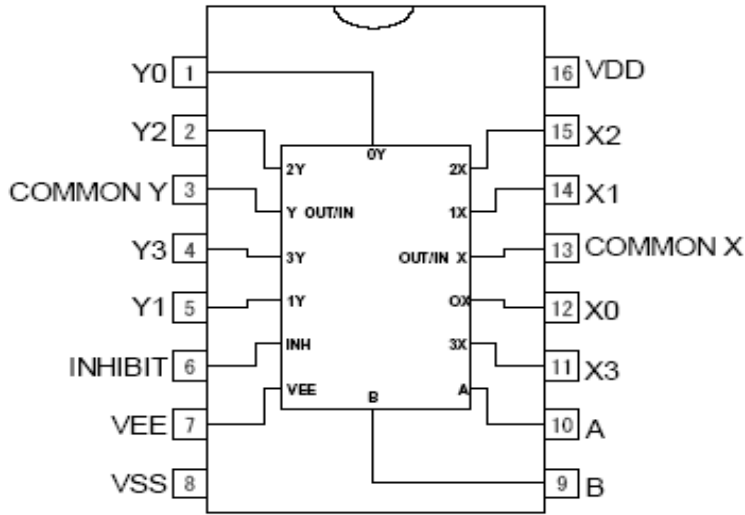

8. BU4094BCF (VIDEO: IC1513,IC1514, HDMI: IC2012, IC2013 , DSP: IC4054, IC4055, IC4057)

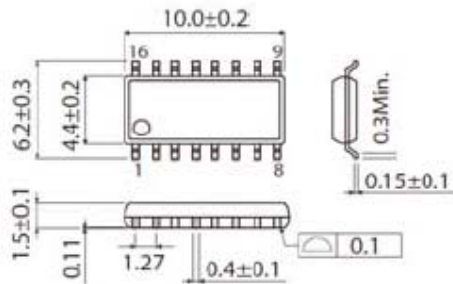

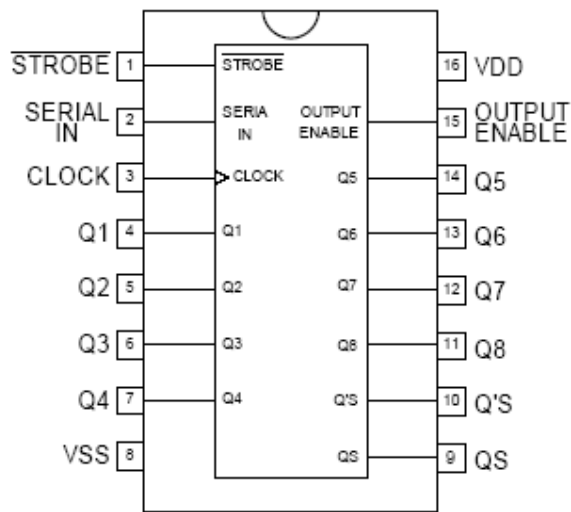
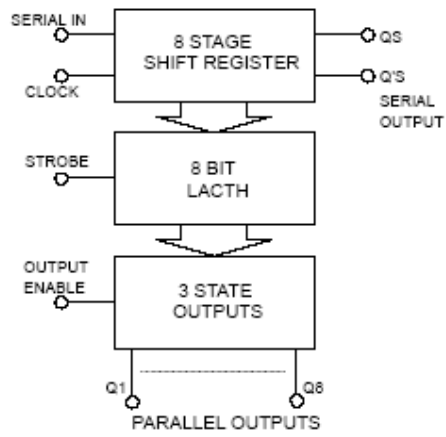

9. CD74HC4053M96 (HDMI IC2036)

CD54HC4053
(CERDIP)
CD74HC4053
(PDIP, SOIC, SOP, TSSOP)
CD74HCT4053
(PDIP, SOIC, TSSOP)
TOP VIEW

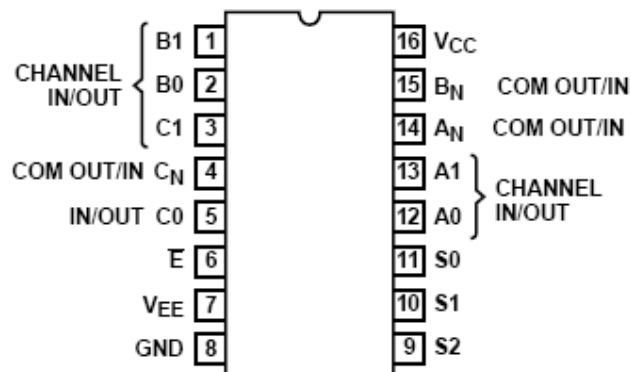

Functional Diagram of 'HC4053, CD74HCT4053

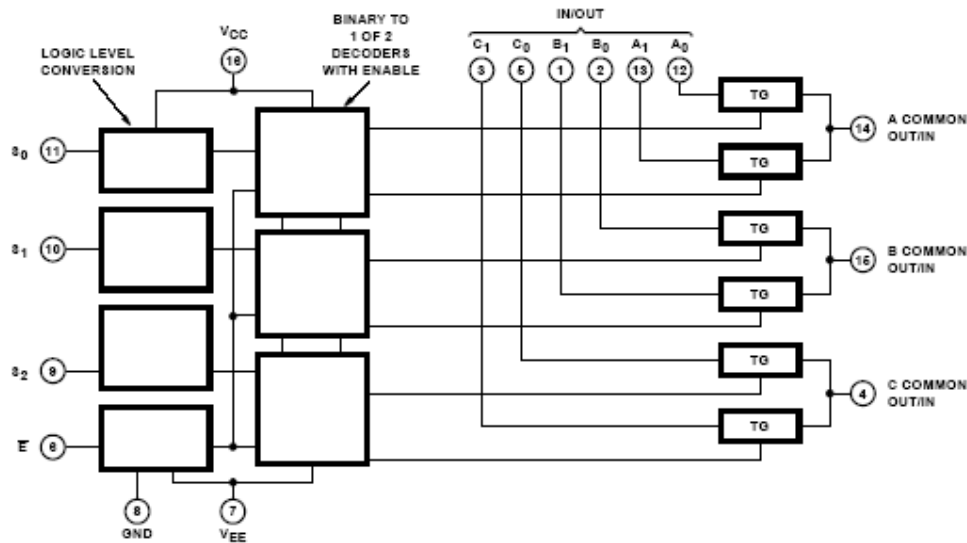

TRUTH TABLE
'HC4053, CD74HCT4053

INPUT STATES				"ON" CHANNELS
ENABLE	S ₀	S ₁	S ₂	
L	L	L	L	C0, B0, A0
L	H	L	L	C0, B0, A1
L	L	H	L	C0, B1, A0
L	H	H	L	C0, B1, A1
L	L	L	H	C1, B0, A0
L	H	L	H	C1, B0, A1
L	L	H	H	C1, B1, A0
L	H	H	H	C1, B1, A1
H	X	X	X	None

X = Don't care

10. CS4391A-KZZ (DSP IC4033,IC4038,IC4040)

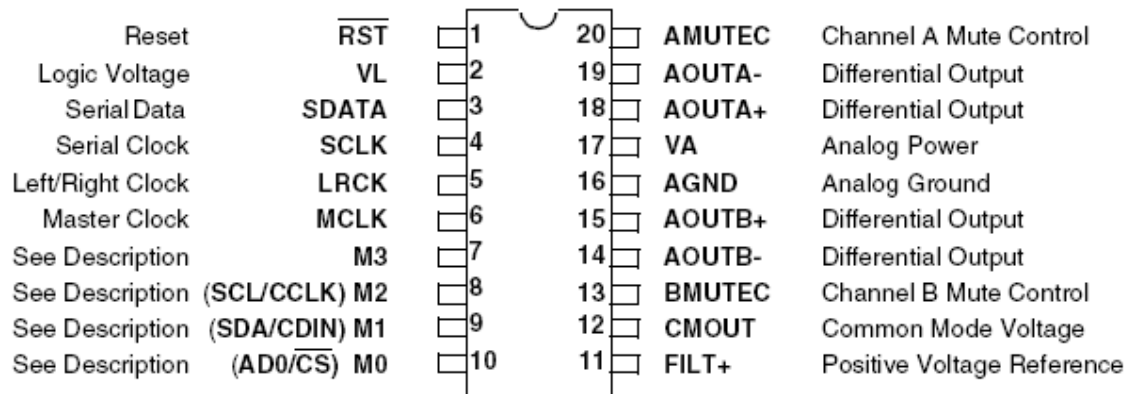

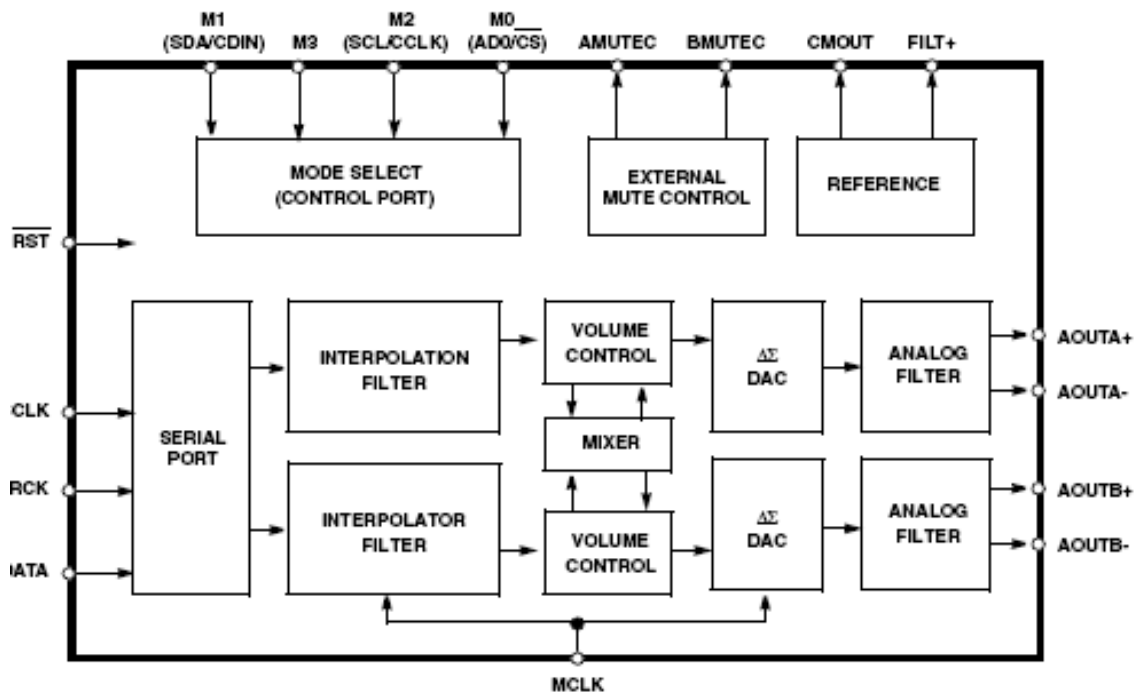

11. CS5368-CQZ (DSP IC4017)

PIN DESCRIPTION

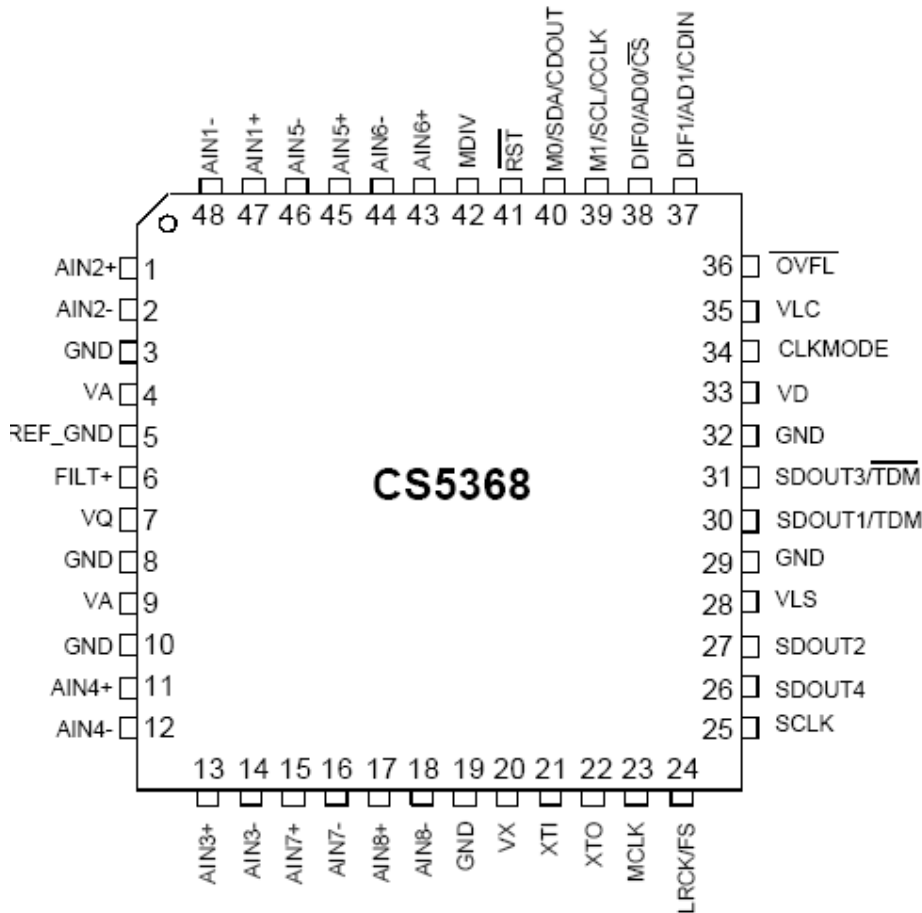

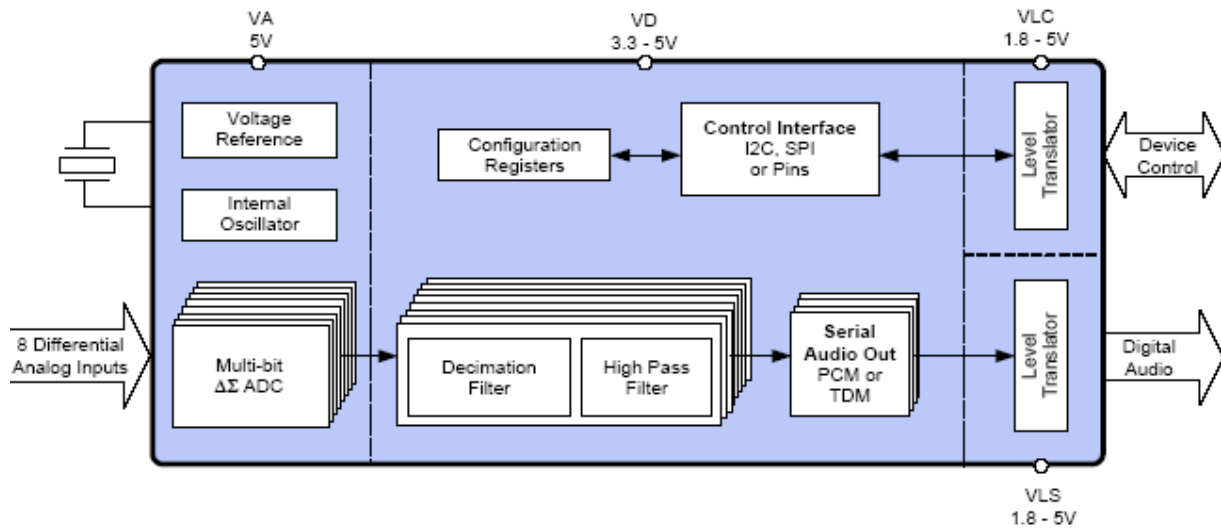

12. D790E001BZDH275 (DSP IC4023,IC4034)

Device Block Diagram

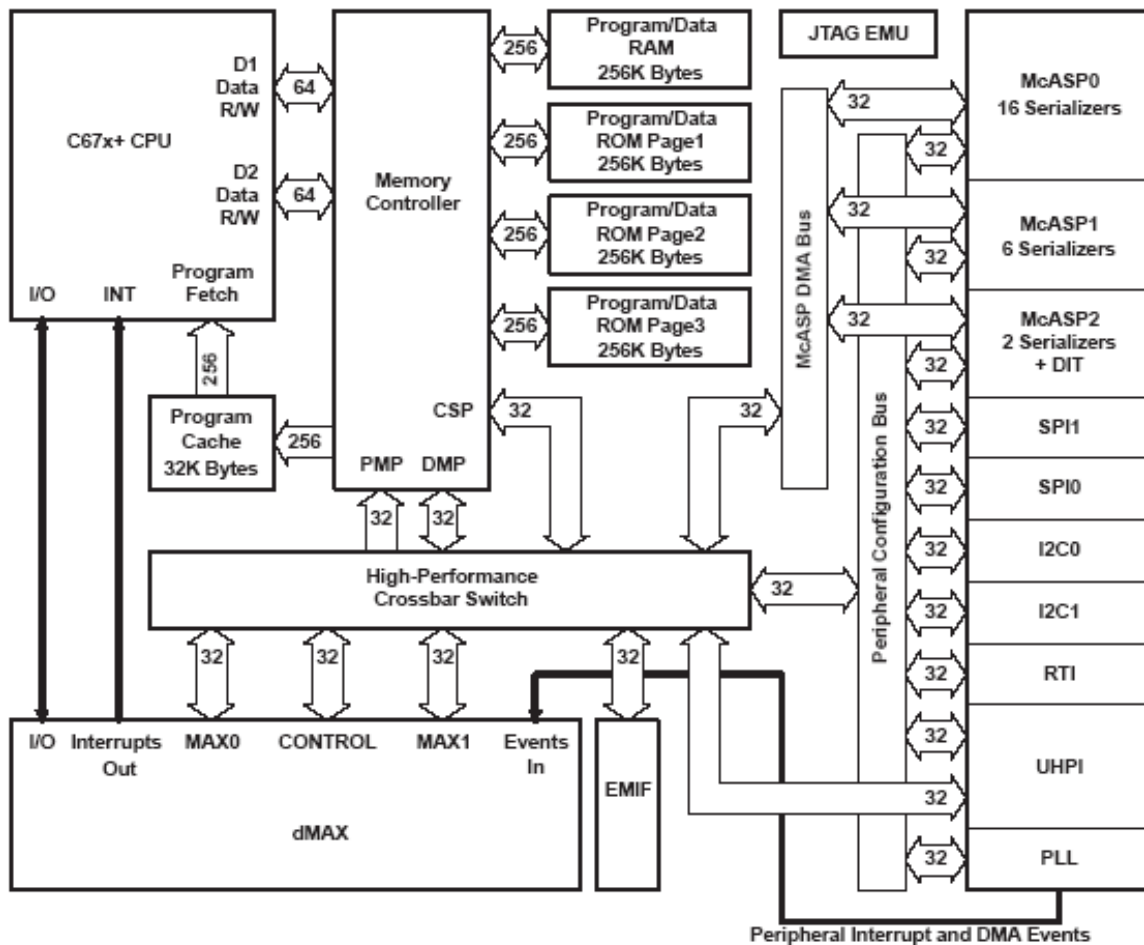

13. DM9161AEP (ETHER IC5002)

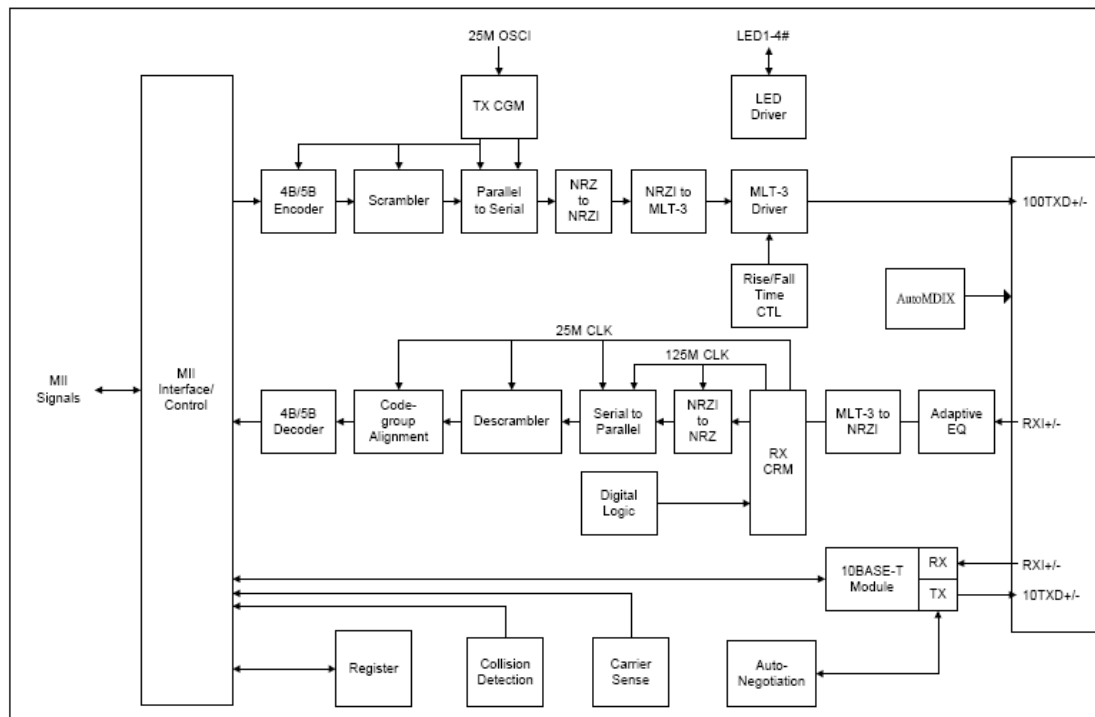
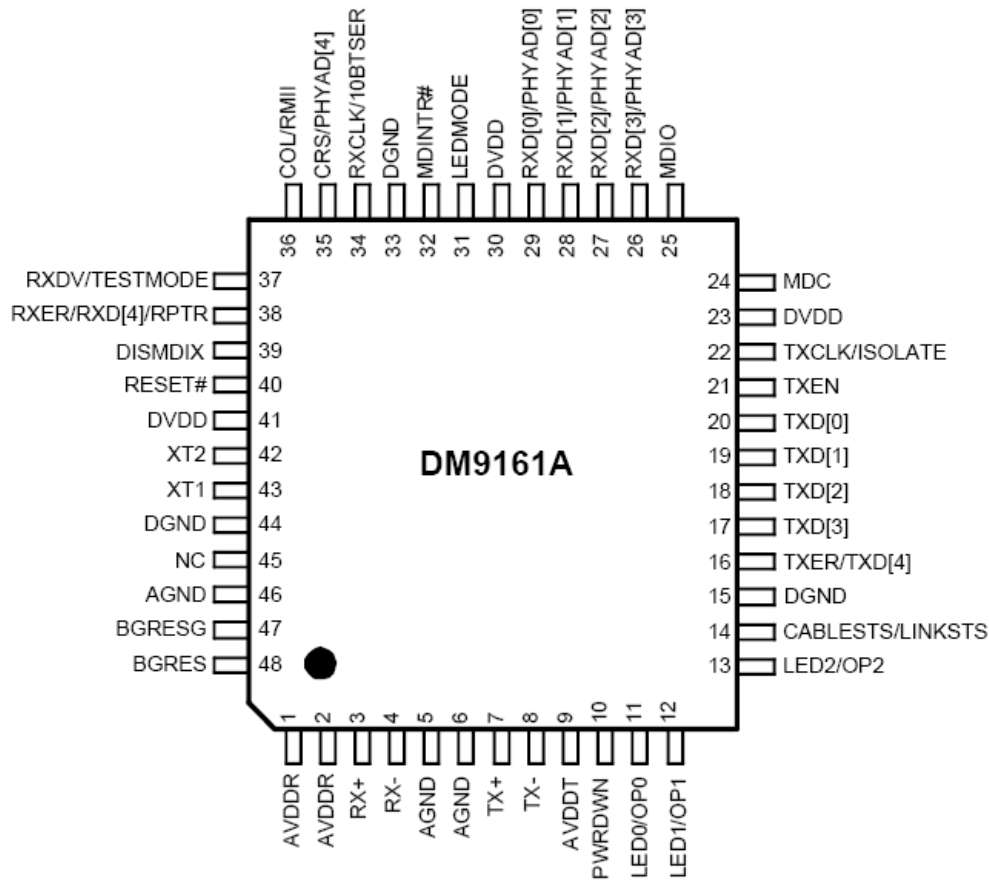

14. H1102NL SMD16 (ETHER T5000)

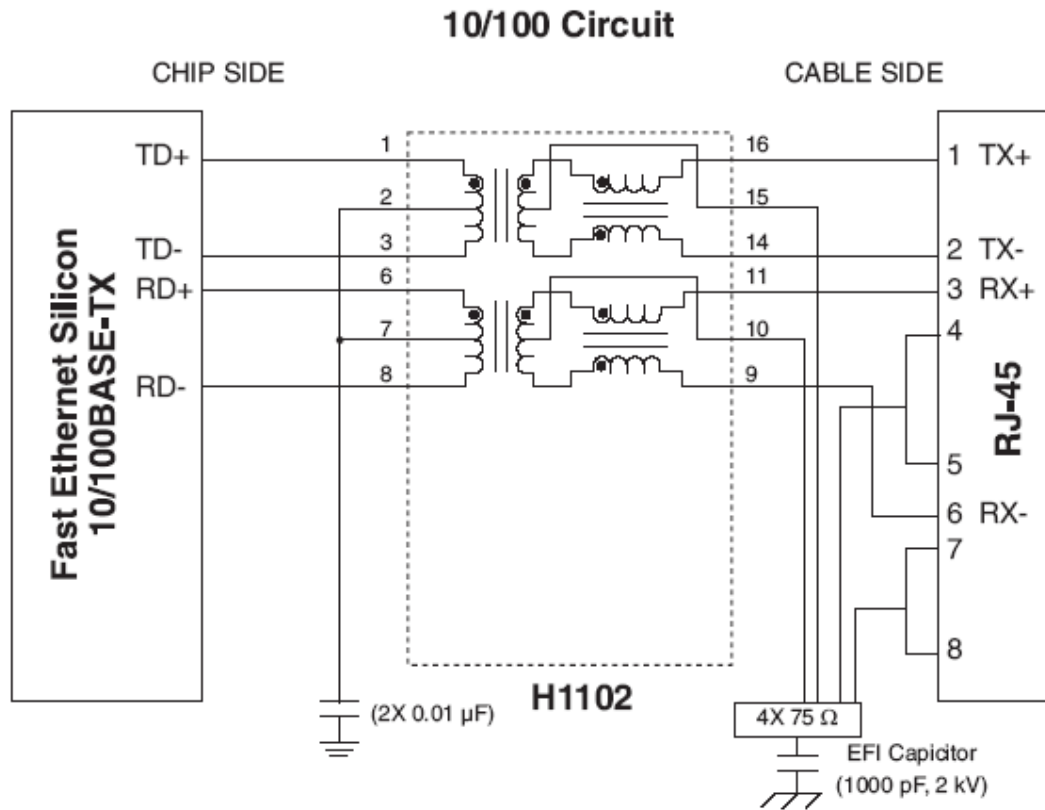

15. KIA1117F00-RTF/P (DSP IC4024, IC4035)

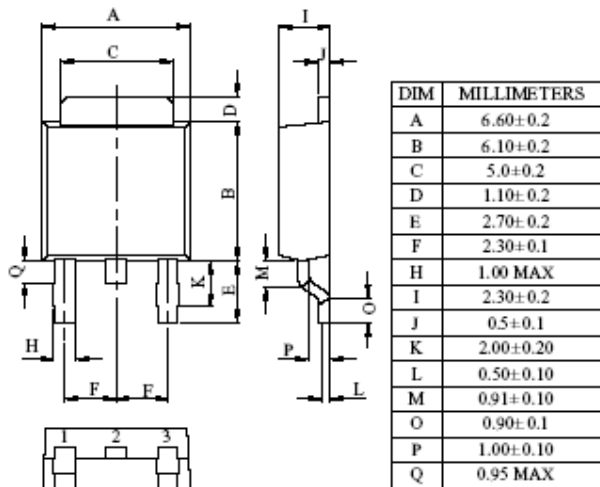

- 1. GND (Adj.)
- 2. OUTPUT
- 3. INPUT

Heat Sink is common to
⊗ (Output)

16. KIA7824API TO-220IS (MAIN IC135, IC137)

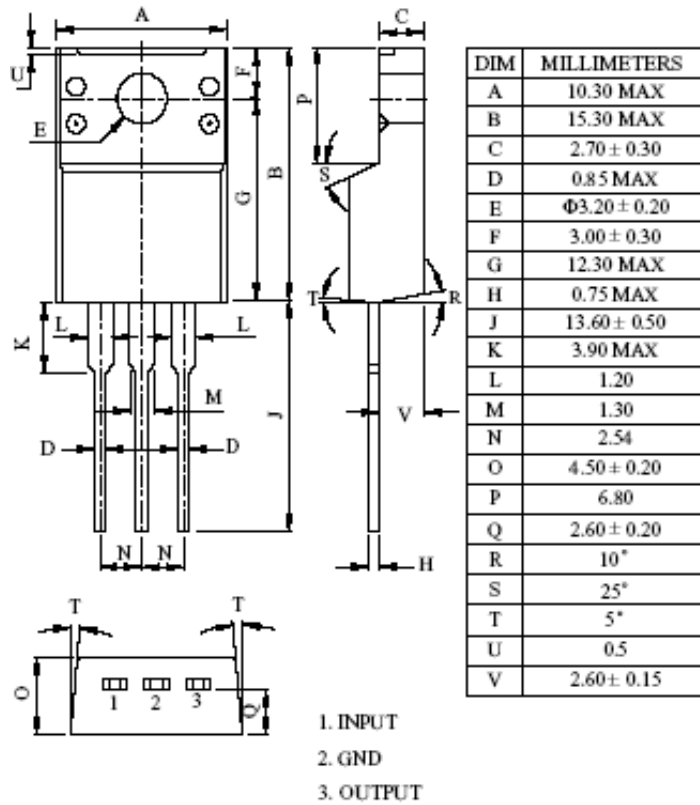

17. KIA7915PI TO-220 (MAIN IC134)
KIA7905PI TO-220 (MAIN IC803)

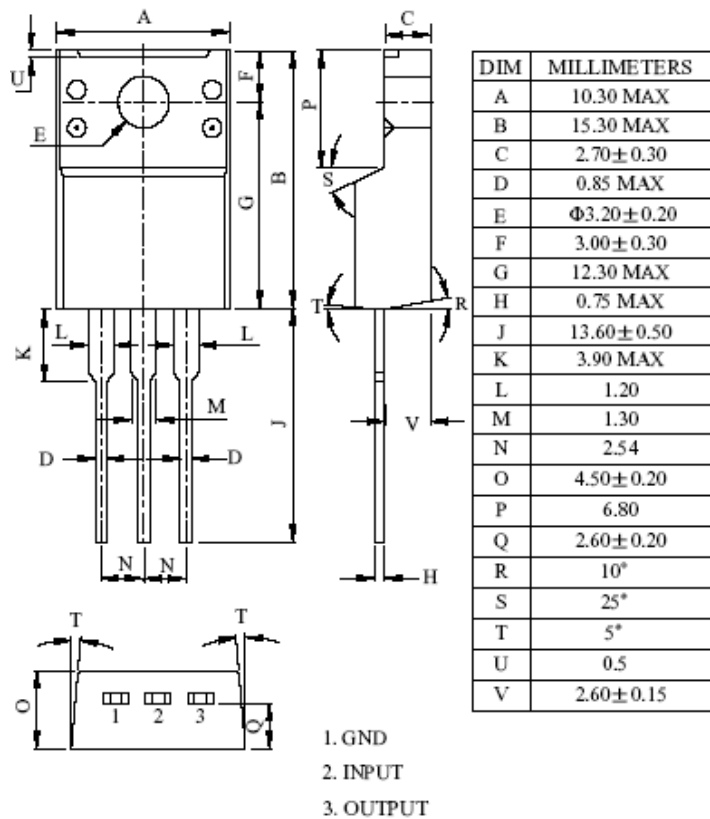

18. LM19CIZ2.4V (MAIN: IC233, SUB: Q4011)

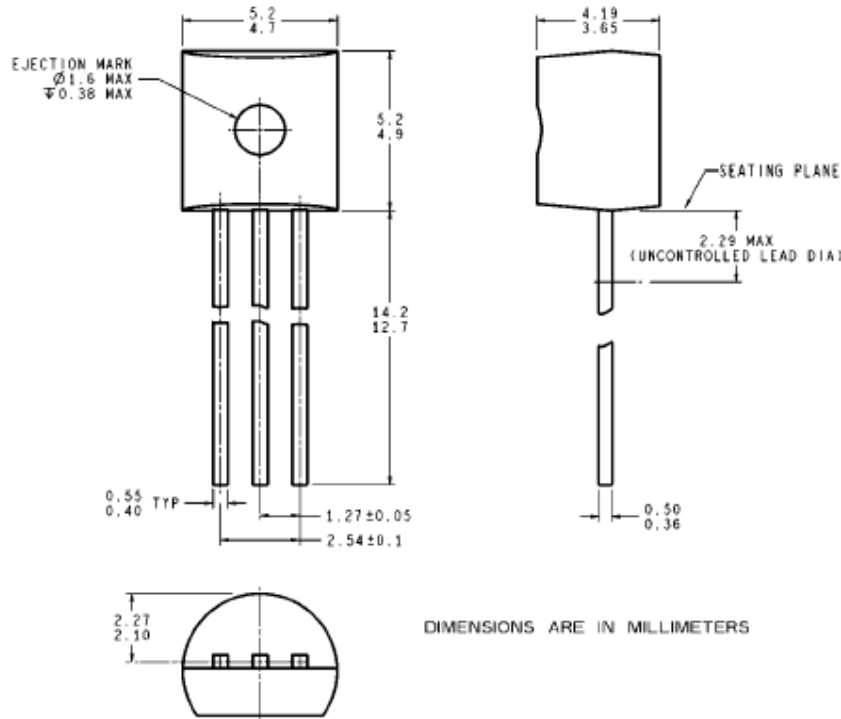

19. M12L128168Z-6TG (ETHER IC5001)

Pin Arrangement

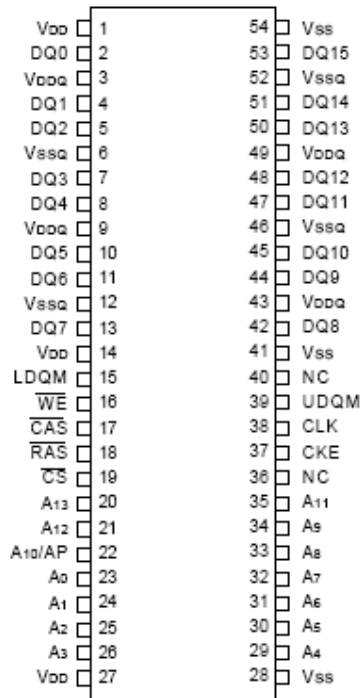

BLOCK DIAGRAM

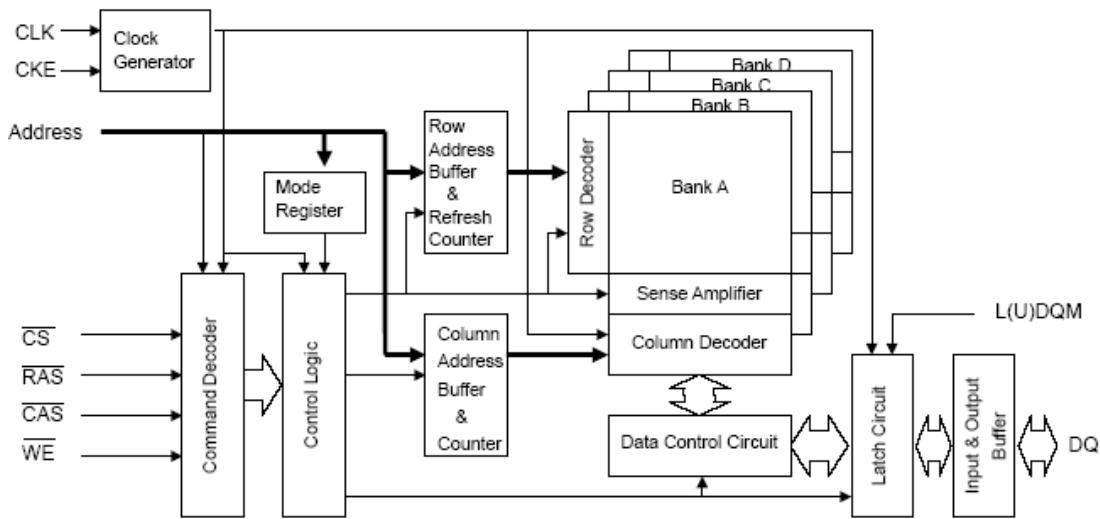

20. M12L64164A-5TG (DSP IC4022, IC4027, IC4031, IC4042)

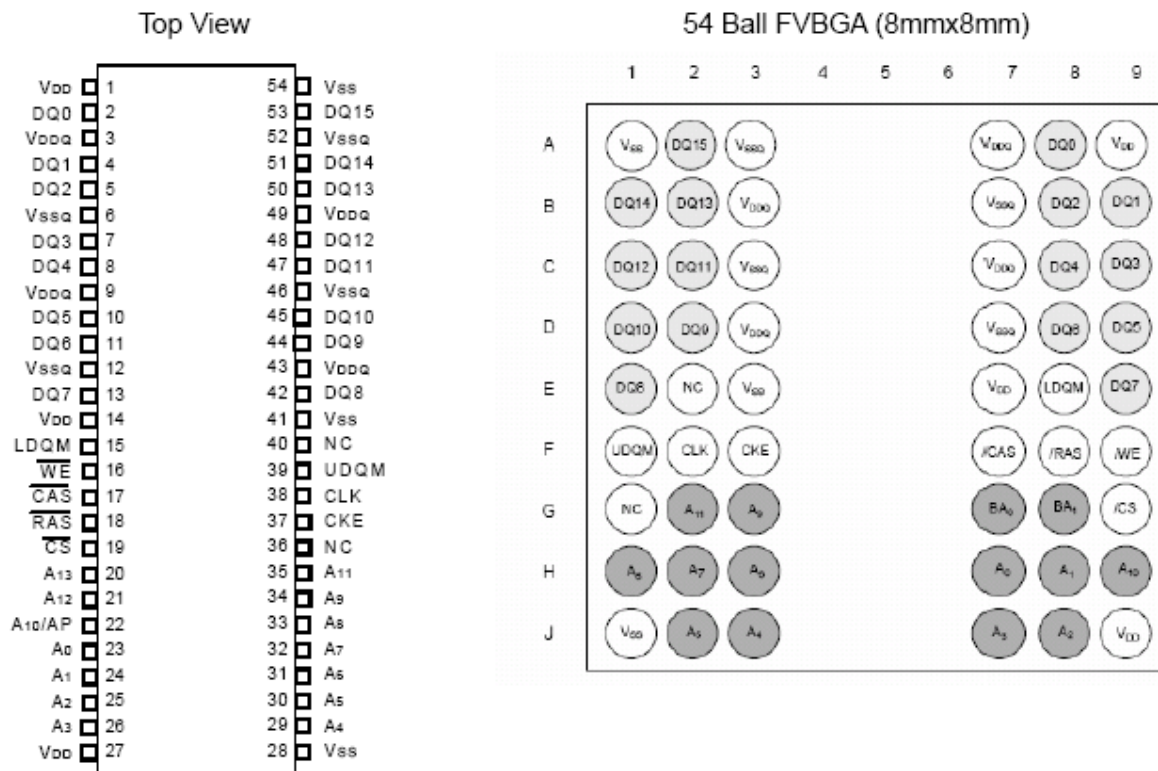

FUNCTIONAL BLOCK DIAGRAM

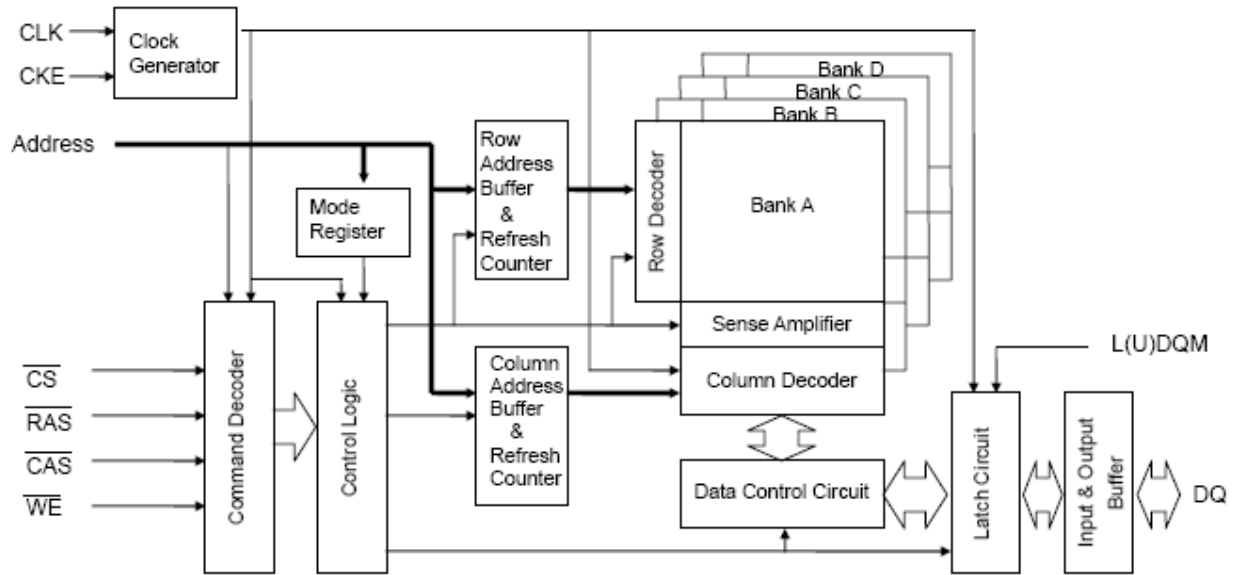

21. M24256-BWMN6TP (DSP IC4042)

M24512-W
 M24512-R
 M24256-BW
 M24256-BR

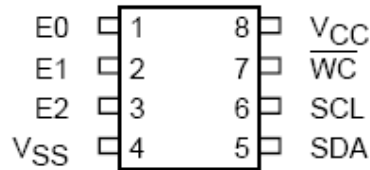

22. M24C08-WMN6TP (HDMI IC2011)

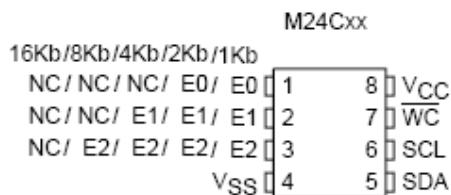

SO8 (MN)
 150 mils width

23. MAX3223CDWR (POWER IC3251)

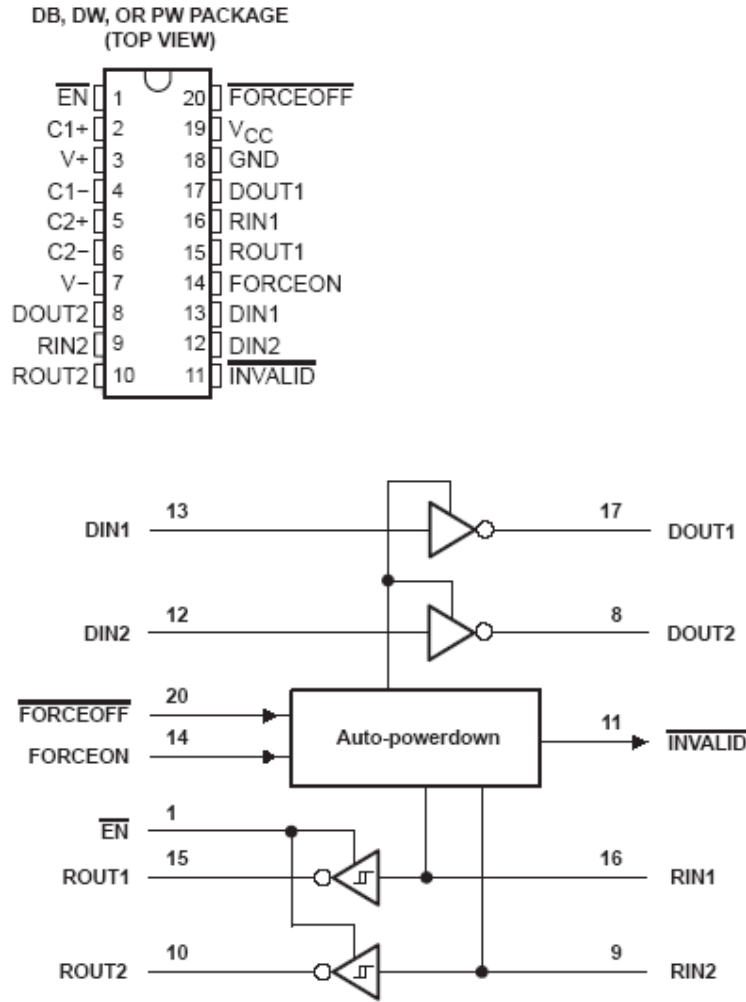

24. NJM2505AF-TE1 (VIDEO IC1505, IC1506, IC1507)

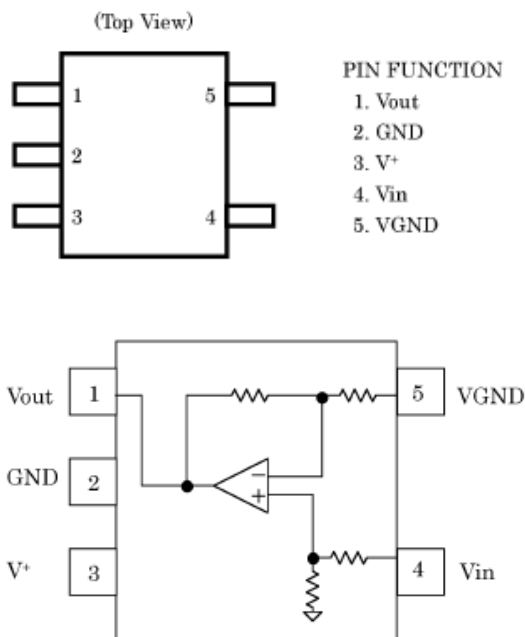

25. PC17K1CTN (HDMI: IC2000, IC2001, DSP: IC4060)

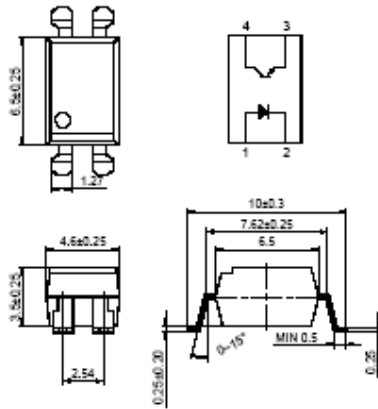

26. S29GL064N90TF1060 (ETHER IC5000)

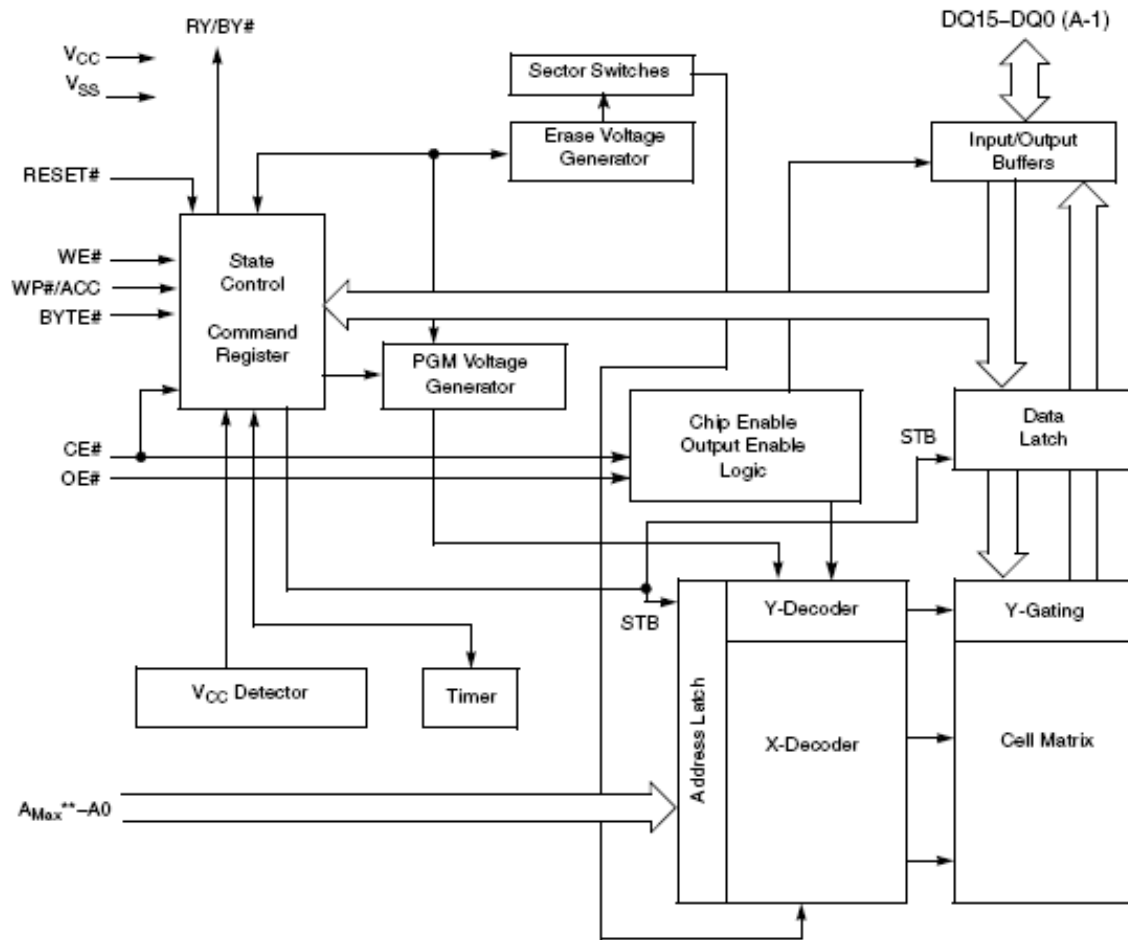

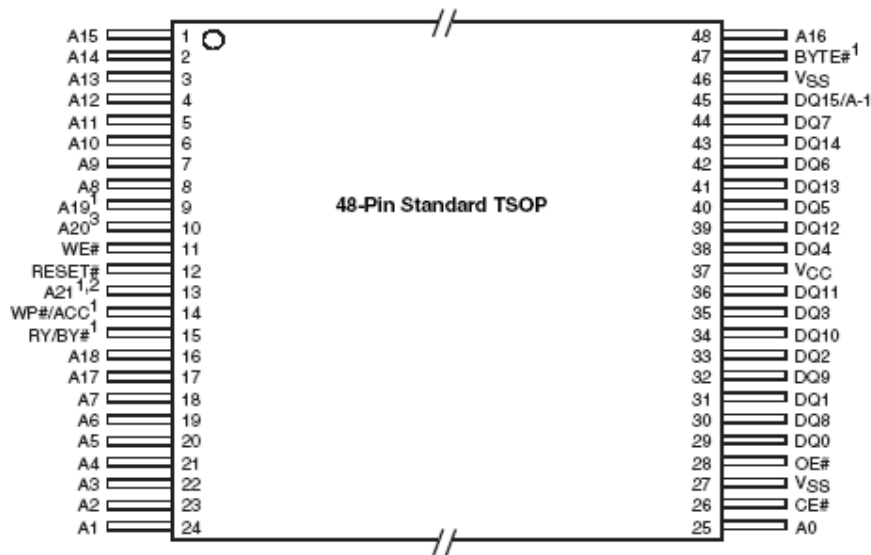

27. SC16IS740IPW (HDMI IC2007)

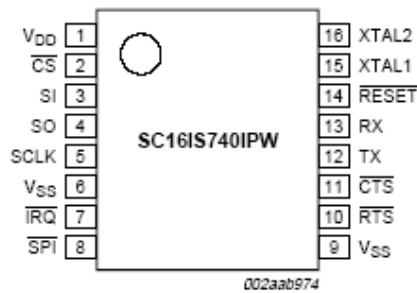
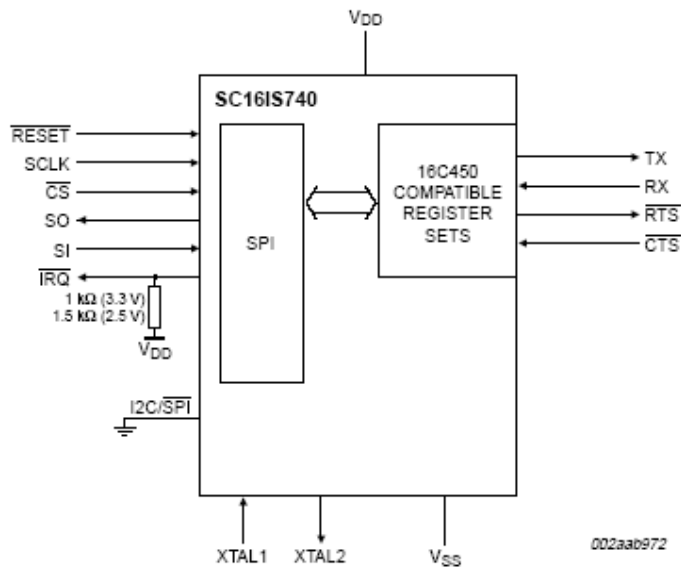

28. SN74ALVCH16827DGG (HDMI IC2021,IC2022,IC2030,IC2031)

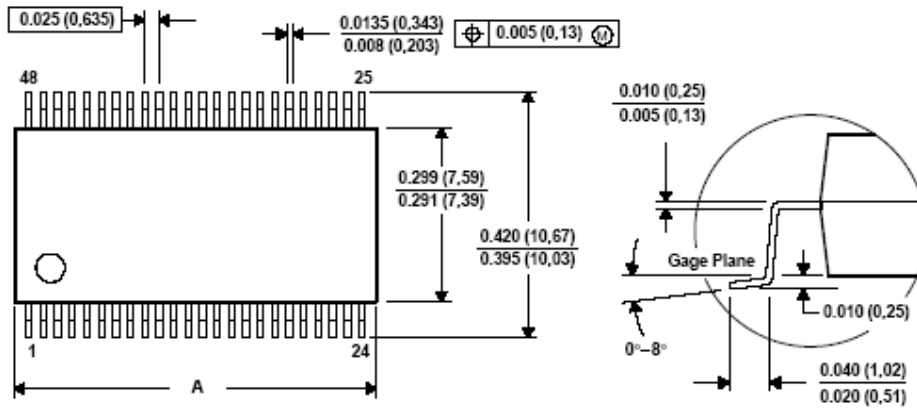

LOGIC SYMBOL⁽¹⁾

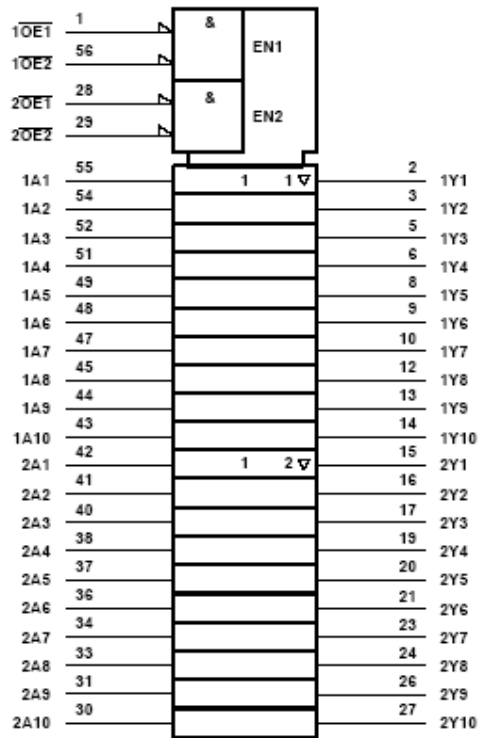

(1) This symbol is in accordance with ANSI/IEEE Std 91-1984 and IEC Publication 617-12.

29. SN74LV125APWR (DSP IC4061, IC4062)

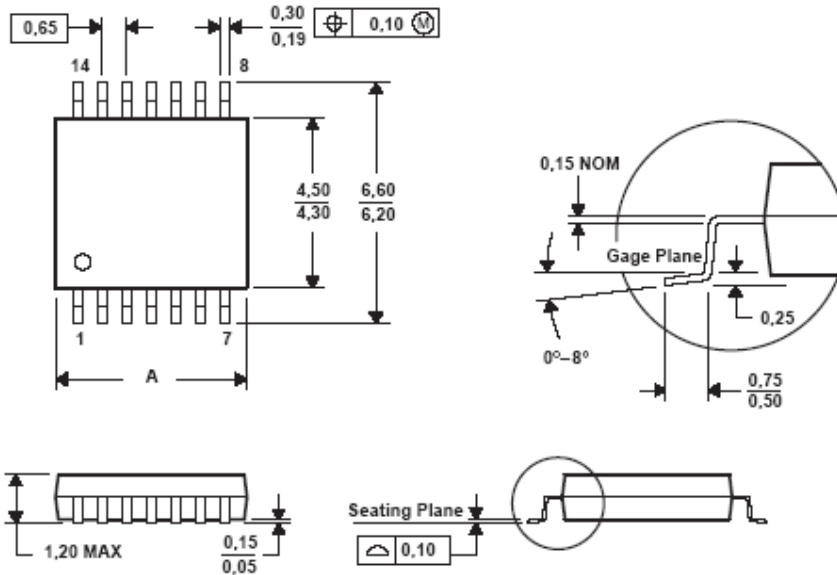

logic diagram (positive logic)

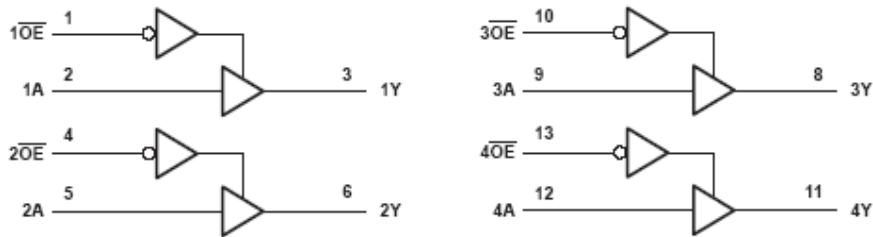

Pin numbers shown are for the D, DB, DGV, J, N, NS, PW, RGY, and W packages.

30. SN74LVC1G04DCKR (HDMI IC2037)

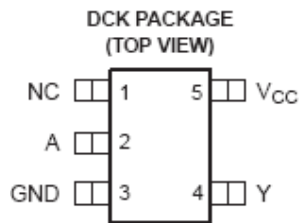

FUNCTION TABLE

INPUT A	OUTPUT Y
H	L
L	H

LOGIC DIAGRAM (POSITIVE LOGIC)
(DBV, DCK, DRL, DRY, AND YZP PACKAGE)



LOGIC DIAGRAM (POSITIVE LOGIC)
(YZV PACKAGE)

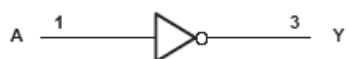

**31. SN74LVC1G125DBVR (HDMI: IC2020, IC2040
 DSP:IC4043, IC4043, IC4047, IC4048, IC4049, IC4056, IC4063)**

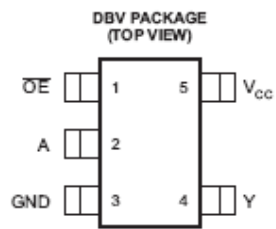

FUNCTION TABLE

INPUTS		OUTPUT
OE	A	Y
L	H	H
L	L	L
H	X	Z

LOGIC DIAGRAM (POSITIVE LOGIC)

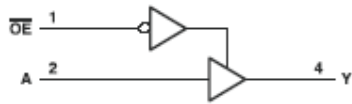

32. SN74LVC1G17DBVR SOT(SOT-23)DBV (IC4050, IC4051)

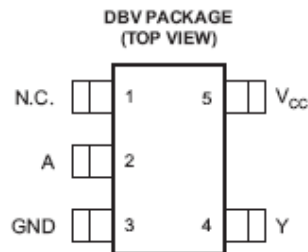

FUNCTION TABLE

INPUT	OUTPUT
A	Y
H	H
L	L

LOGIC DIAGRAM (POSITIVE LOGIC)
 (DBV, DCK, DRL, DRY, and YZP Package)



LOGIC DIAGRAM (POSITIVE LOGIC)
 (YZV Package)



33. SN74LVC257AD SOIC-16 (HDMI IC2008, IC2018)

SN54LVC257A . . . J OR W PACKAGE
 SN74LVC257A . . . D, DB, NS,
 OR PW PACKAGE
 (TOP VIEW)

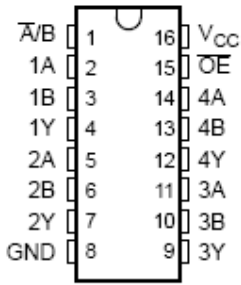

FUNCTION TABLE

OE	INPUTS			OUTPUT Y
	A/B	A	B	
H	X	X	X	Z
L	L	L	X	L
L	L	H	X	H
L	H	X	L	L
L	H	X	H	H

LOGIC DIAGRAM (POSITIVE LOGIC)

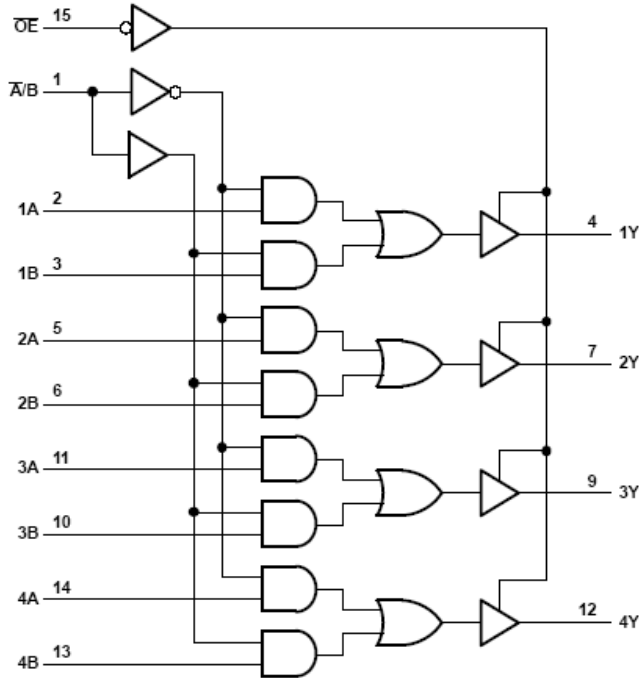

34. SN74LVC827APWR (HDMI IC2014)

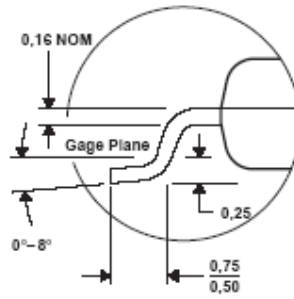
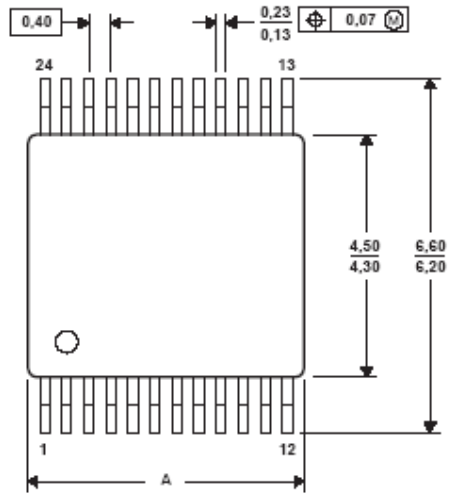

DB, DGV, DW, NS, OR PW PACKAGE
(TOP VIEW)

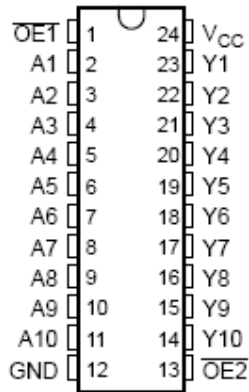

FUNCTION TABLE

INPUTS			OUTPUT Y
OE1	OE2	A	
L	L	L	L
L	L	H	H
H	X	X	Z
X	H	X	Z

LOGIC DIAGRAM (POSITIVE LOGIC)

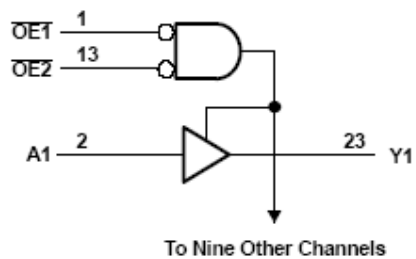

35. UPD70F3718GC8EAA (DSP IC4041)

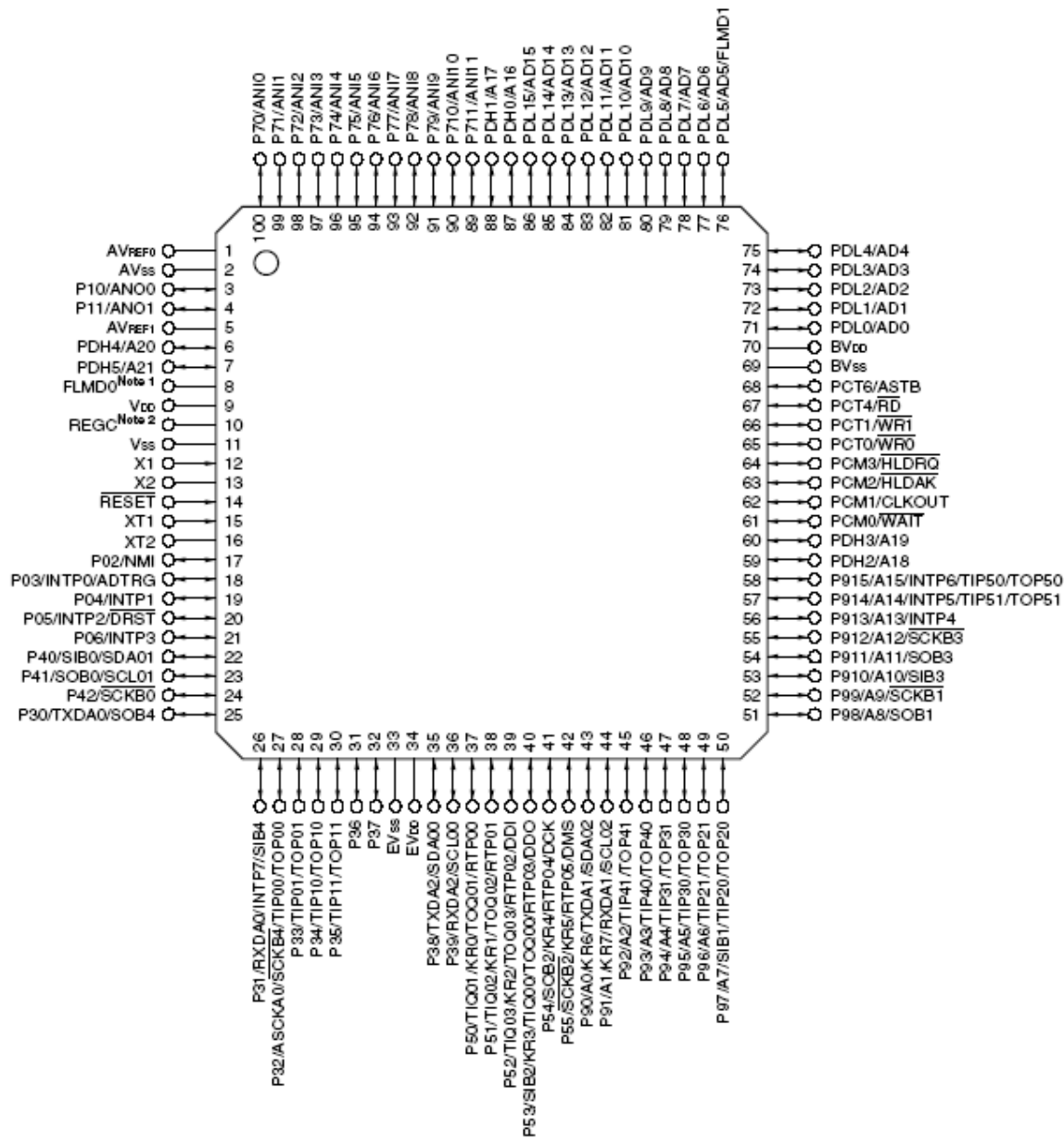

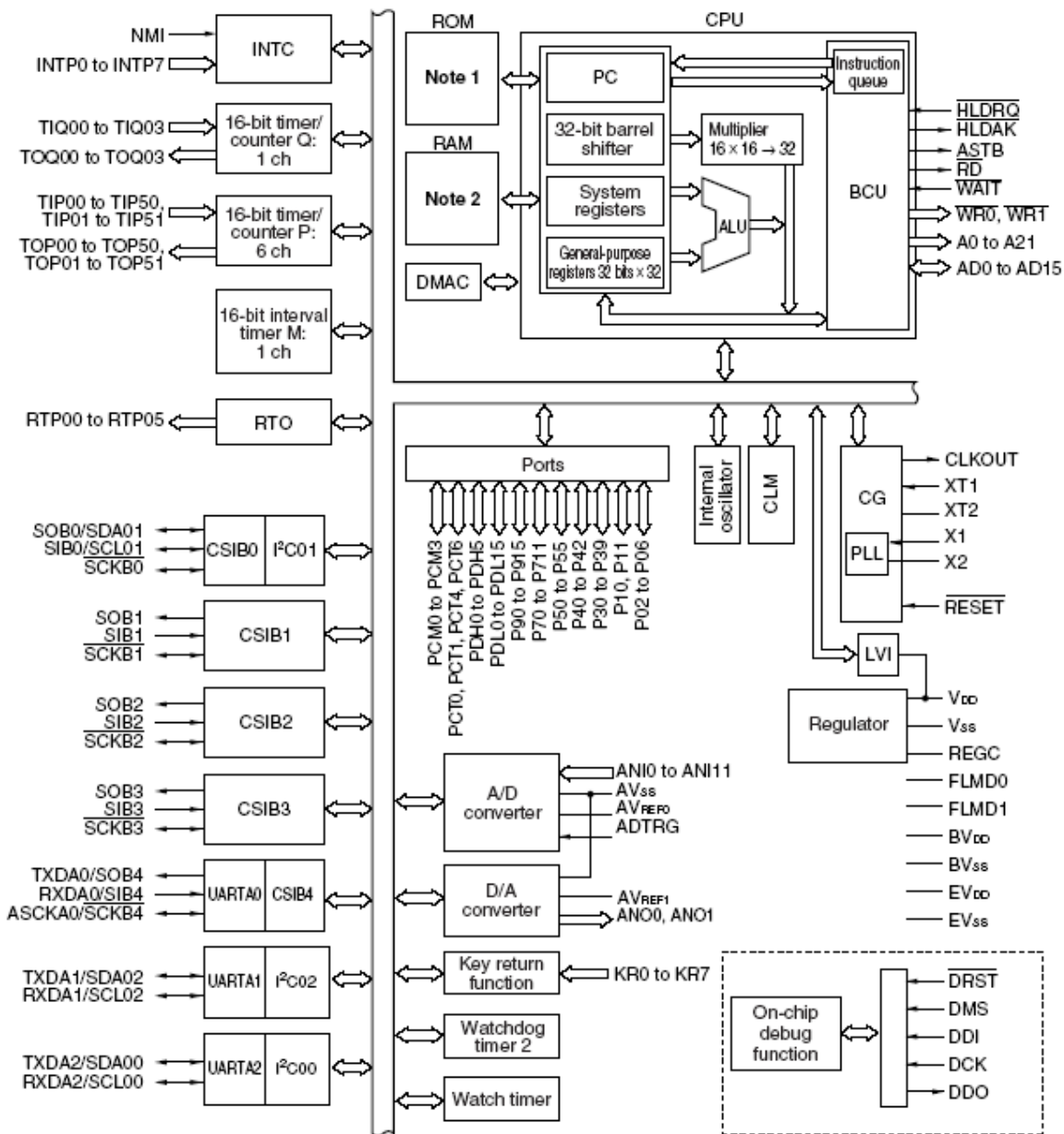

36. XC9572XL-5VQG64C VQG64(DSP IC4015)

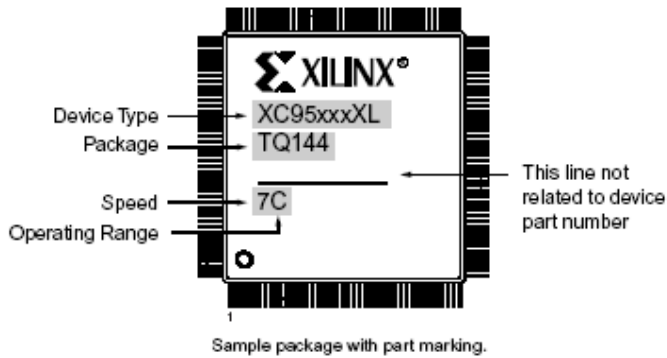
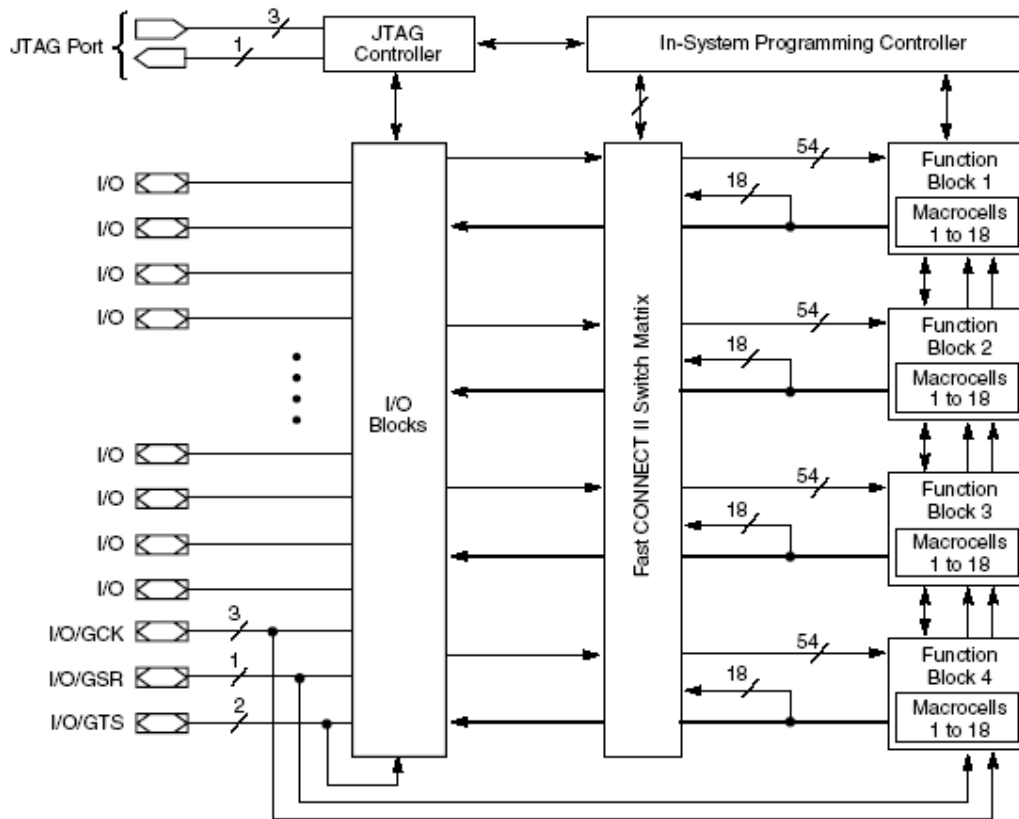

- 37. KIA278R05PI (SURROUND: IC802)
- KIA278R06PI (MAIN: IC232)
- KIA278R12PI (MAIN: IC132)
- KIA278R15PI(MAIN: IC133)
- KICA27833PI (HDMI: IC2035)

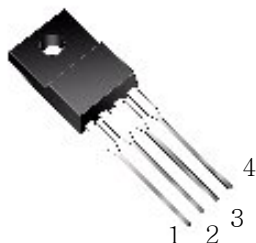

- ① DC INPUT (V_{IN})
- ② DC OUTPUT (V_O)
- ③ GND
- ④ ON/OFF CONTROL

- 38. KIA7805API(MAIN: IC231)
- KIA7806API(VIDEO: IC1517)
- KIA7812API(MAIN : IC131, IC136)
- KIA78R05PI(POWR:)



- 1. INPUT
- 2. COMMON
- 3. OUTPUT

- 39. KIA7905API(SURROUND : IC803)
- KIA7915AP(MAIN : IC134)



- 2. COMMON
- 3. INPUT
- 4. OUTPUT

- 40. LM1117S-1VS (HDMI : IC2015, IC2017,IC2033 / ETHER: IC5005)
- LM1117S-2V5 (HDMI : IC2028)
- LM1117S-3V3 (HDMI : IC2023/ DSP; IC4035)

SOT-223 PKG (FRONT VIEW)

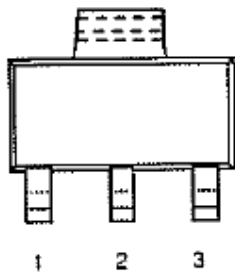

- PIN FUNCTION
- 1. Adj/Gnd
 - 2. Vout
 - 3. Vin

- 41. NJM2068M (PROCESSOR : IC1002,IC1004,IC1005, IC1008~IC1013, IC1015,IC1016

IC1018~IC1025/ FRONT: IC3501, DSP: IC4001~IC4004, IC4006~IC4013, IC4018, IC4025, IC4028, IC4032, IC4037, IC4039, IC4052, IC4053)

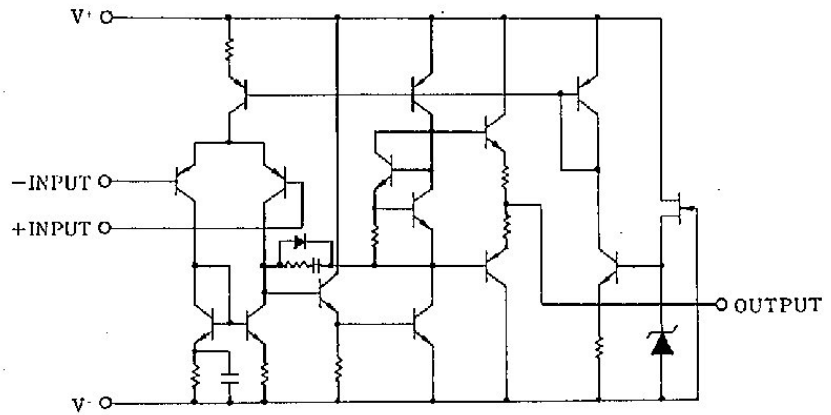

42. NJM2296(VIDEO IC1501~IC1504, IC1521)

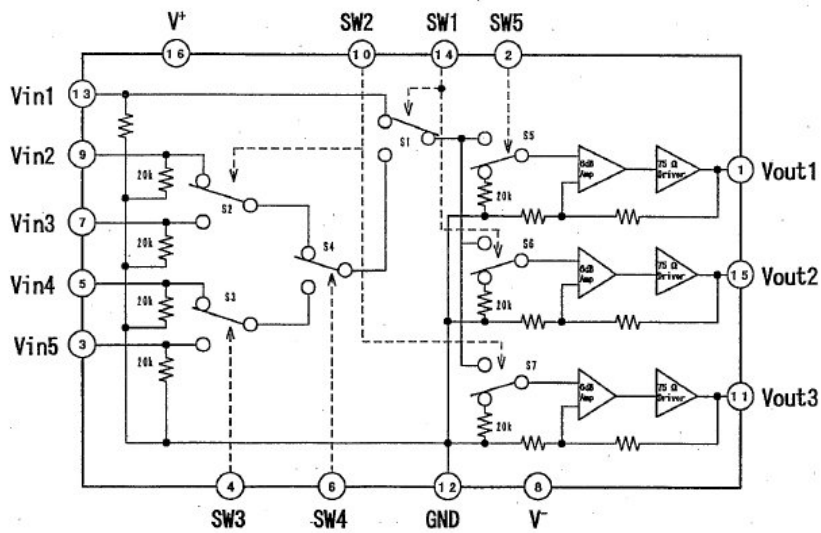
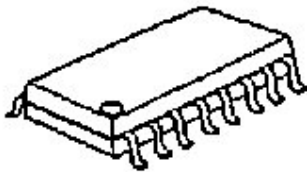

43. NJM4556AD(PROCESSOR: IC1014)

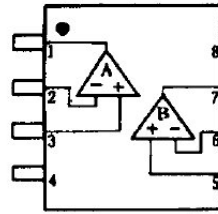

- PIN FUNCTION**
- 1.A OUTPUT
 - 2.A -INPUT
 - 3.A +INPUT
 - 4.V⁻
 - 5.B +INPUT
 - 6.B -INPUT
 - 7.B OUTPUT
 - 8.V⁺

44. LC74763M (VIDEO: IC1518)

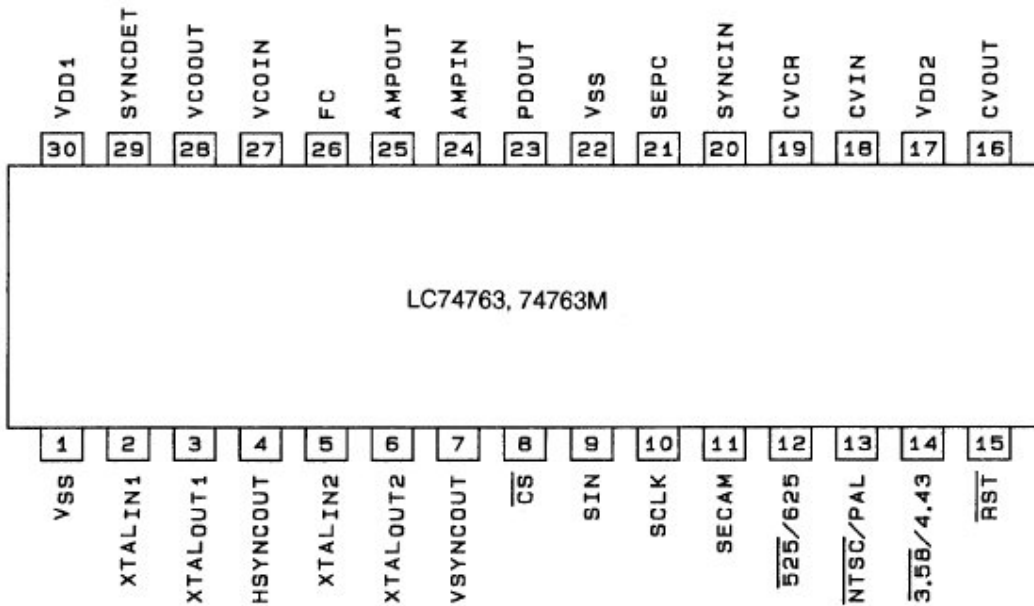

Top View

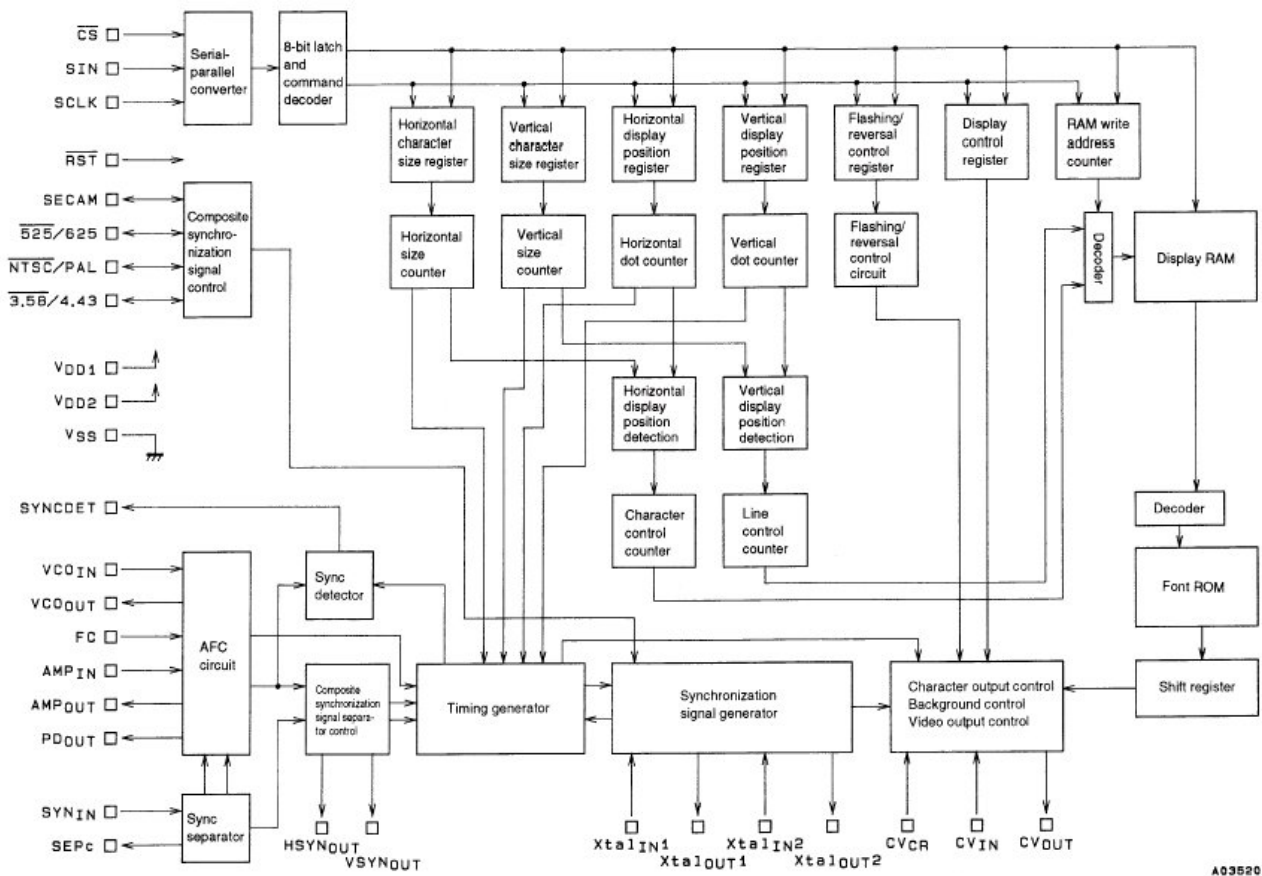

A03520

45. TC9273CFG-004(PROCESSOR: IC1000,IC1017)

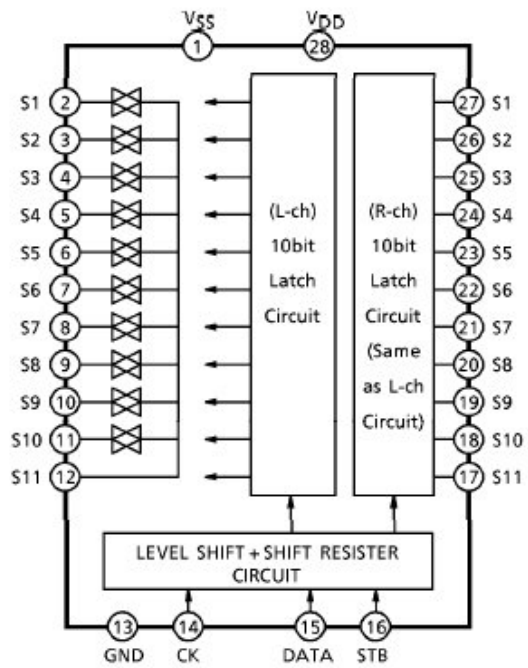
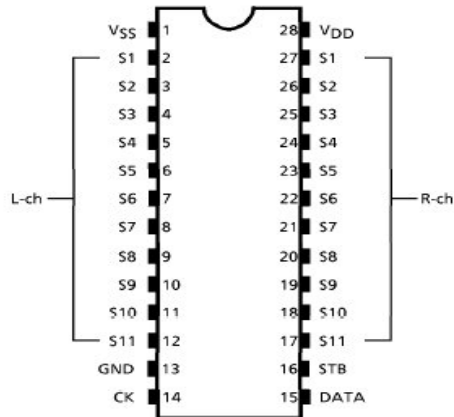
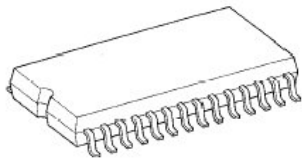

●TRANSISTORS

1.KRA107S (PROCESSOR : Q1028,Q1029,Q1038,Q1039,Q1046,Q1049~Q1052
VIDEO: Q1505, FRONT: Q3505)

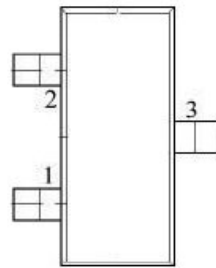
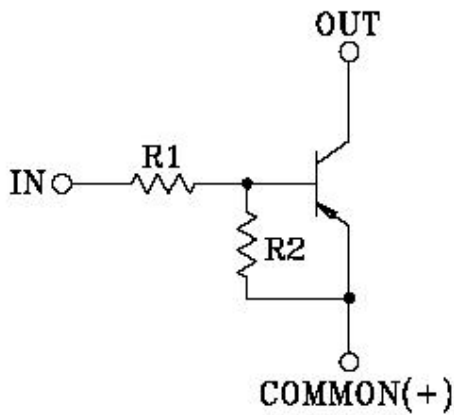

- 1. COMMON (EMITTER)
- 2. IN (BASE)
- 3. OUT (COLLECTOR)

2. KRC107S(PROCESSOR: Q1031, VIDEO: Q1506, HDMI: Q2008~Q2011,
FRONT: Q3505,Q3507~Q3509, DSP: Q4000~Q4007, Q4009, Q4013~4016,Q4018~Q4020)

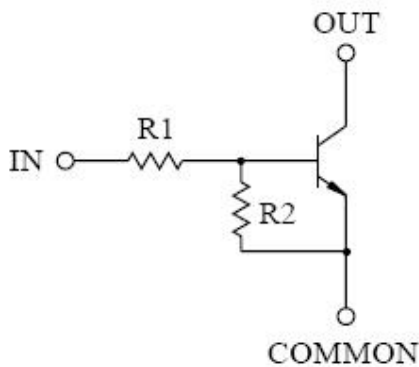

3. KTC3199-GR (VIDEO: Q1501,Q1502)
KTA1267-GR (VIDEO: Q1503,Q1504)

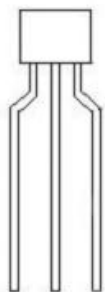

- (1) Emitter
- (2) Collector
- (3) Base

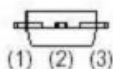

4. KTA1504Y (HDMI: Q2004, Q2005, Q2012,Q2013, FRONT: Q3503)

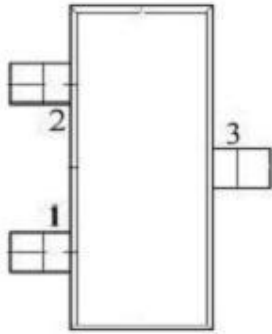

- 1. COMMON (EMITTER)
- 2. IN (BASE)
- 3. OUT (COLLECTOR)

5. KTC3875S (FRONT: Q3501,Q3502, ETHER: Q5001)

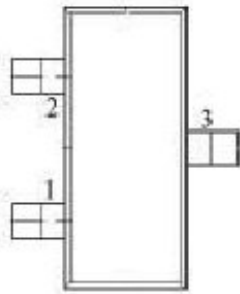

- 1. COMMON (EMITTER)
- 2. IN (BASE)
- 3. OUT (COLLECTOR)

**6. KTA1360 (MAIN: Q327,Q328,Q431,Q432, SURROUND: Q515,Q516,Q715)
KTC3423 (MAIN: Q323,Q324,Q429,Q430, SURROUND: QQ513,Q613,Q713)**



- 1. EMITTER
- 2. COLLECTOR
- 3. BASE

7. 2SA1859A (MAIN: Q329 Q330 Q433 Q434 SURROUND: Q516 Q616 Q716)
 2SC4883A (MAIN: Q331 Q332 Q435 Q436 SURROUND: Q517 Q617 Q717)



1.BASE
 2.COLLECTOR
 3.EMITTOR

8. KTA1268GR (MAIN: Q181 Q311 Q312 Q410 Q414 SURROUND: Q506 Q606 Q706)
 KTC3198Y (MAIN: Q307 Q308 Q407 Q408 Q426 Q441 SURROUND: 5204 Q604 Q704)
 KTC3200GR (MAIN: Q301 Q302 Q303 Q304 Q305 Q306 Q313 Q314 Q337 Q338 Q401 Q402
 Q403 Q404 Q405 Q406 Q409 Q415 Q416 Q425)
 (SURROUND: Q501 Q502 Q503 Q507 Q520 Q601 Q602 Q603 Q607 Q620
 Q701 Q702 Q703 Q707 Q720)
 MPSA06 (POWER: 3001,Q3002, FRONT: Q3506, DSP: Q4008)



1. EMITTER
 2. COLLECTOR
 3. BASE

9. KTA1024Y (MAIN: Q182 Q315 Q316 Q319 Q320 Q417 Q418 Q421 Q422 Q442
 SURROUND: Q508 Q511 Q608 Q611 Q708 Q711)
 KTC3206Y (MAIN: Q317 Q318 Q321 Q322 Q419 Q420 Q423 Q424
 SURROUND: Q509 Q512 Q609 Q612 Q709 Q712)



1. EMITTER
 2. COLLECTOR
 3. BASE

**10. KRA107M (HDMI: Q2000 Q2001, DSP: Q4010)
KRC107M (MAIN: Q131 Q201 Q443)**



- 1. EMITTER
- 2. COLLECTOR
- 3. BASE

11. 2SA1145Y (MAIN: Q309 Q310 Q411 Q412 SURROUND: Q505 Q605 Q705)

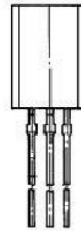
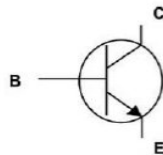

- 1. EMITTER
- 2. COLLECTOR
- 3. BASE

**12. SA1986R (MAIN: Q335 Q336 Q439 Q440
SURROUND: Q519 Q619 Q719)
2SC5358-R (MAIN: Q333 Q334 Q437 Q438
SURROUND: Q518 Q618 Q718)**

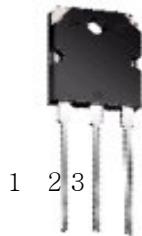

- 1. BASE
- 2. COLLECTOR
- 3. EMITTOR

13. LM19CIZ 2.4V TO-92
 (SUB: Q4011 MAIN: IC233)

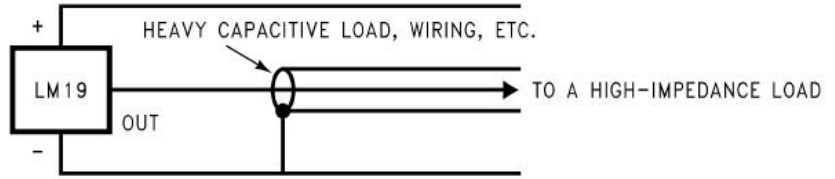
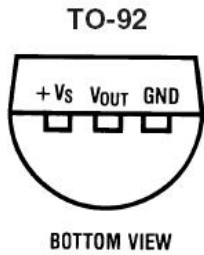

•OTHERS

1. FL HCA-18-BT-19GINK (FRONT : DP3501)

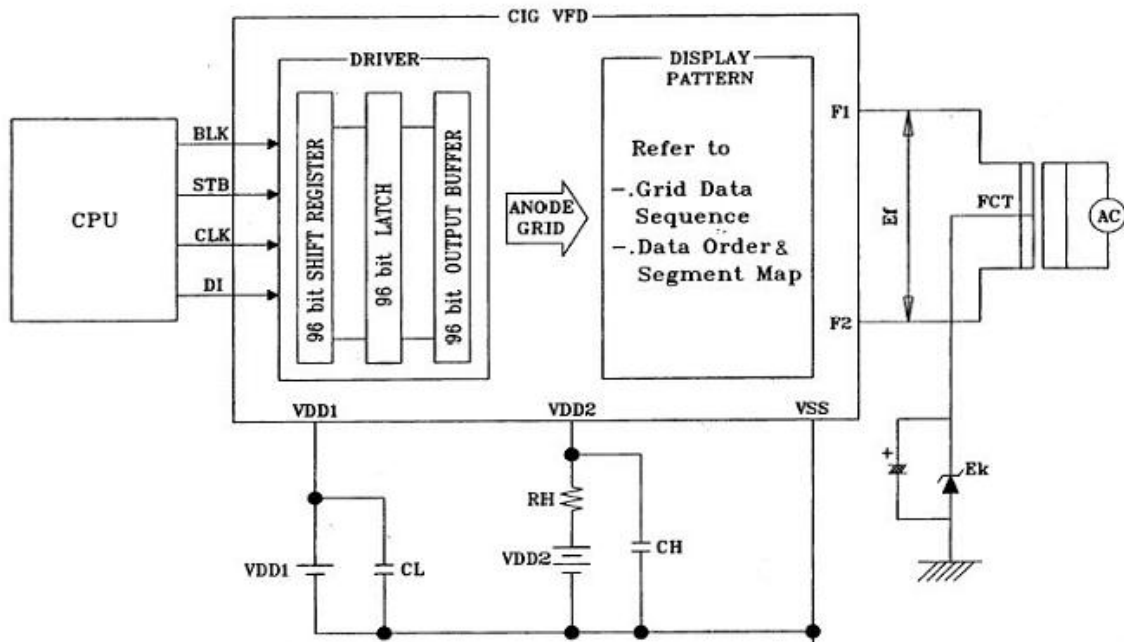

**** NOTE ****
 RH: Current limit resistor for protecting IC.
 CH,CL: Low pass filter for noise filtering.
 RH: 22Ω, CH: 0.1 μF, CL: 0.1 μF
 FCT: Filament is center-tab grounded.

3. OPTICAL RX YKC22-0873V (DSP: JA4002~JA4004)

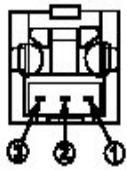

Pin connection

- 1. GND
- 2. Vcc
- 3. Input

Fiber optic connector insertion side

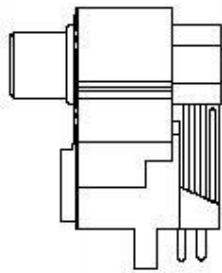
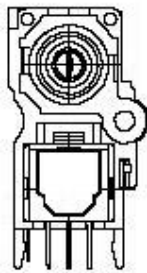
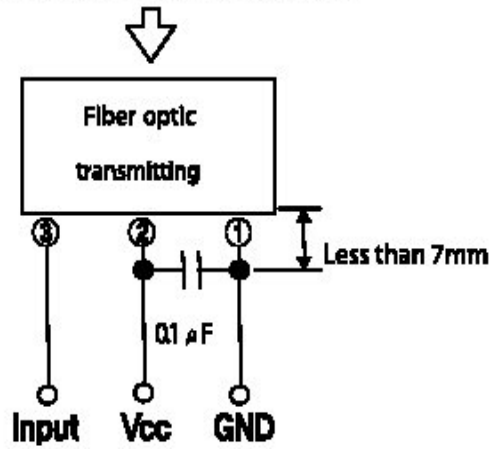

4. TORX177L (FRONT: NA3504)

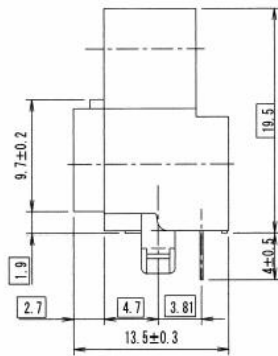
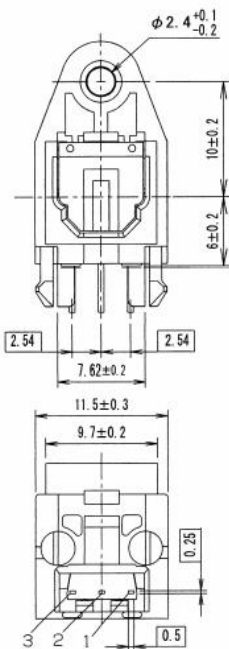

Shutter Color : Black

Pin Connection

- 1. Output
- 2. GND
- 3. Vcc

Fiber optic connector insertion side

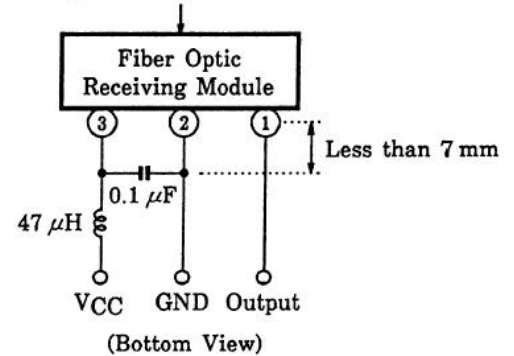

5. KSM603TE2E (FRONT: RM3501)

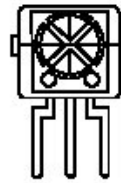

PIN NO.	
①	ROUT
②	GND
③	Vcc

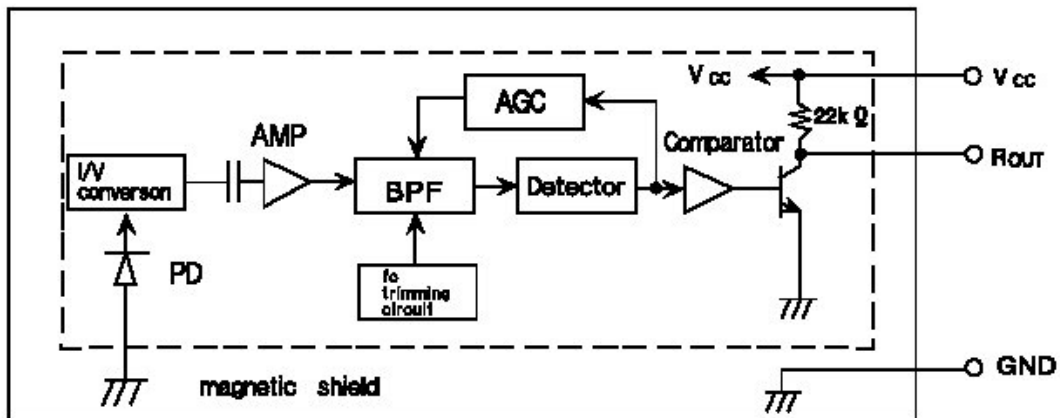

6. LP-200TL (FRONT: RM3502)

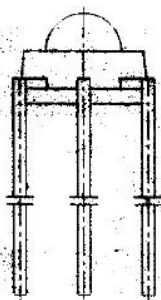
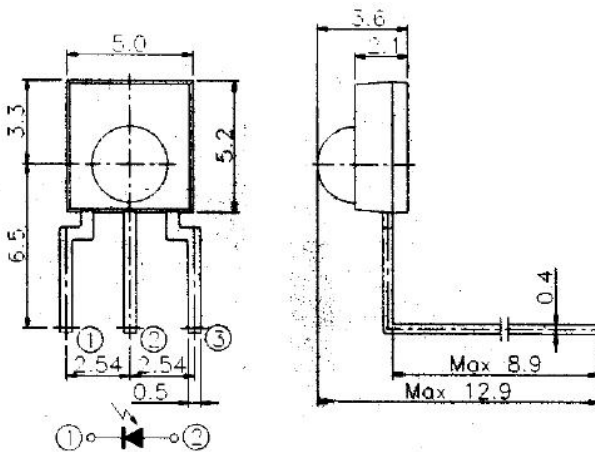

1. Pin Config.
 - ① Cathode
 - ② Anode
 - ③ No connect
2. G.T : ± 0.2

AVR 7550HD

harman/kardon

REVISION RECORD			
LTR	ECO NO:	APPROVED:	DATE:

POWER REG B'D

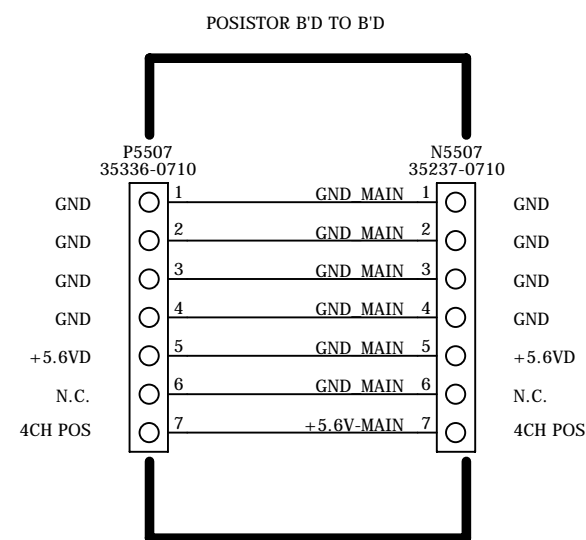
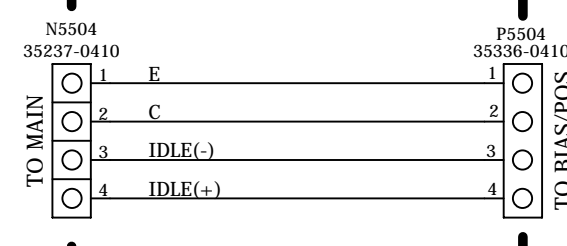
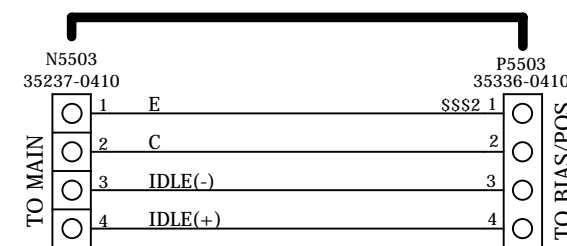
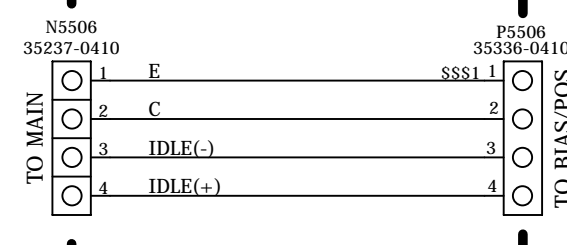
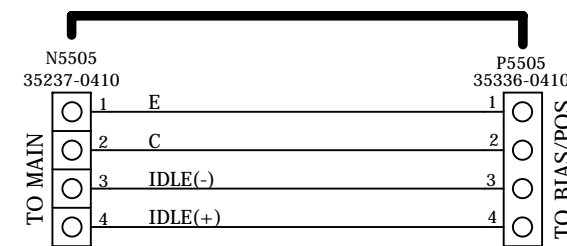
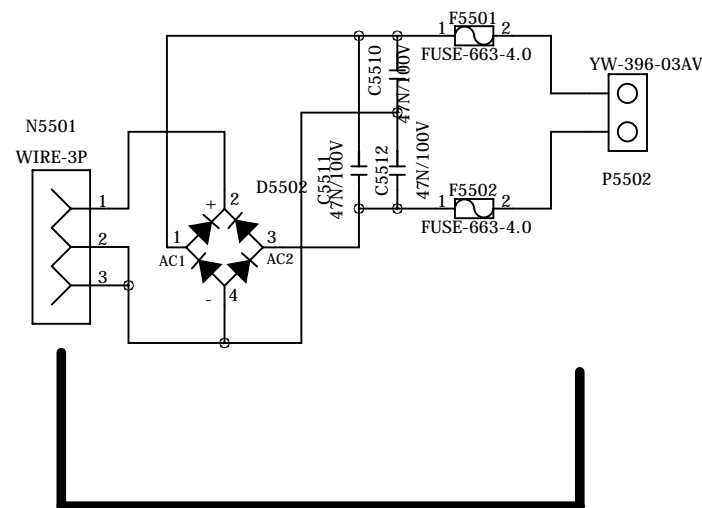
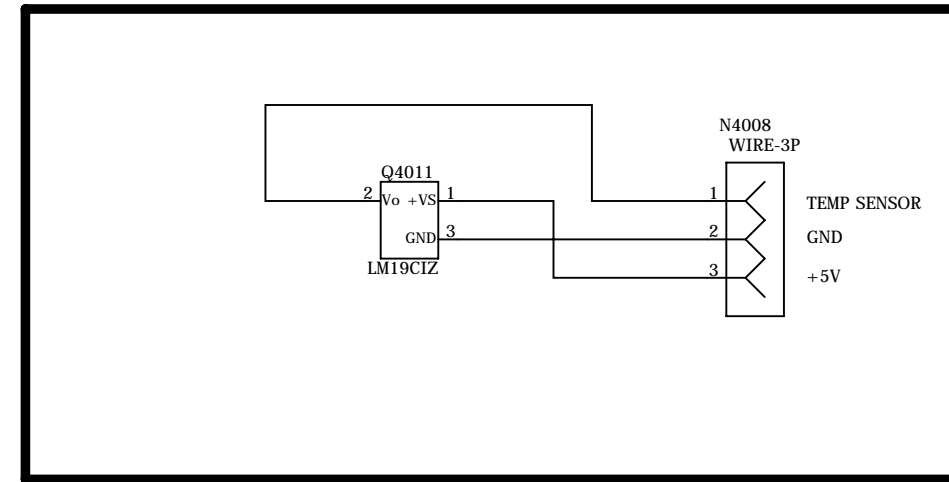
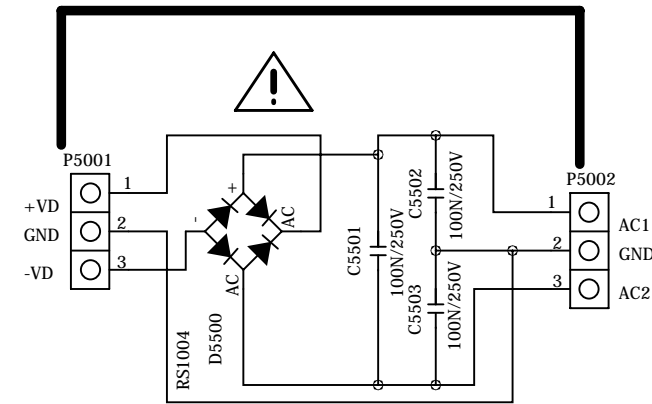

PCB PART-CODE

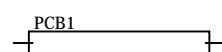

COMPANY: A/V RECEIVER			
TITLE: HK AVR7550HD/AVR760/AVR660			
CODE:	SIZE: A2	DRAWING NO:	REV: MP
SCALE: 1		SHEET: 1 OF	

DRAWN: J.S.CHOI	DATED: 2009.04.13
CHECKED: J.S.CHOI	DATED:
QUALITY CONTROL:	DATED:
RELEASED:	DATED:

Schematic Diagram

harman/kardon

harman/kardon

FROM HDMI B'D AVR7550HD/760 VIDEO 1/2

REVISION RECORD		
NO.	Date	Contents

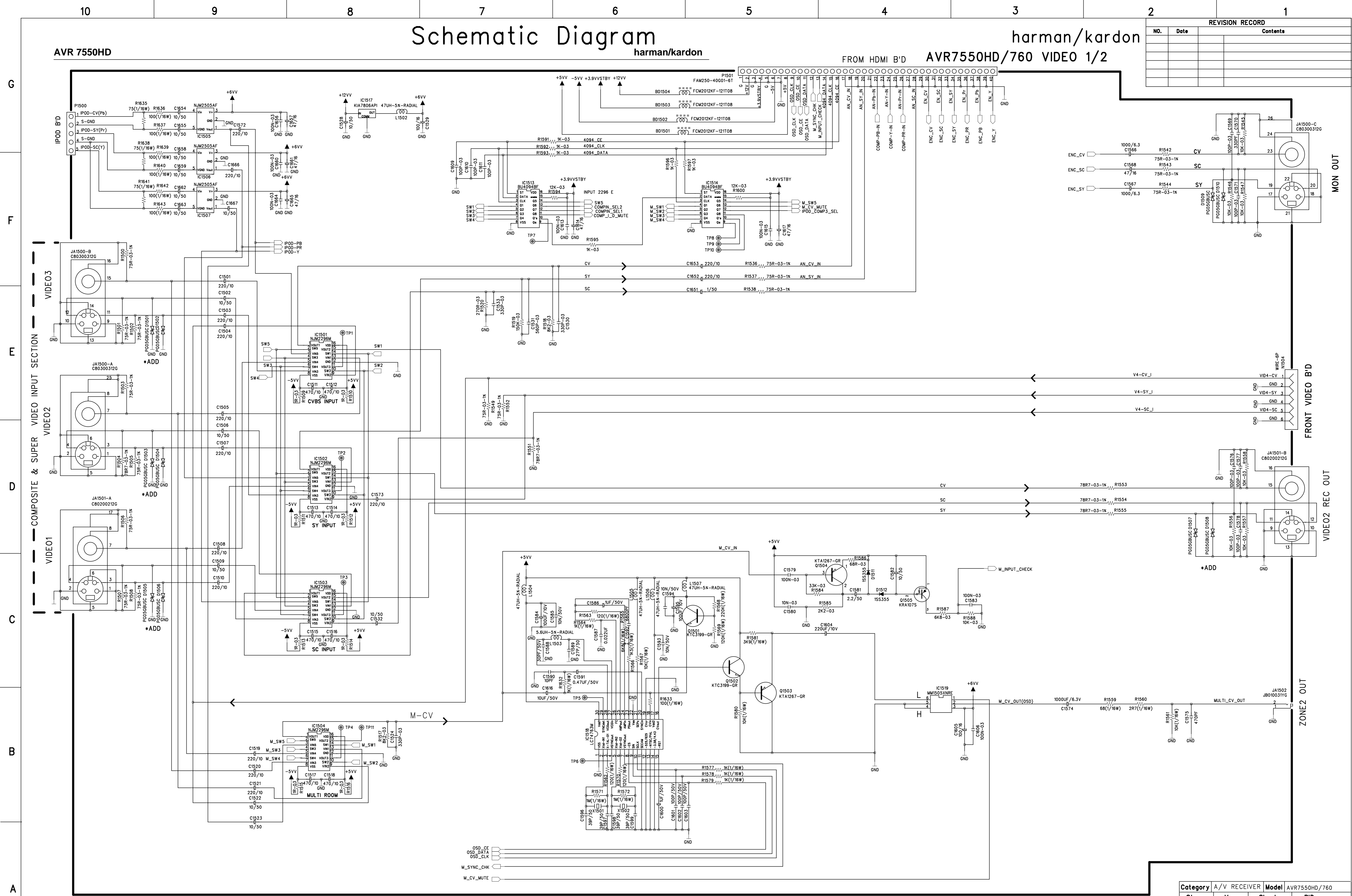

*** THE UNIT OF RESISTANCE IS OHM.
 K=1000 OHM, M=10000 OHM
 *** THE UNIT OF CAPACITANCE IS MICROFARAD (UF)
 PF=10⁻¹²
 *** THIS SCHEMATIC DIAGRAM MAY MODIFIED AT ANYTIME WITH THE IMPROVEMENT OF PERFORMANCE.

PCB1 2

Category	A/V RECEIVER	Model	AVR7550HD/760
Stage	Ver.	Sheet	B'D name
MP	V4.10	1 / 2	VIDEO
Draw	Approved	Date	Drawing No
J G EOM		APR.13.2009	

Schematic Diagram

AVR 7550HD

harman/kardon

harman/kardon
AVR7550HD/760/660 VIDEO 2/2

REVISION RECORD		
NO.	Date	Contents

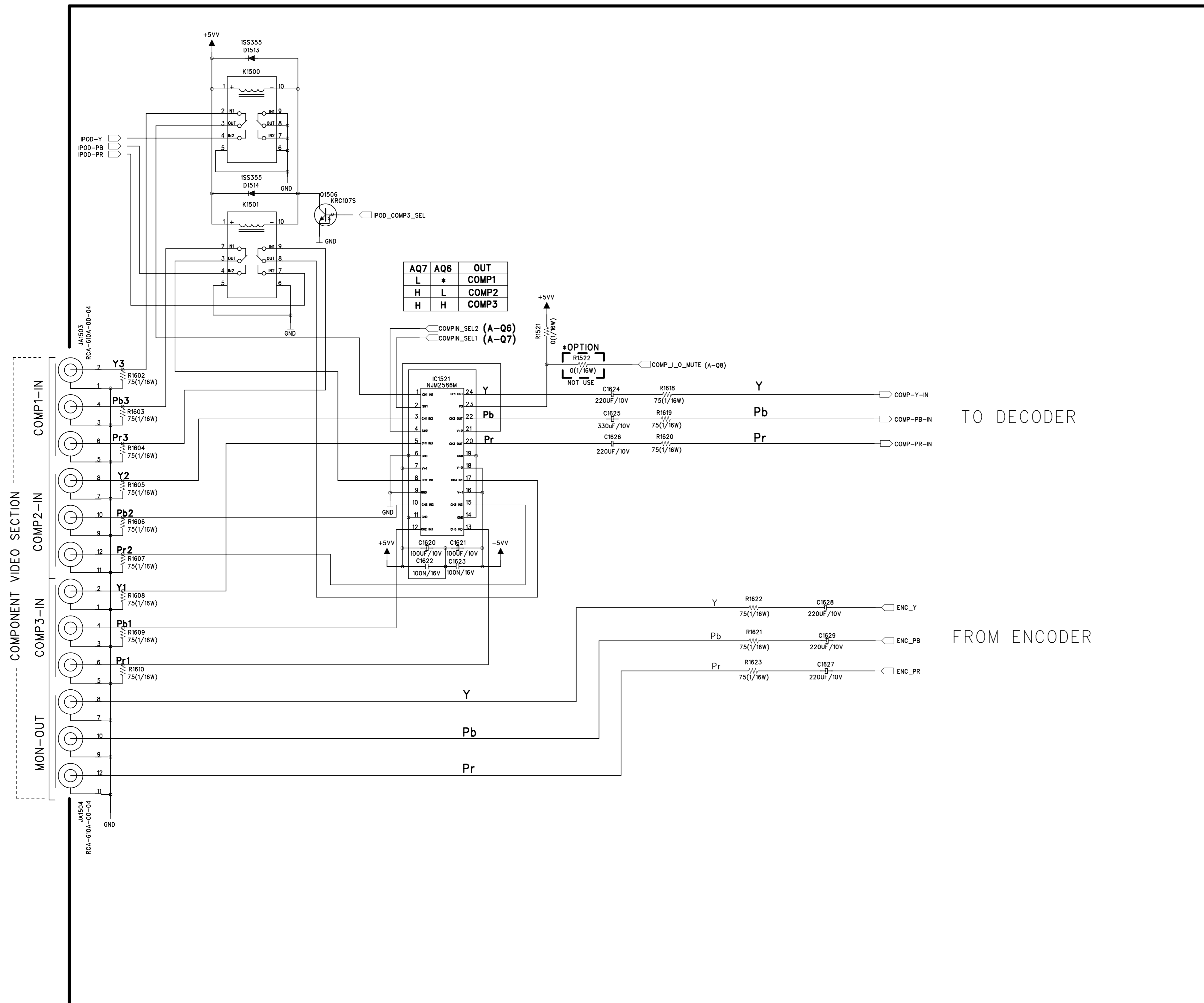

TO DECODER

FROM ENCODER

*** THE UNIT OF RESISTANCE IS OHM.
 K=1000 OHM, M=10000 OHM
 *** THE UNIT OF CAPACITANCE IS MICROFARAD (UF)
 PF=10^-12
 *** THIS SCHEMATIC DIAGRAM MAY MODIFIED AT ANYTIME WITH THE
 IMPROVEMENT OF PERFORMANCE.

Category	A/V RECEIVER	Model	AVR7550HD/760
Stage	Ver.	Sheet	B'D name
MP	V4.10	2 / 2	VIDEO
Draw	Approved	Date	Drawing No
		APR.13.2009	

SCHEMATIC DIAGRAM AVR7550HD/760EU SURROUND AMP B'D

AVR 7550HD

harman/kardon

REVISION RECORD	
NO.	Contents

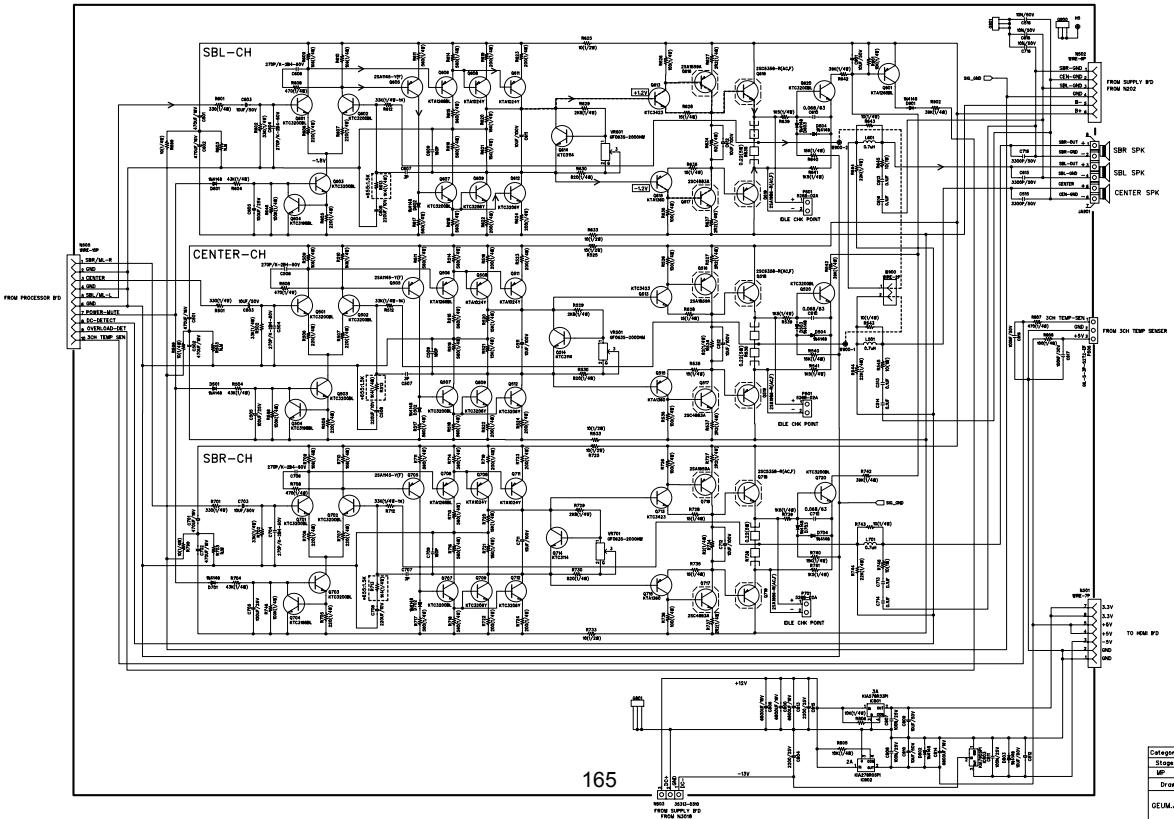

Category	A/V RECEIVER	Model	AVR7550HD/760EU
Stage	0.0	Sheet	1 / 1
MP			SURROUND
Draw	Approved	Date	2008.04.09
DELM.J.G			Drawing No.

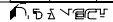

REVISION RECORD		
NO.	Date	Contents

AVR 7550HD

harman/kardon

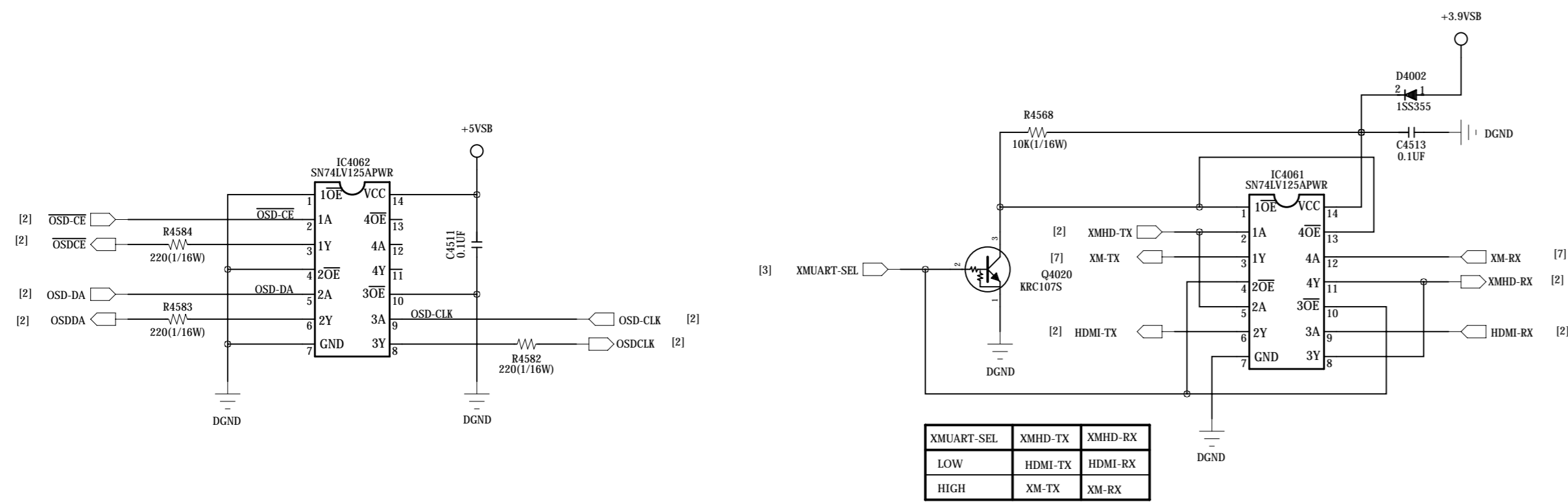

XMUART-SEL	XMHD-TX	XMHD-RX
LOW	HDMI-TX	HDMI-RX
HIGH	XM-TX	XM-RX

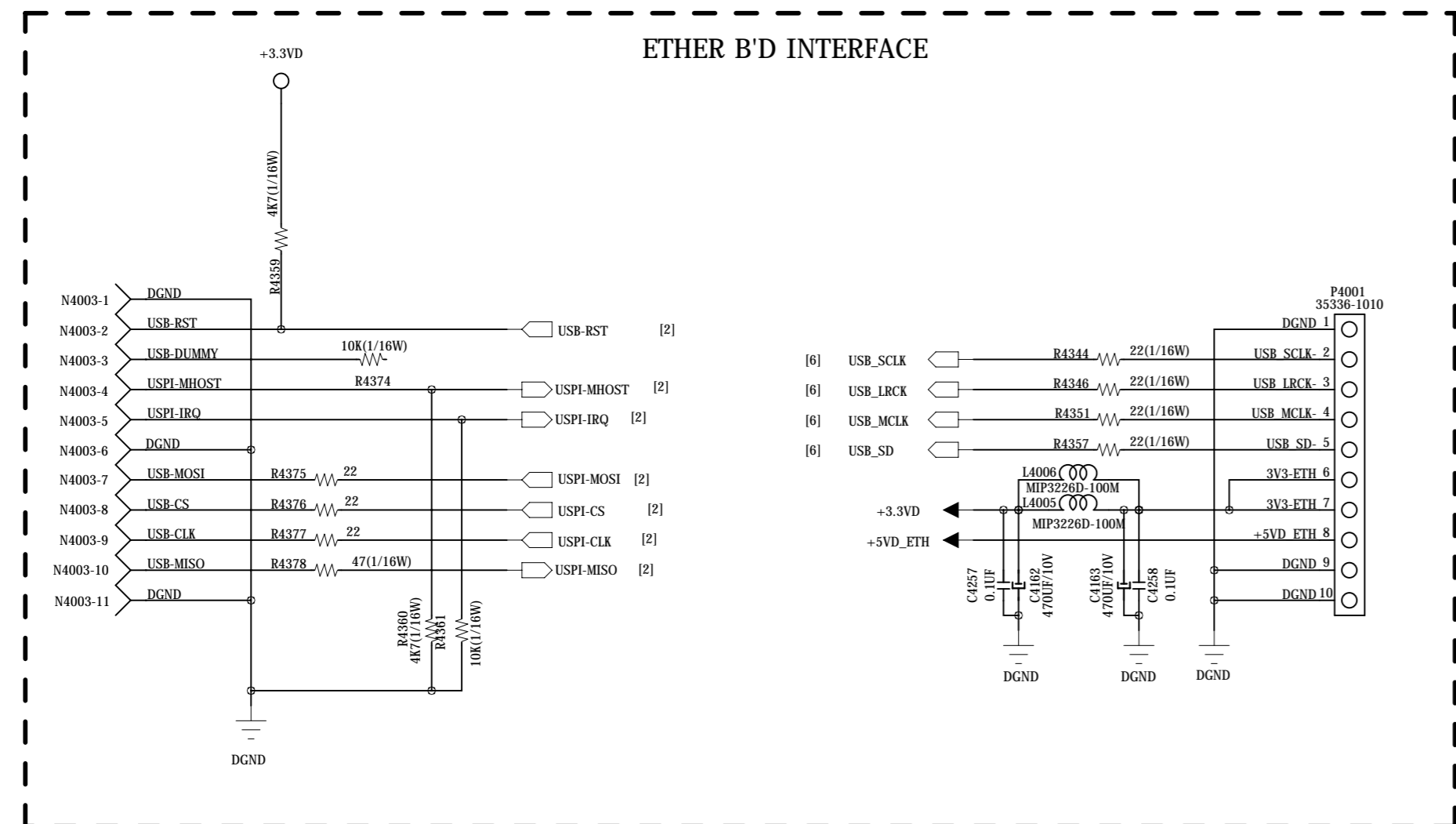
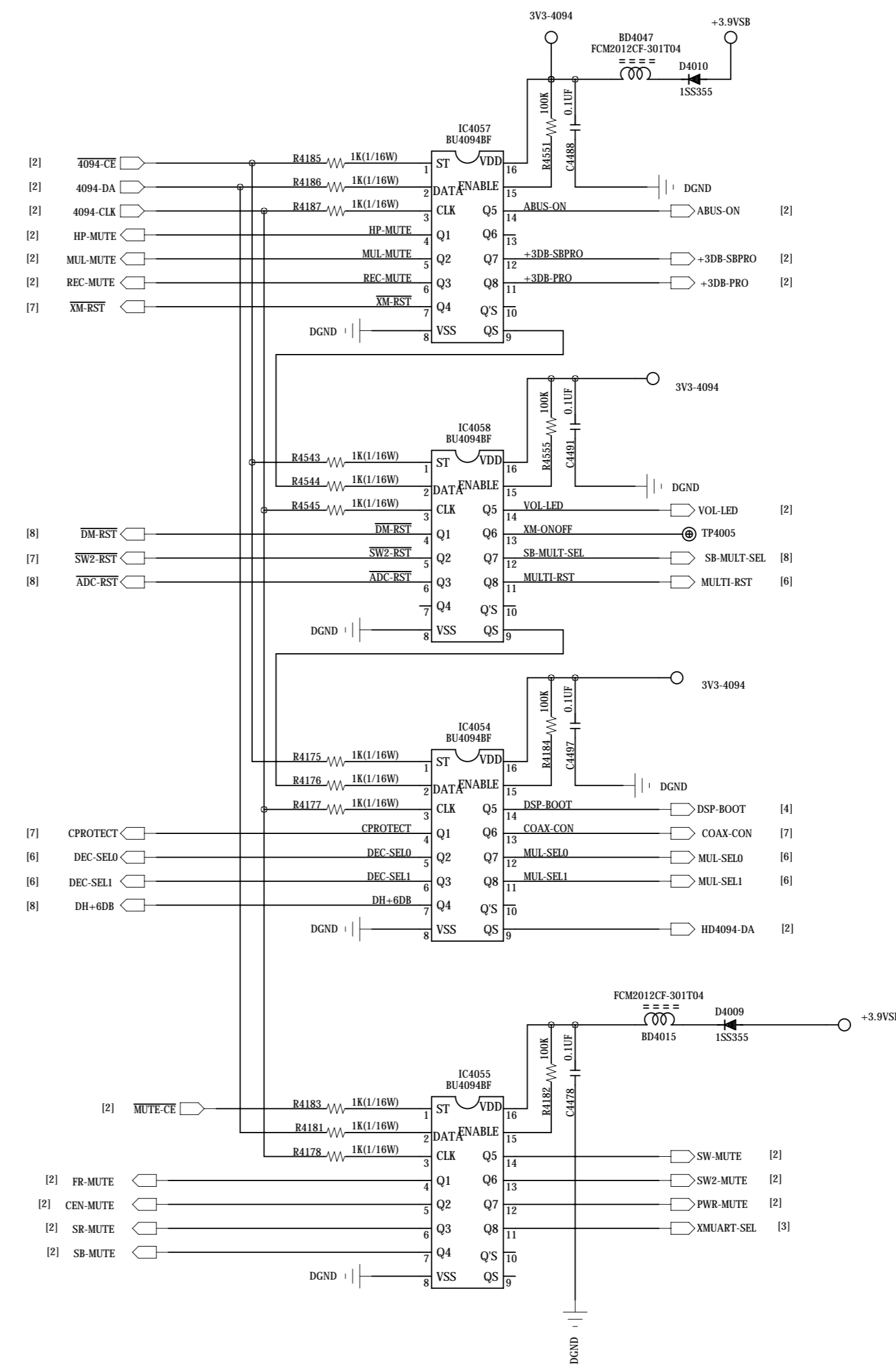

Category	A/V RECEIVER	Model	AVR7550HD/760/660
Stage	v01	Sheet	B'D name
MP		3 / 9	DSP
Draw	Approved	Date	Drawing No
W.D. KIM		2009.04.13	

AVR 7550HD

harman/kardon

REVISION RECORD		
NO.	Date	Contents

G
F
E
D
C
B
A

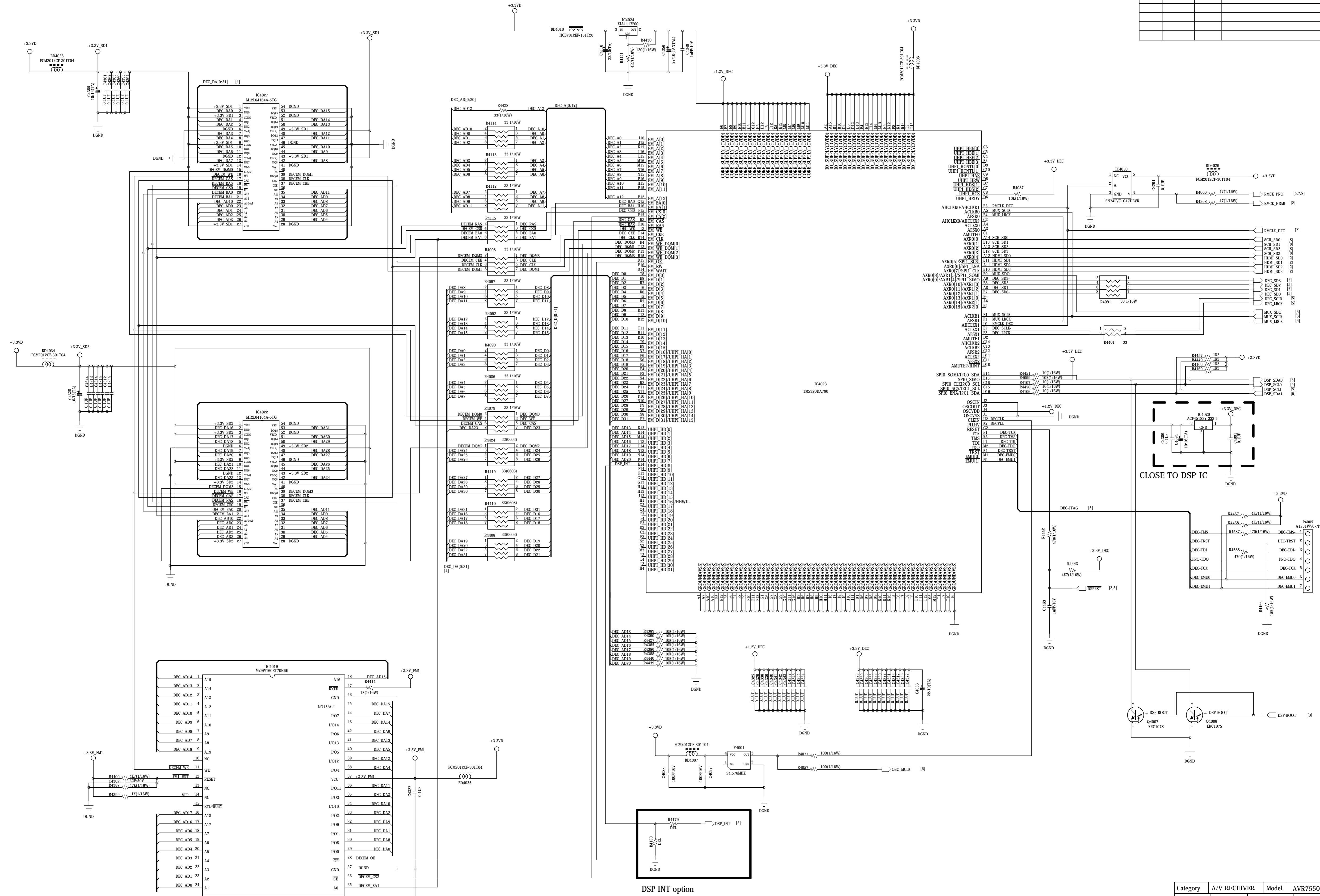

DSP INT option

CLOSE TO DSP IC

Category	A/V RECEIVER	Model	AVR7550HD/760/660
Stage	Ver.	Sheet	B'D name
MP	v01	4 / 9	DSP
Draw	Approved	Date	Drawing No
W.D. KIM		2009.04.13	

AVR 7550HD

harman/kardon

REVISION RECORD		
NO.	Date	Contents

G
F
E
D
C
B
A

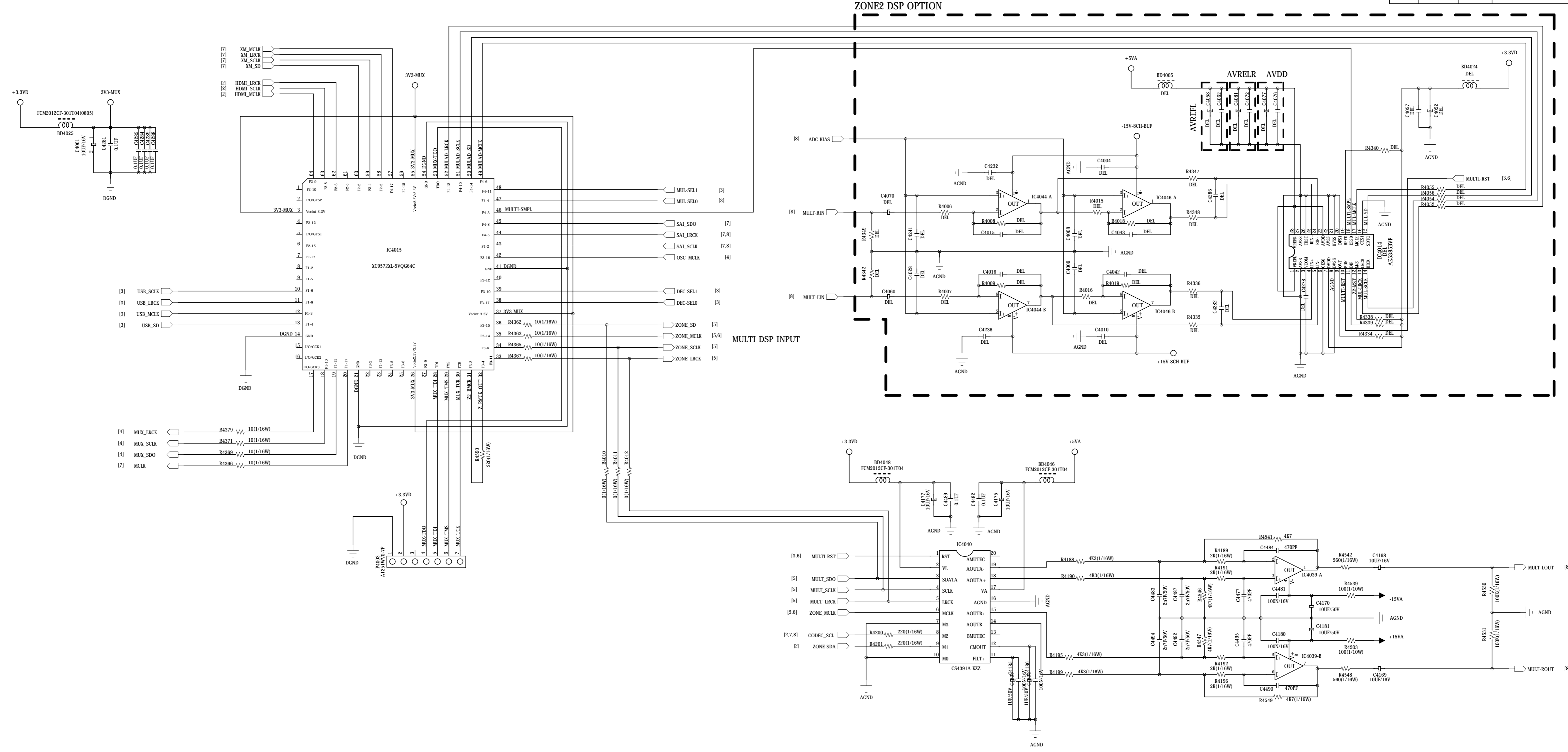

Category	A/V RECEIVER	Model	AVR7550HD/760/660
Stage	Ver.	Sheet	B'D name
MP	v01	6 / 9	DSP
Draw	Approved	Date	Drawing No
W.D. KIM		2009.04.13	

AVR 7550HD

harman/kardon

REVISION RECORD		
NO.	Date	Contents

G

F

E

D

C

B

A

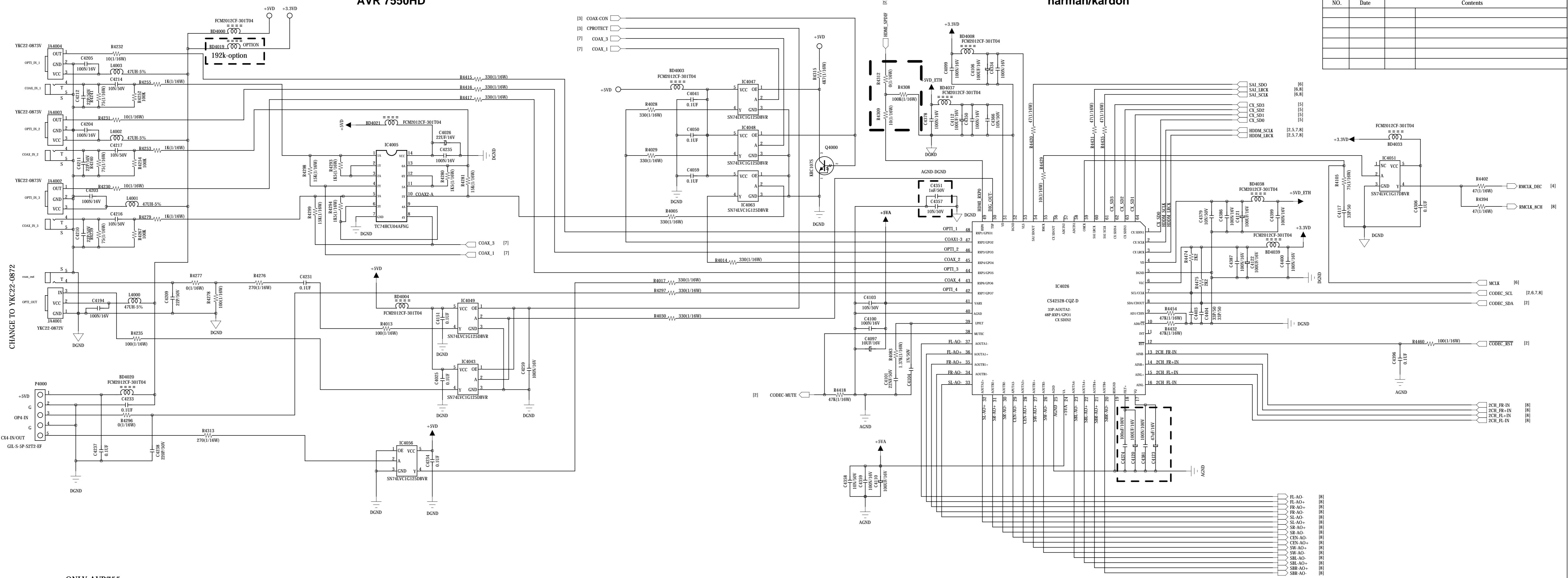

ONLY AVR755

US ONLY

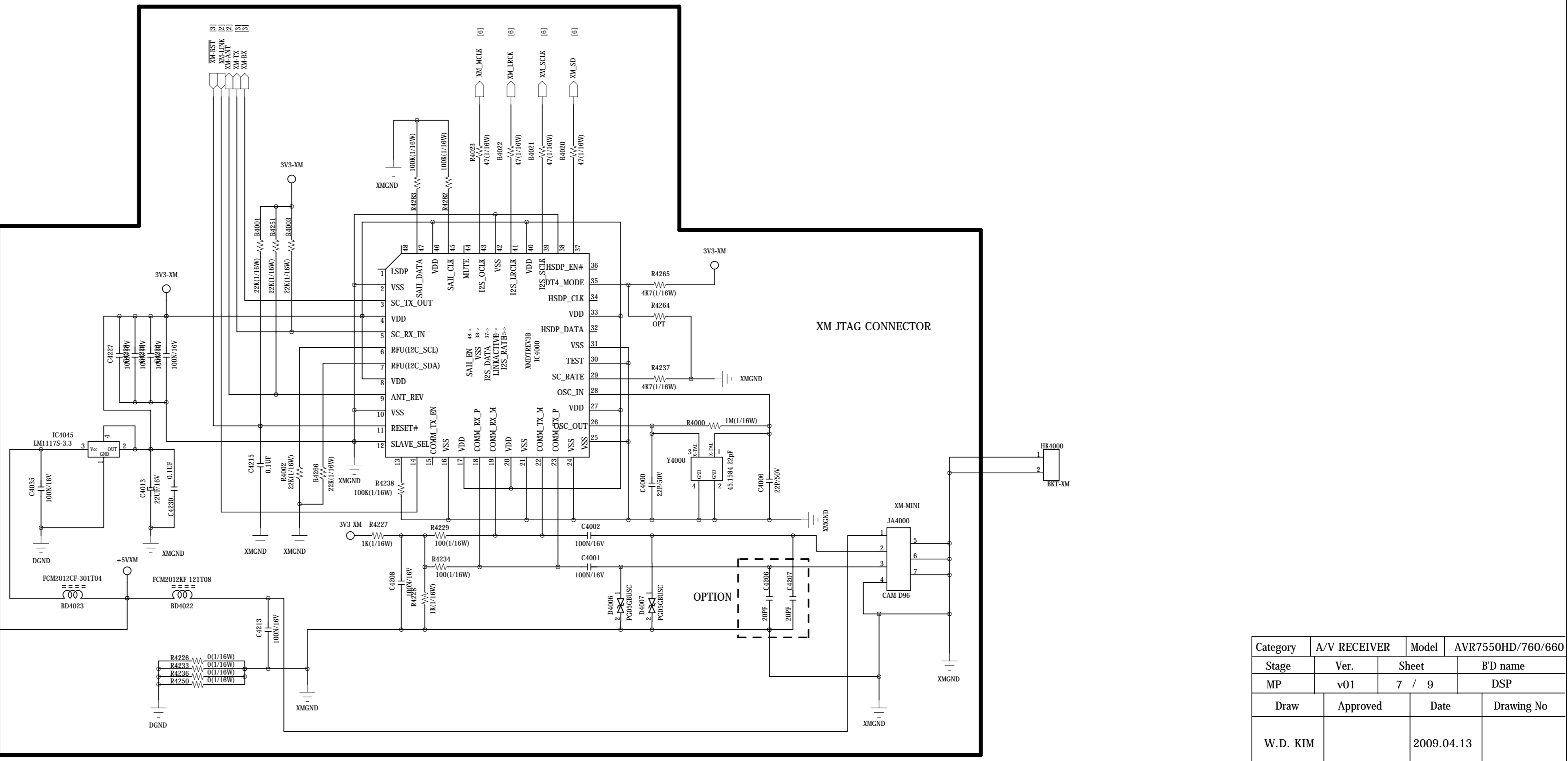
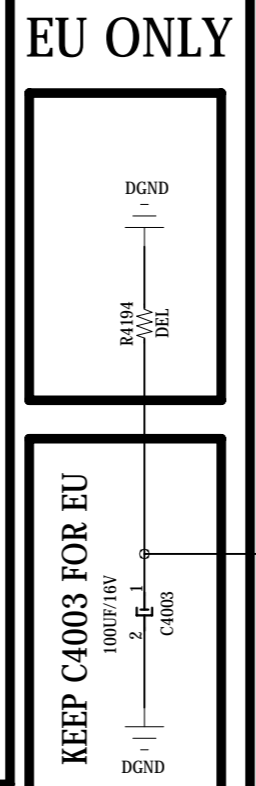
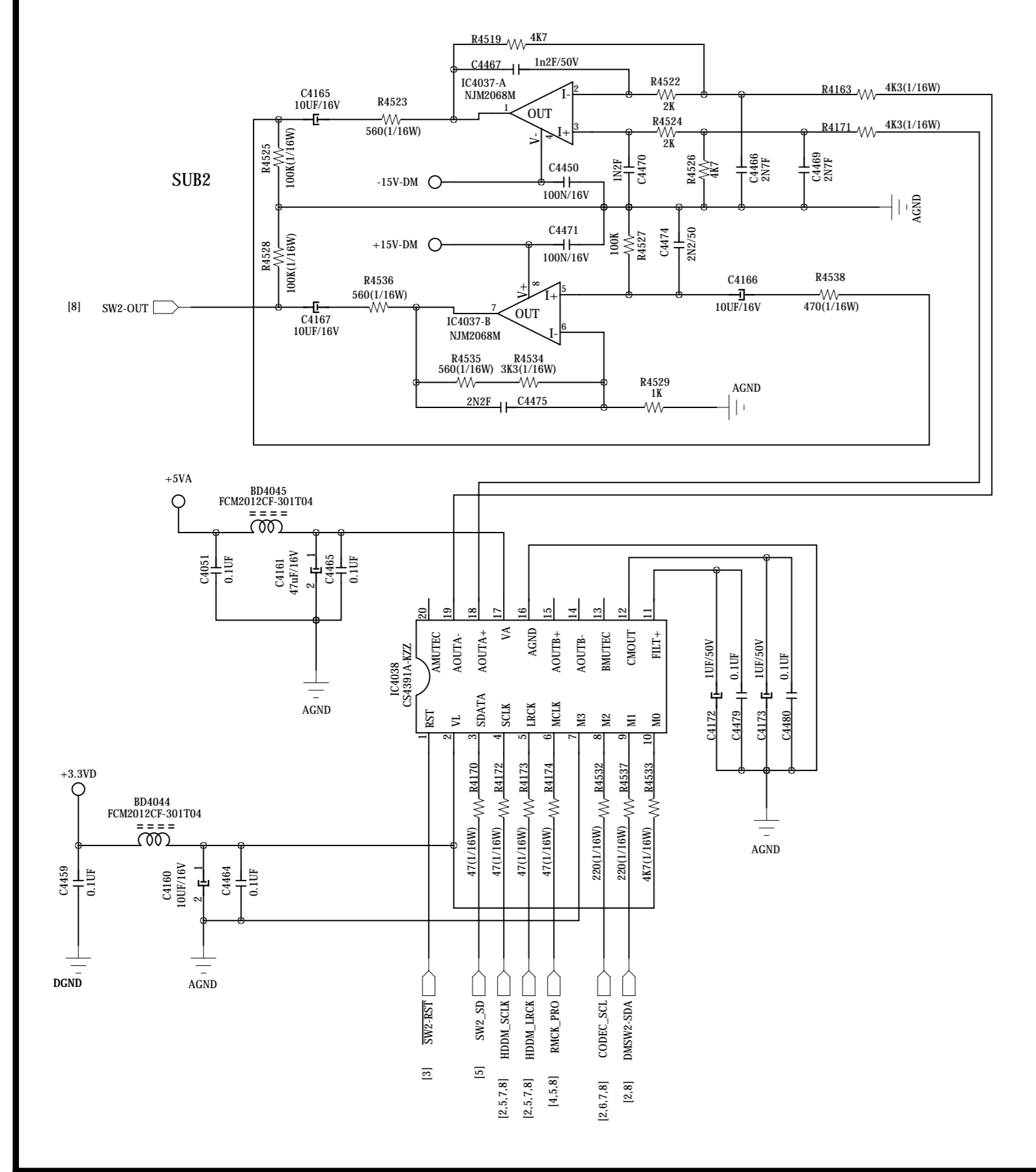

Category	A/V RECEIVER	Model	AVR7550HD/760/660
Stage	Ver.	Sheet	B'D name
MP	v01	7 / 9	DSP
Draw	Approved	Date	Drawing No
W.D. KIM		2009.04.13	

AVR 7550HD harman/kardon

REVISION RECORD		
NO.	Date	Contents

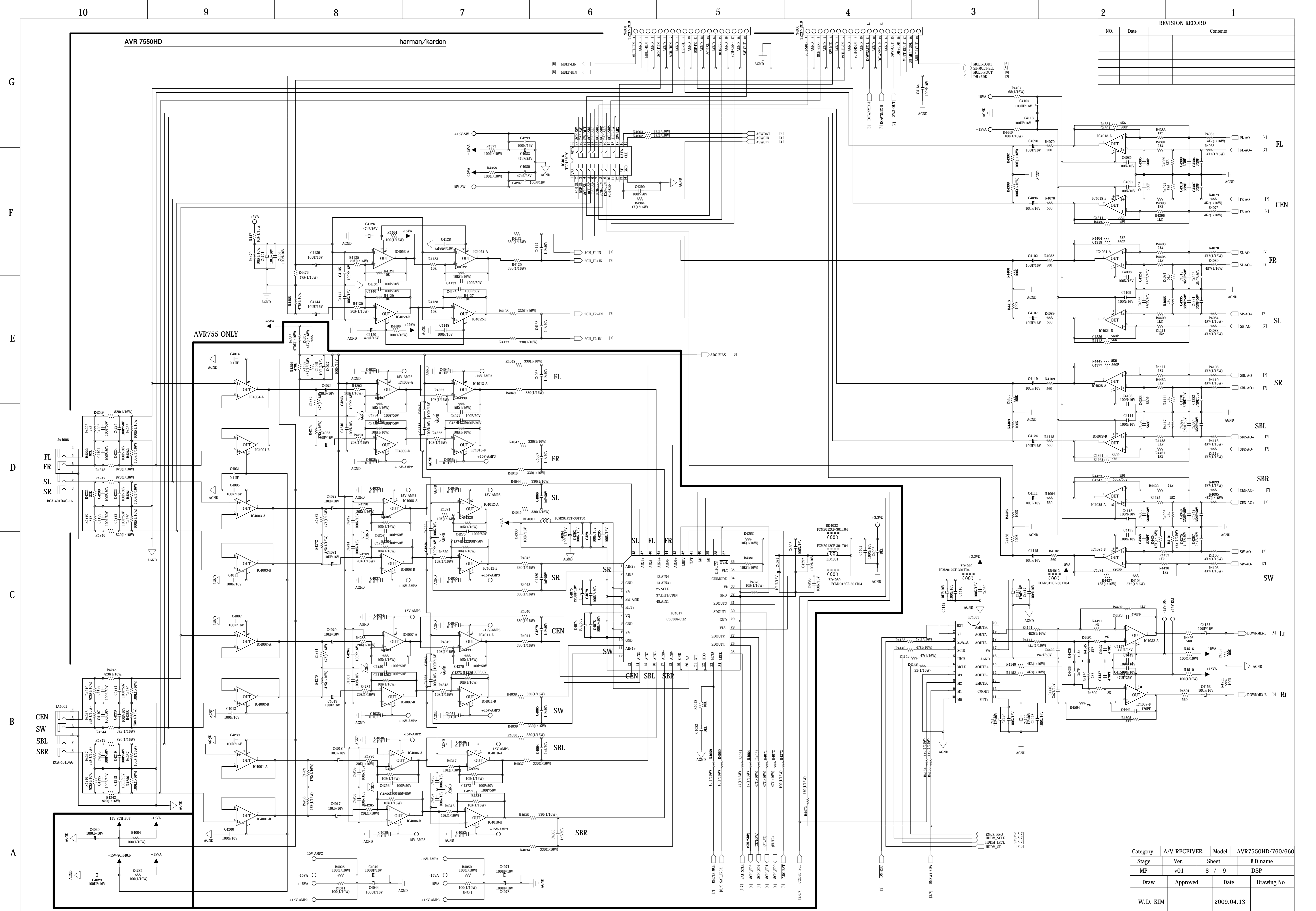

Category	A/V RECEIVER	Model	AVR7550HD/760/660
Stage	Ver.	Sheet	B'D name
MP	v01	8 / 9	DSP
Draw	Approved	Date	Drawing No
W.D. KIM		2009.04.13	

AVR 7550HD

harman/kardon

REVISION RECORD		
NO.	Date	Contents

UART driver will be made as an extension board for debugging.

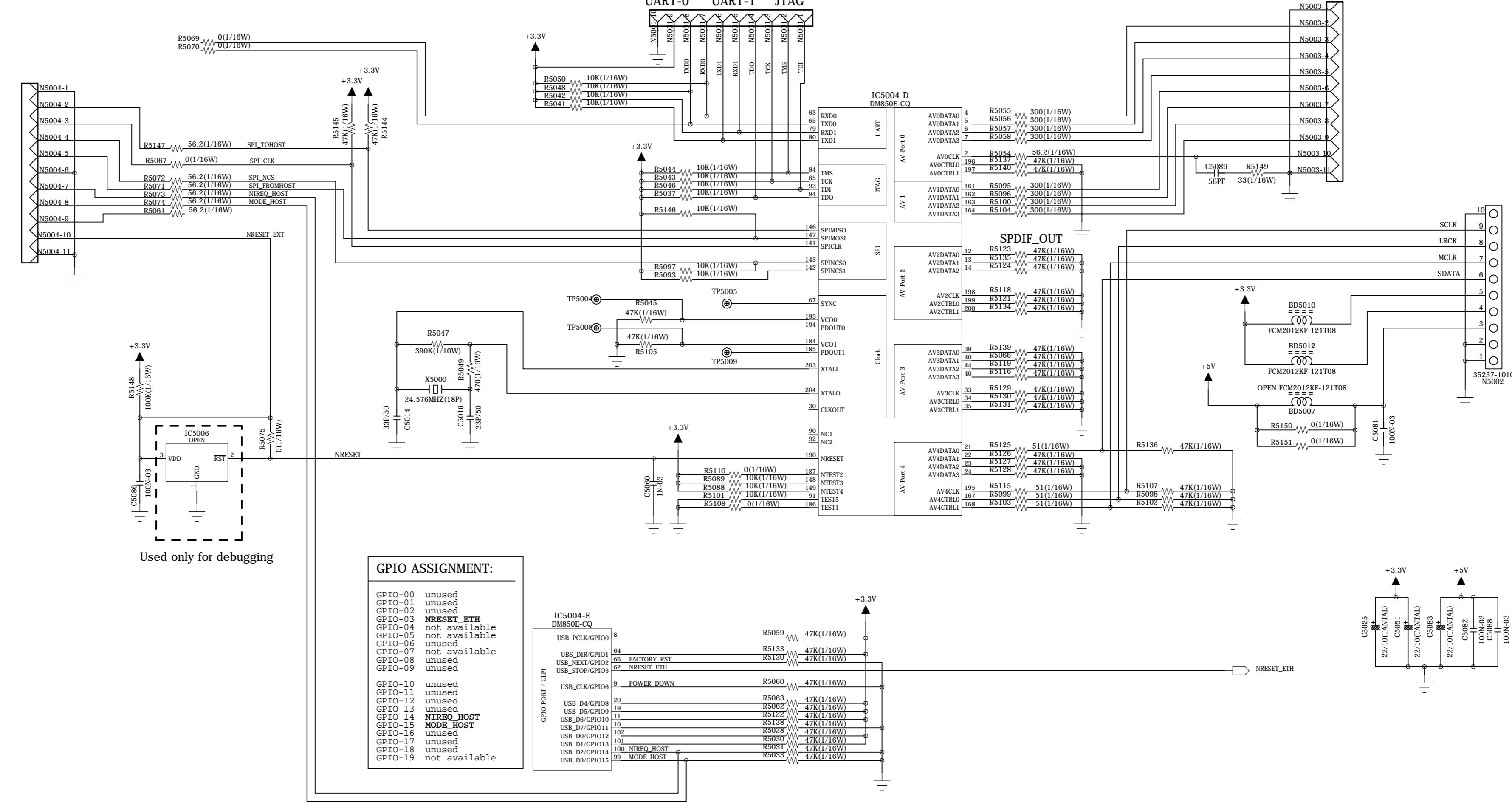

Used only for debugging

GPIO ASSIGNMENT:

GPIO-00	unused
GPIO-01	unused
GPIO-02	unused
GPIO-03	NRESET_ETH
GPIO-04	not available
GPIO-05	unused
GPIO-06	unused
GPIO-07	not available
GPIO-08	unused
GPIO-09	unused
GPIO-10	unused
GPIO-11	unused
GPIO-12	unused
GPIO-13	unused
GPIO-14	MODE_HOST
GPIO-15	MODE_HOST
GPIO-16	unused
GPIO-17	unused
GPIO-18	unused
GPIO-19	not available

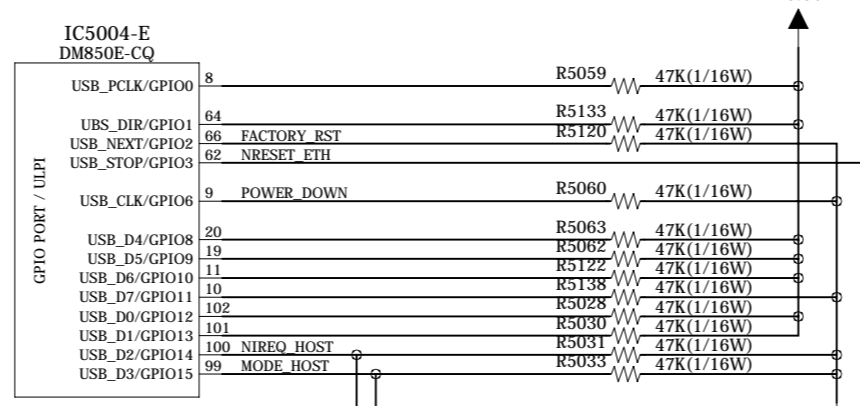

AUDIO

SDRAM PCB layout specifications:

- all signals routed with 4mil trace width
- A13...A18 as short as possible
- T-junctions as short as possible

Type 1) examples:
 - W2925643B
 - S29GL044McxTF1R3/4
 - S29GL032AcxTP1R3...R4

Type 2) examples:
 - M291641W
 - S29GL044McxTF1R6/7
 - S29F330C3B/P
 - AM29LV641DH90REF

	Type 1)	Type 2)
R248 (p9; A19):	OR	NP
R249 (p9; A21):	NP	OR
R254 (p13):	NP	OR
R253 (p15; A19):	NP	OR
R271 (p13; A21):	NP	OR

PCB CUP12039Z

Category	A/V RECEIVER	Model	HK AVR7550HD
Stage	Ver.	Sheet	B'D name
MP	1.0		ETHER
Draw	Approved	Date	Drawing No
GS / SK		2009. 04. 13	1 / 2

AVR 7550HD

Schematic Diagram

harman/kardon

harman/kardon
AVR7550HD/760/660 FRONT

REVISION RECORD		
NO.	Date	Contents

*** THE UNIT OF RESISTANCE IS OHM.
K=1000 OHM, M=1000 KOHM.
*** THE UNIT OF CAPACITANCE IS MICROFARAD (uF)
u=10⁻⁶ uF
*** THIS SCHEMATIC DIAGRAM MAY MODIFIED AT ANYTIME WITH THE IMPROVEMENT OF PERFORMANCE.

F
E
D
C
B
A

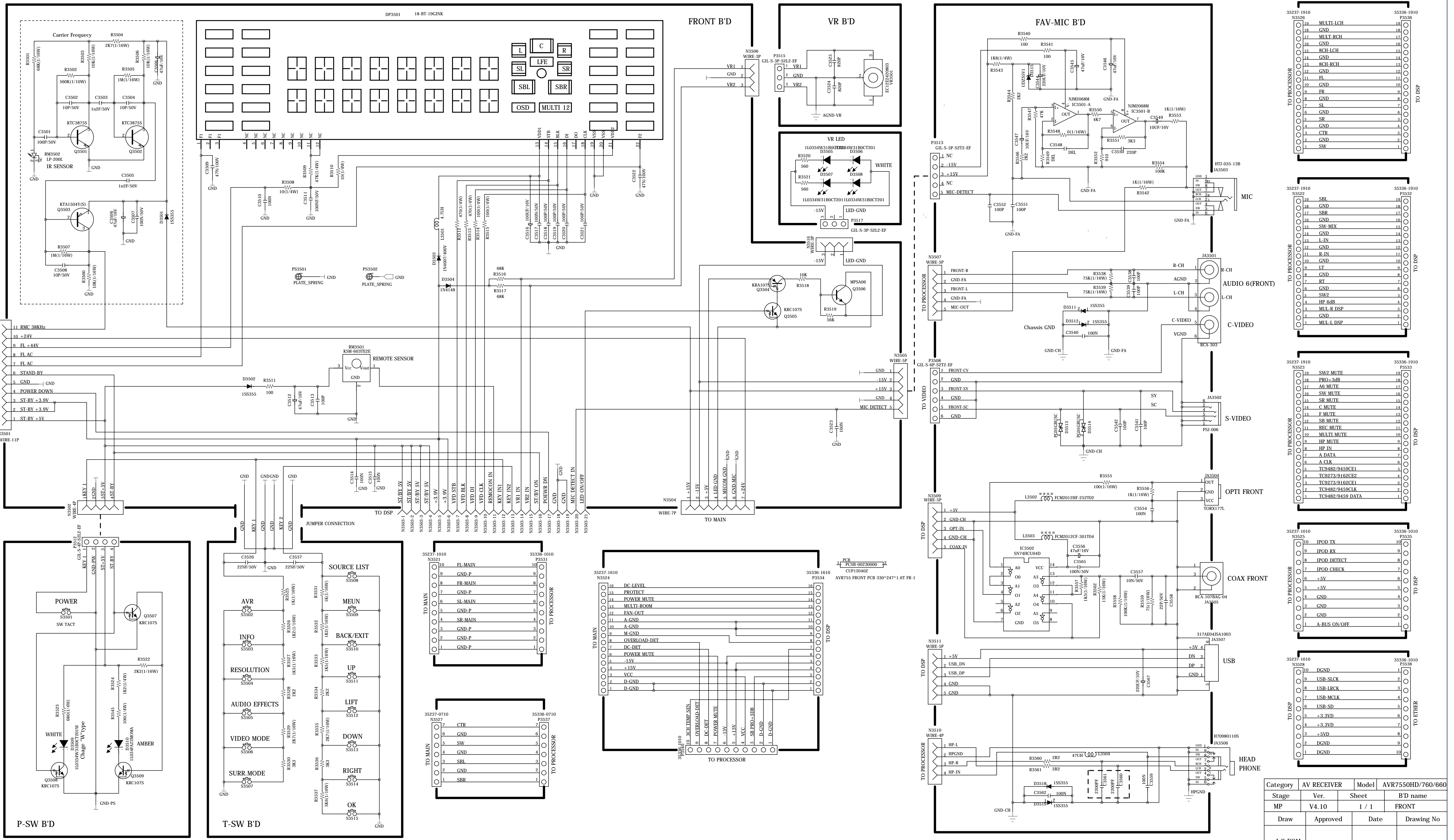

Category	AV RECEIVER	Model	AVR7550HD/760/660
Stage	Ver.	Sheet	B'D name
MP	V4.10	1 / 1	FRONT
Draw	Approved	Date	Drawing No
J G EOM		APR. 13. 2009	

AVR 7550HD

harman/kardon

REVISION RECORD		
NO.	Date	Contents

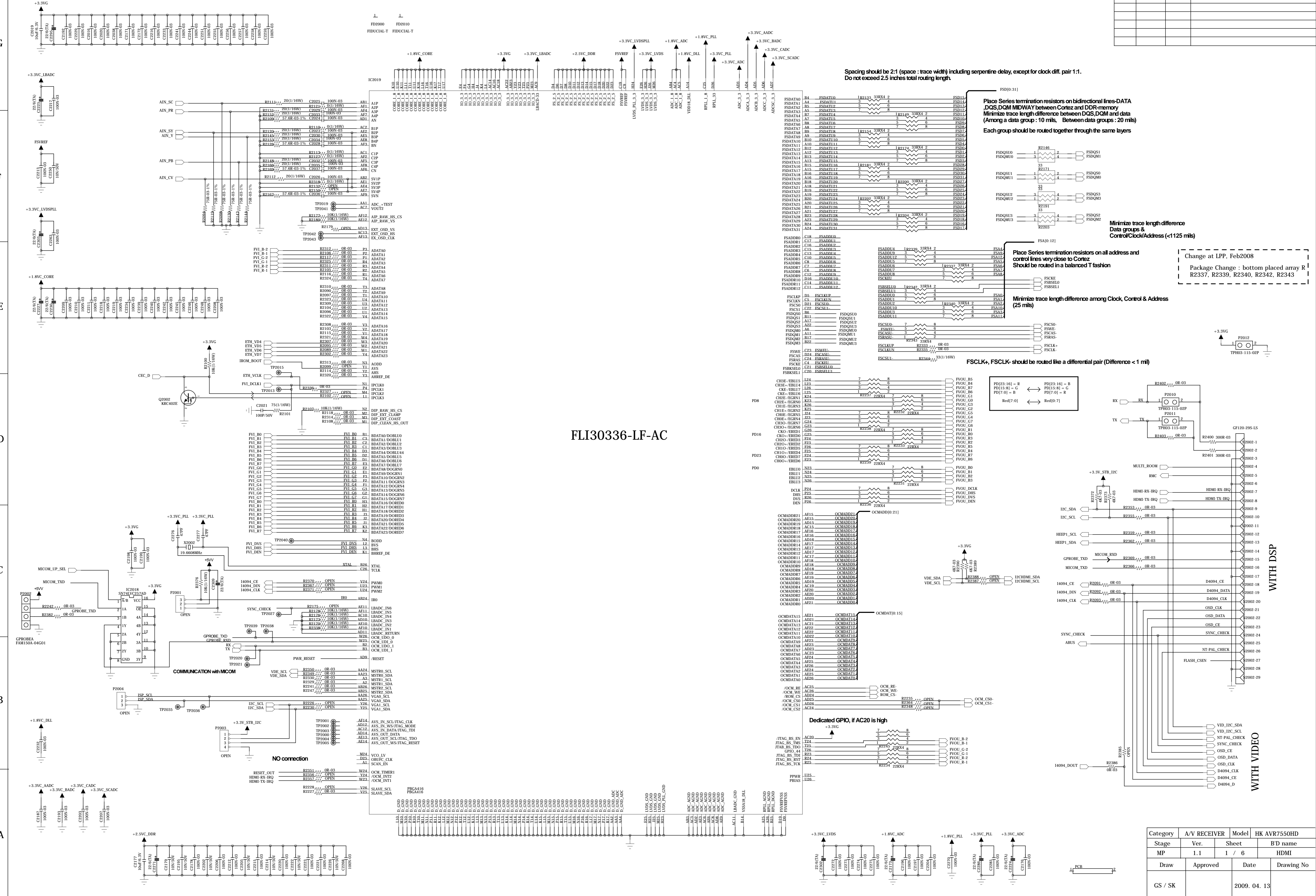

Spacing should be 2:1 (space : trace width) including serpentine delay, except for clock diff. pair 1:1. Do not exceed 2.5 inches total routing length.

Place Series termination resistors on bidirectional lines-DATA, DQS, DQM MIDWAY between Cortex and DDR-memory. Minimize trace length difference between DQS, DQM and data (Among a data group : 10 mils, Between data groups : 20 mils). Each group should be routed together through the same layers.

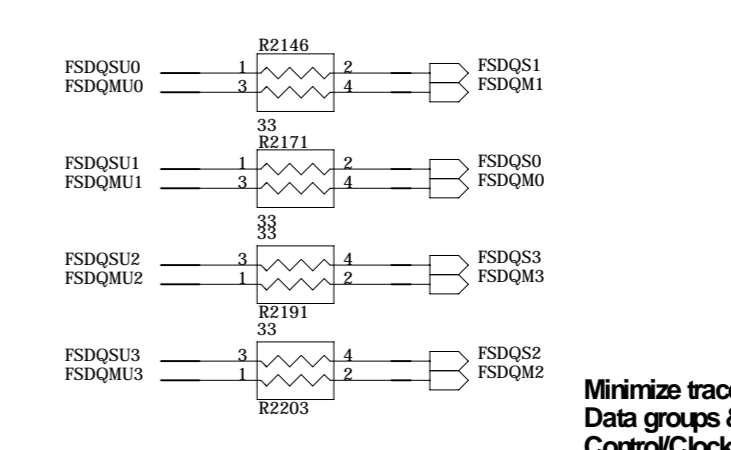

Minimize trace length difference Data groups & Control/Clock/Address (<125 mils)

Change at LPP, Feb2008
Package Change : bottom placed array R
R2337, R2339, R2340, R2342, R2343

Place Series termination resistors on all address and control lines very close to Cortex. Should be routed in a balanced T fashion.

Minimize trace length difference among Clock, Control & Address (25 mils)

FSCLK+, FSCLK- should be routed like a differential pair (Difference < 1 mil)

FLI30336-LF-AC

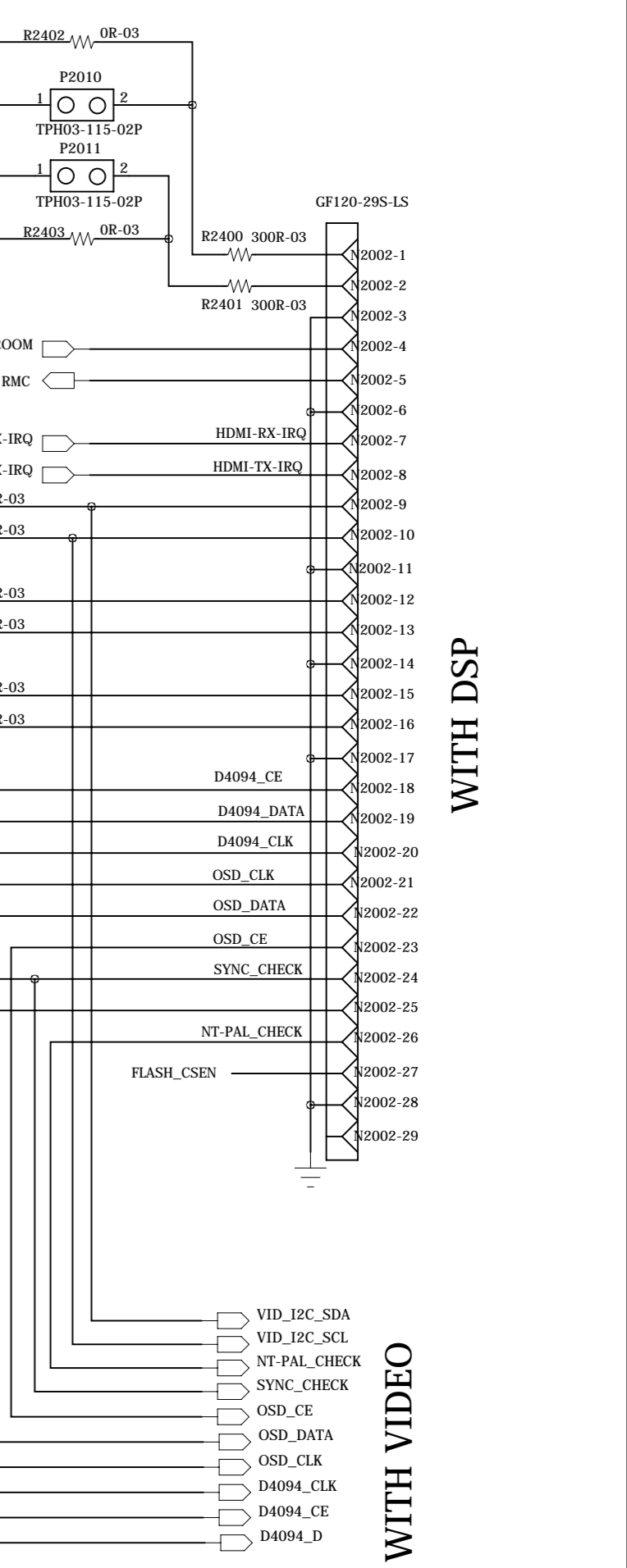

Dedicated GPIO, if AC20 is high

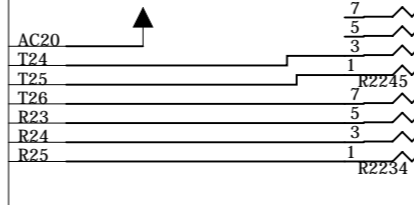

Category	A/V RECEIVER	Model	HK AVR7550HD
Stage	Ver.	Sheet	B'D name
MP	1.1	1 / 6	HDMI
Draw	Approved	Date	Drawing No
GS / SK		2009. 04. 13	

AVR 7550HD

harman/kardon

REVISION RECORD		
NO.	Date	Contents

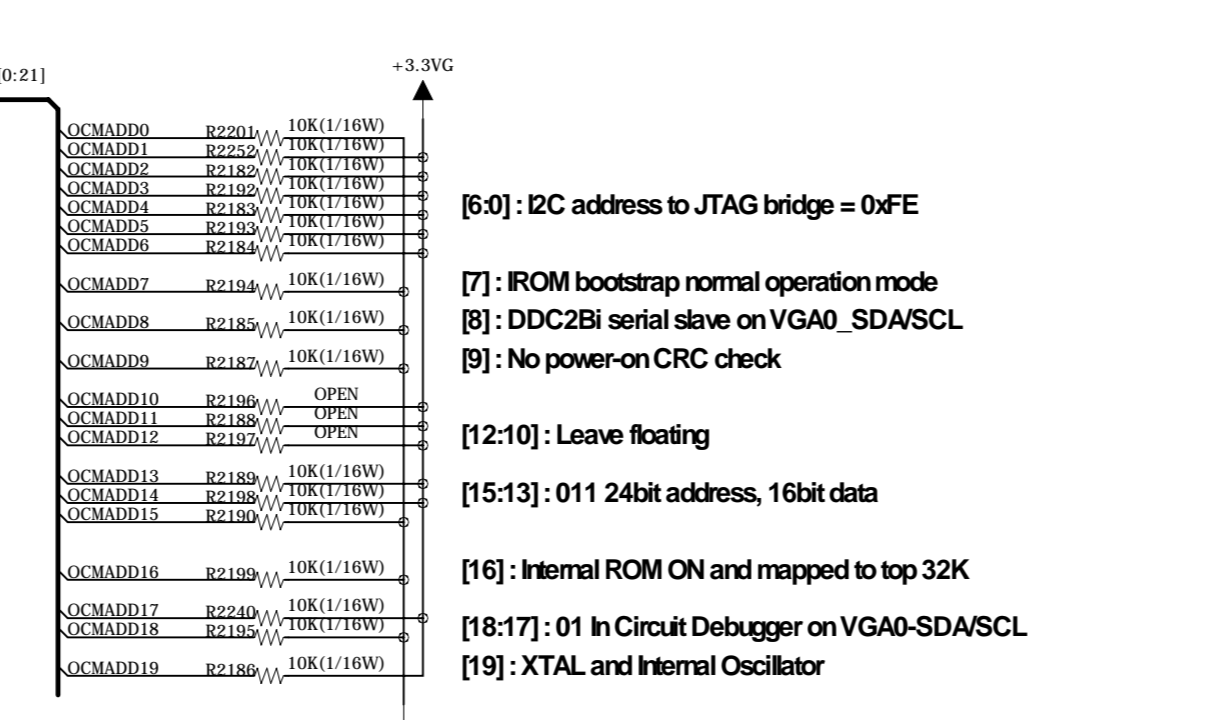
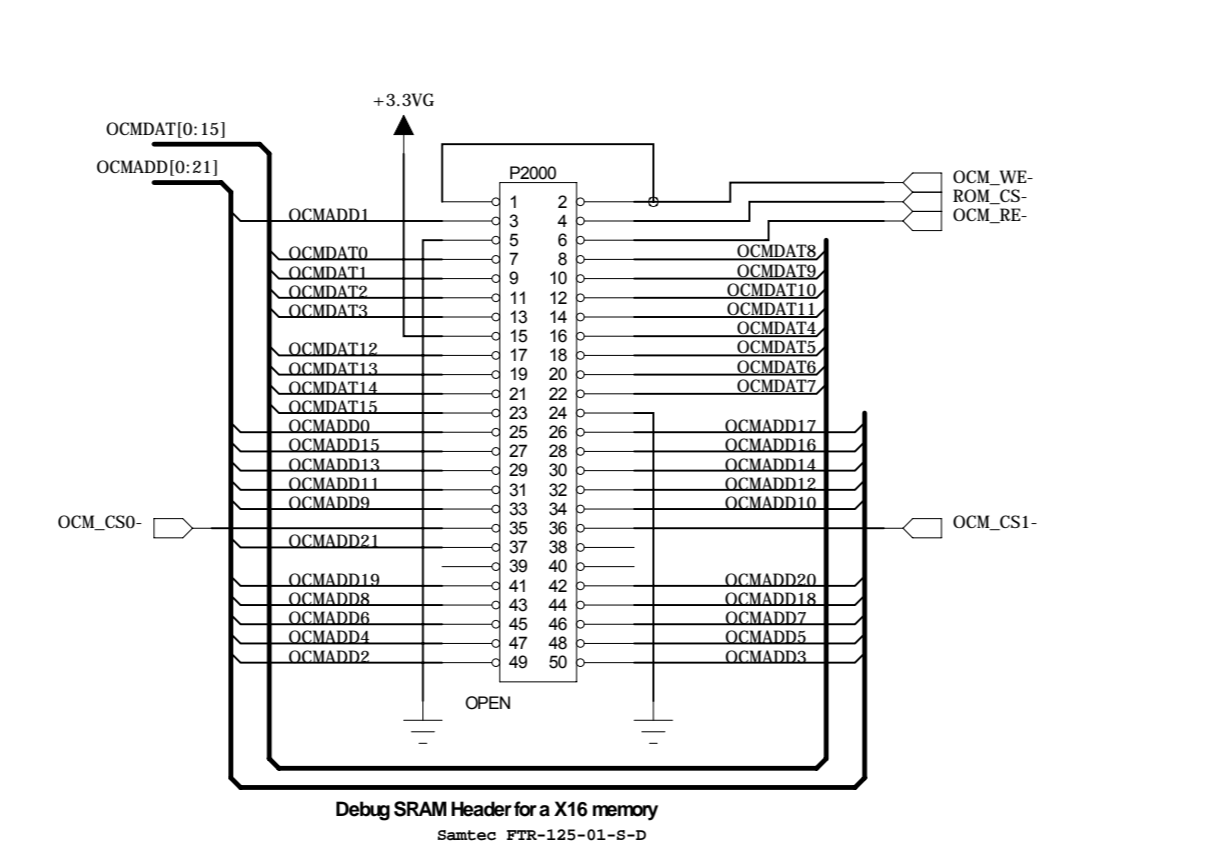
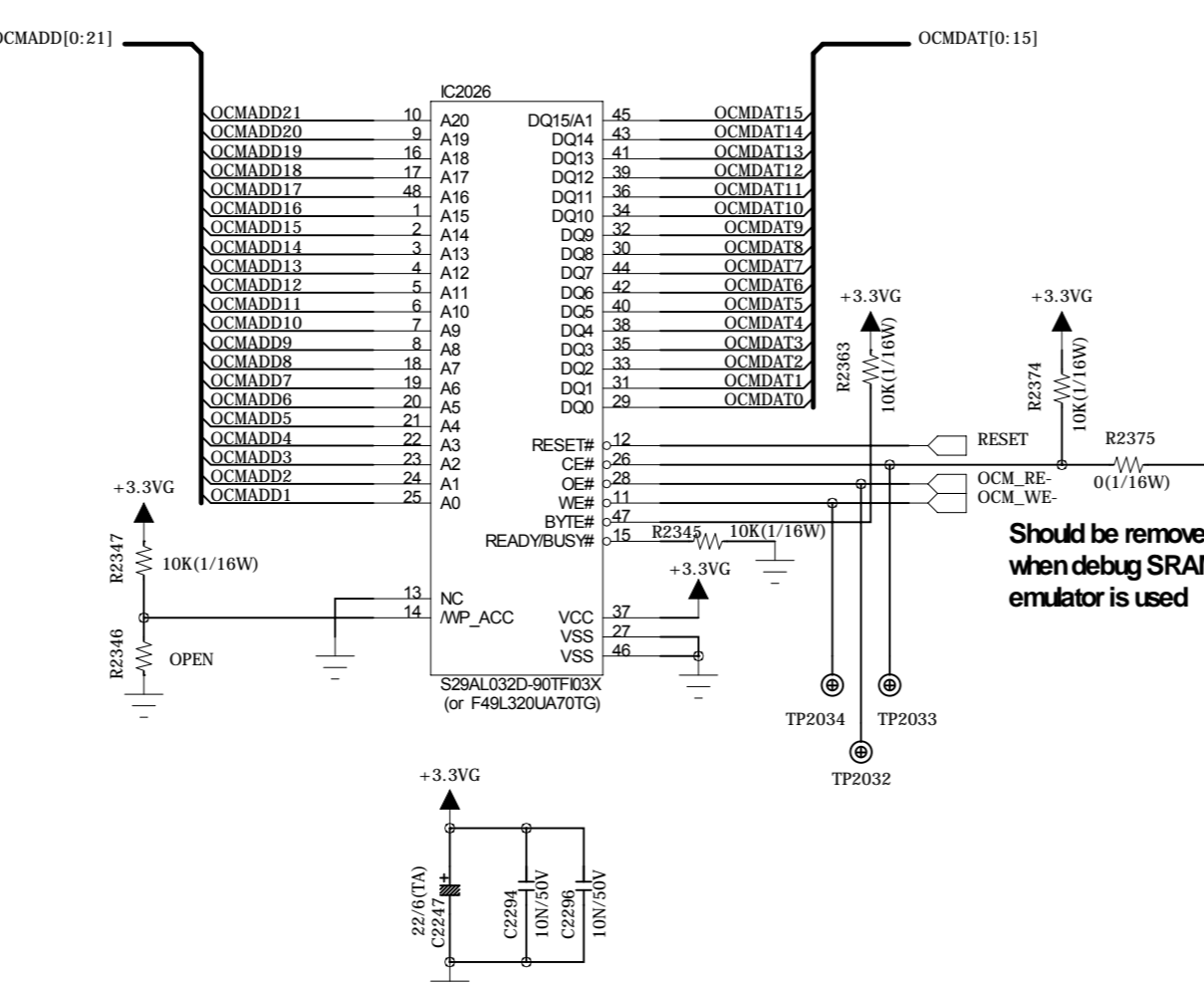
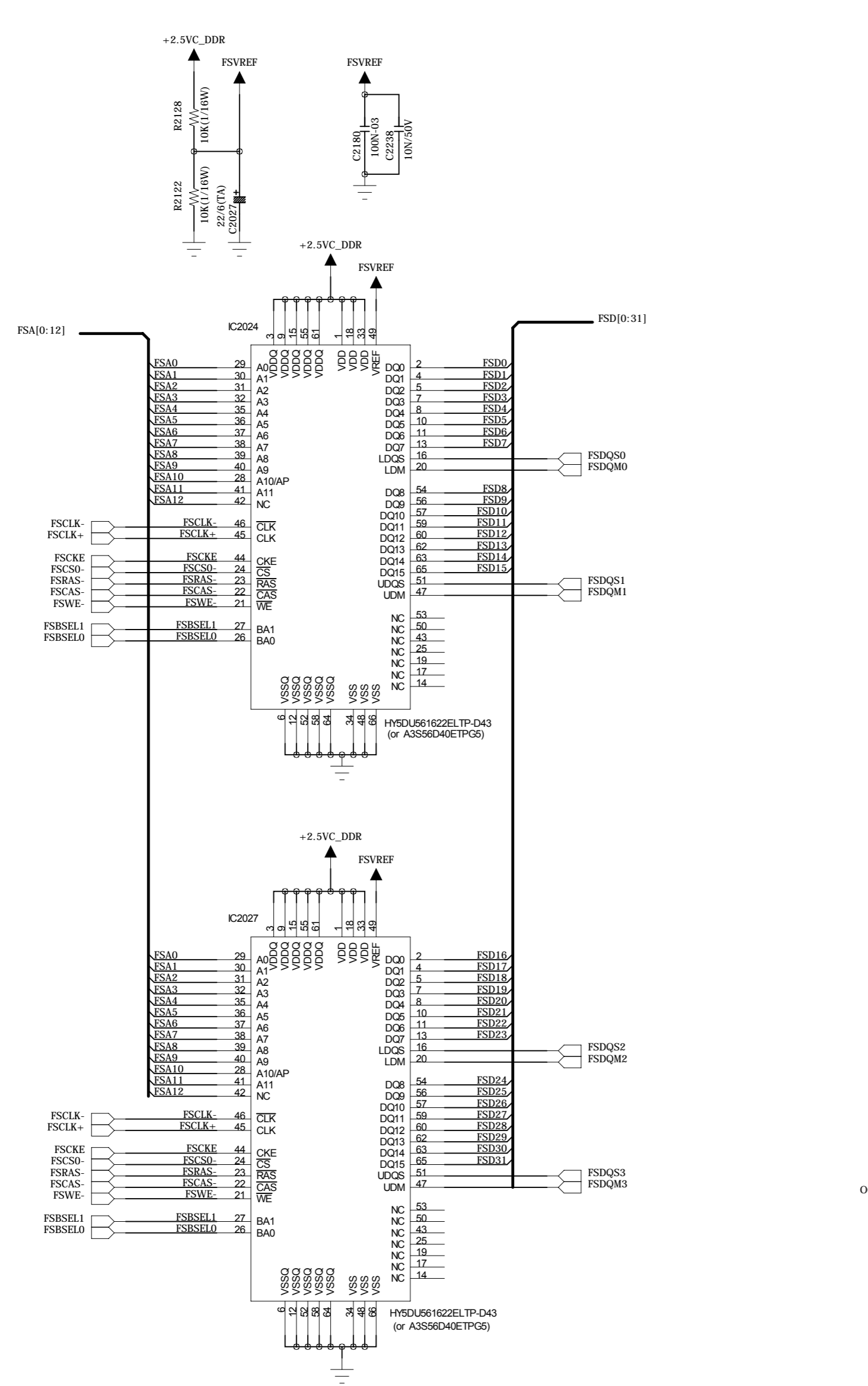

6:0:	IC2 to JTAG bridge address or General use
12:7:	For General Purpose use
15:	14: 000 = 20-bit address, 8-bit EXT IF 001 = 24-bit address, 8-bit EXT IF 010 = 20-bit address, 16-bit EXT IF 011 = 24-bit address, 16-bit EXT IF 1XX = OCM disabled, external parallel control bus (testbench)
16:	Open (Internal ROM on, and mapped to top 32K) Close (Internal ROM off-boot from ext ROM)
18:	17: 00 = IC2 to JTAG Bridge disabled 01 = IC2, SDA on VGA1, SDA, ICD, SCL on VGA1, SCL 10 = ICD, SDA on VGA0, SDA, ICD, SCL on VGA0-SCL 11 = IC2 to JTAG bridge disabled, 5 JTAG signals mapped to AVS Pins
19:	Open (External Oscillator on TCLK pin) Close (XTAL and Internal Oscillator)

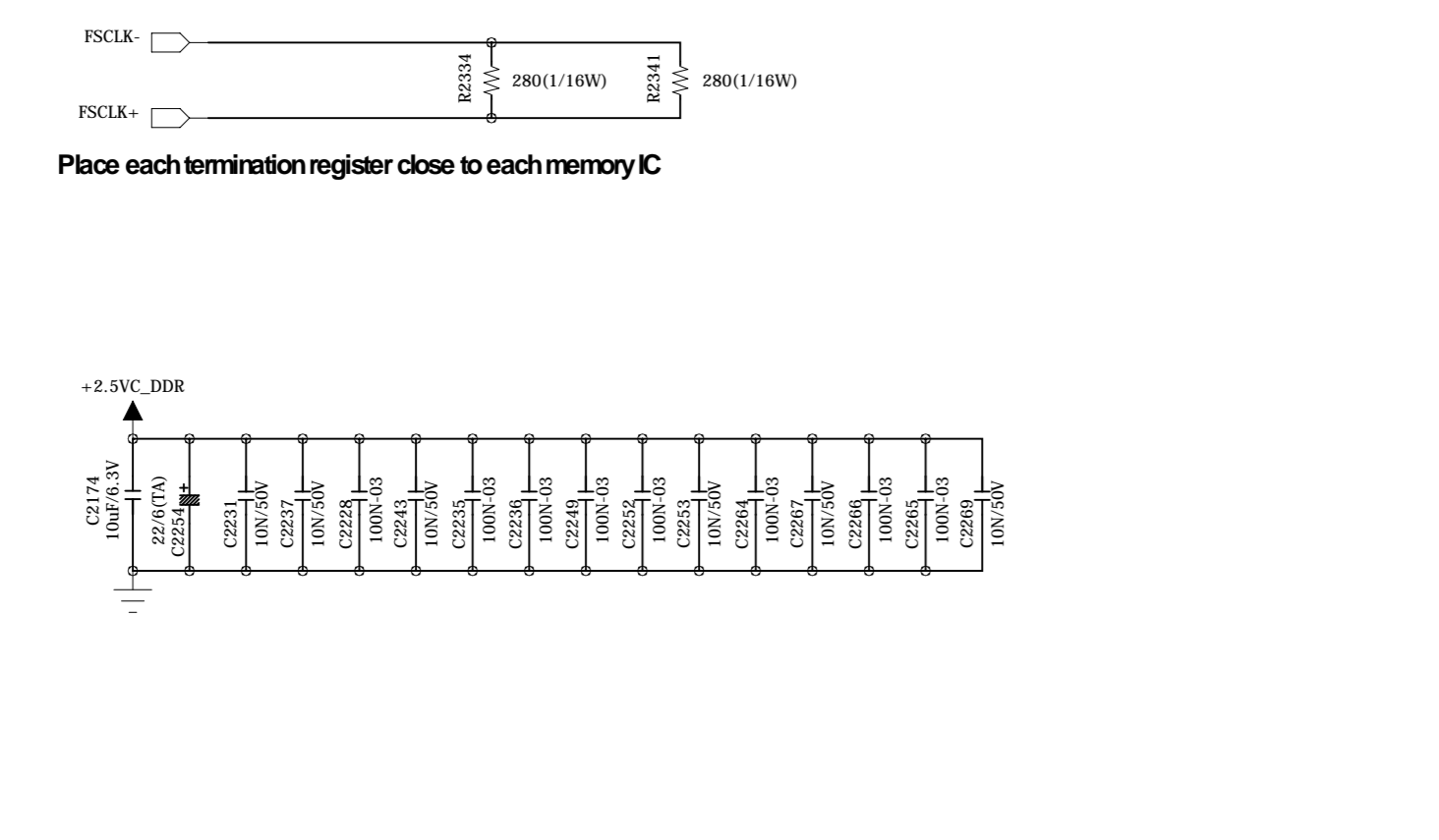
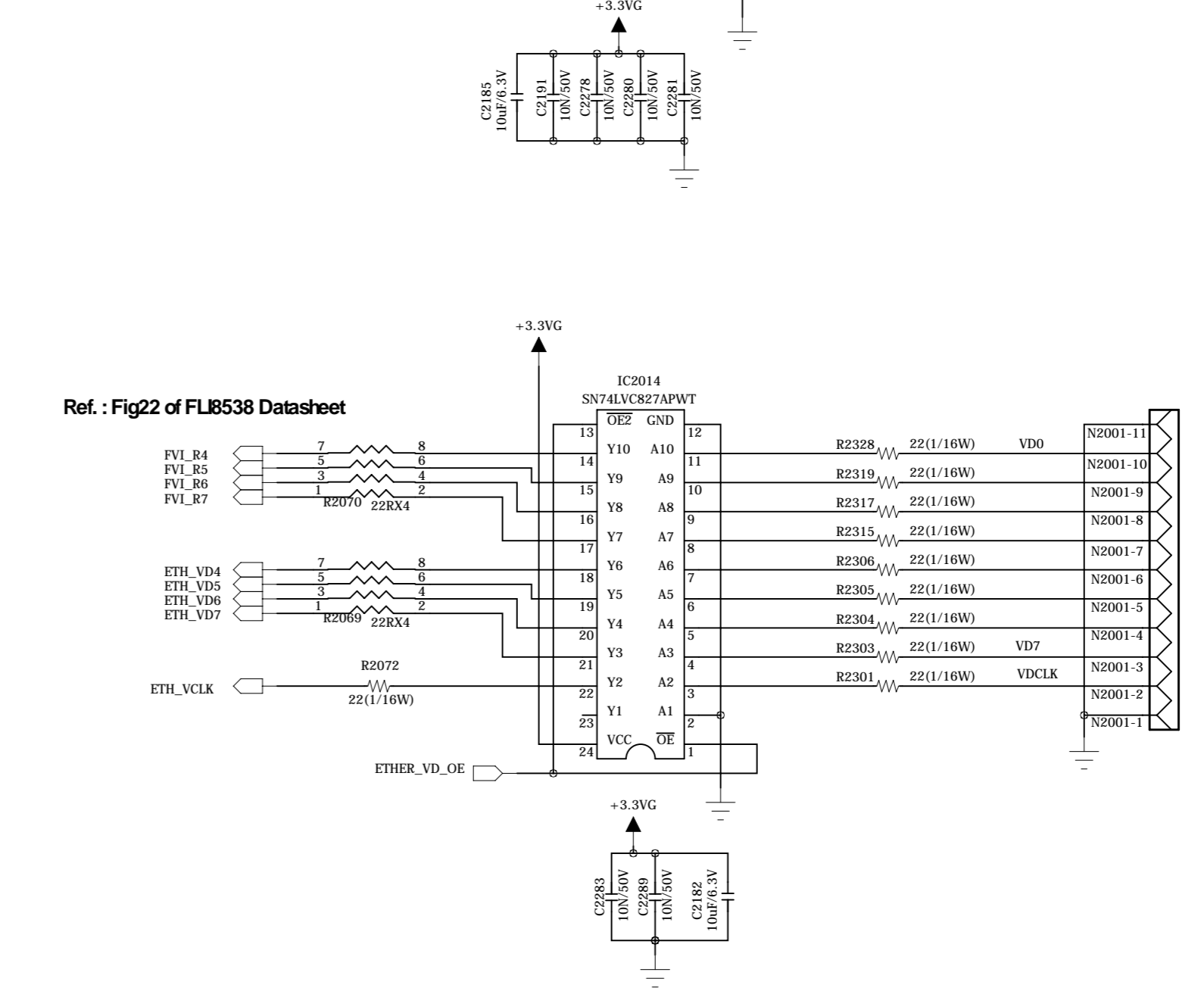
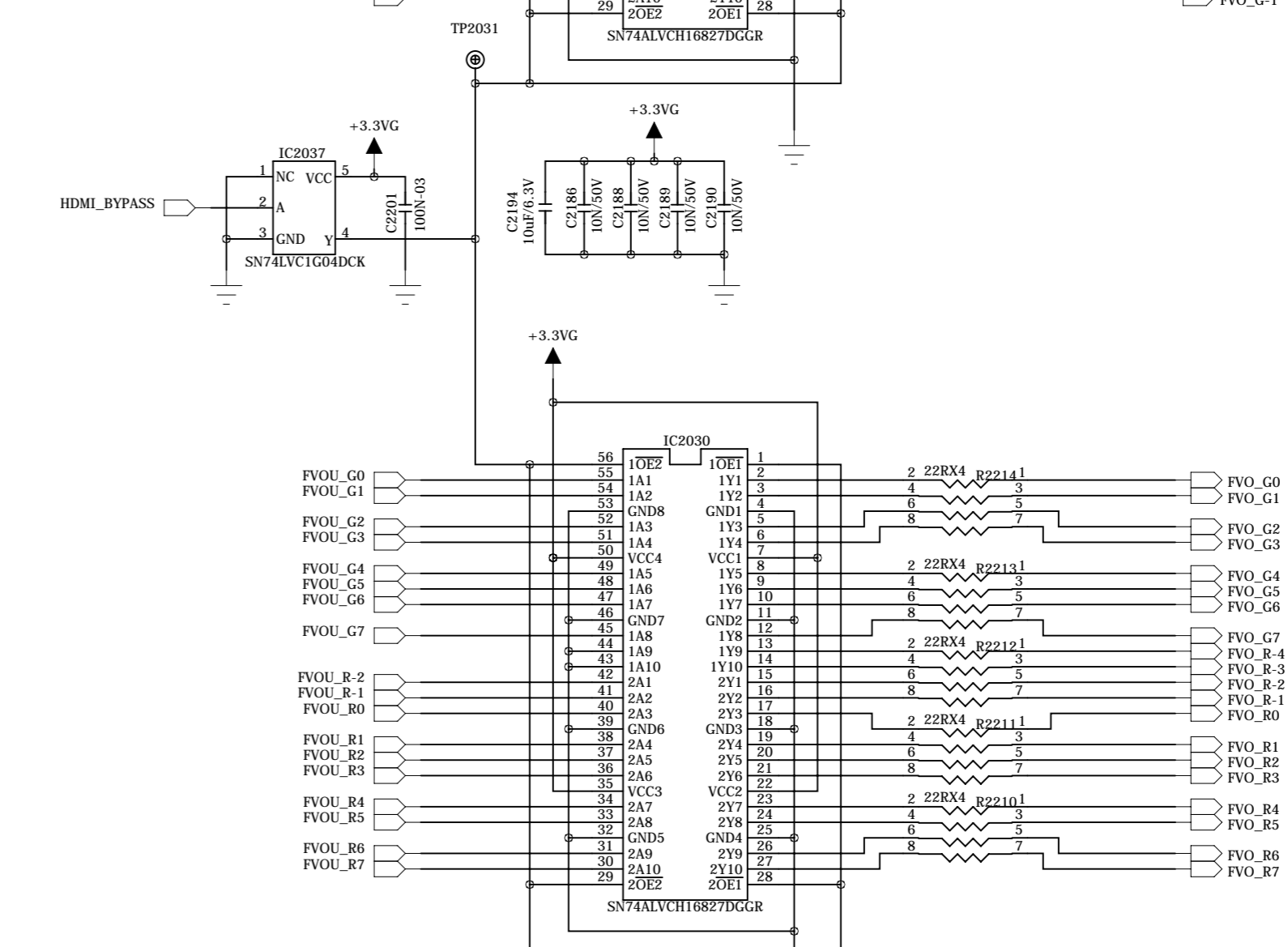
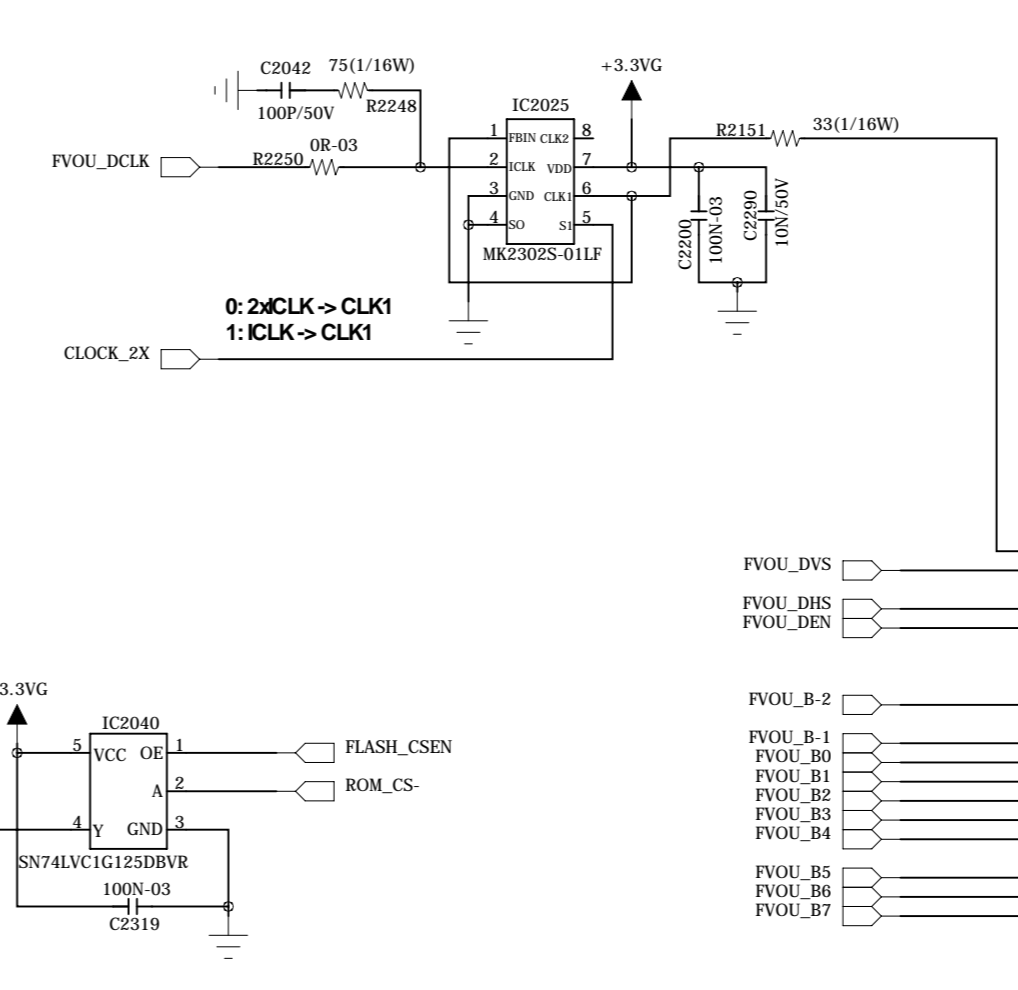

Category	A/V RECEIVER	Model	HK AVR7550HD
Stage	Ver.	Sheet	B'D name
MP	1.1	2 / 6	HDMI
Draw	Approved	Date	Drawing No
GS / SK		2009. 04. 13	

AVR 7550HD

harman/kardon

REVISION RECORD		
NO.	Date	Contents

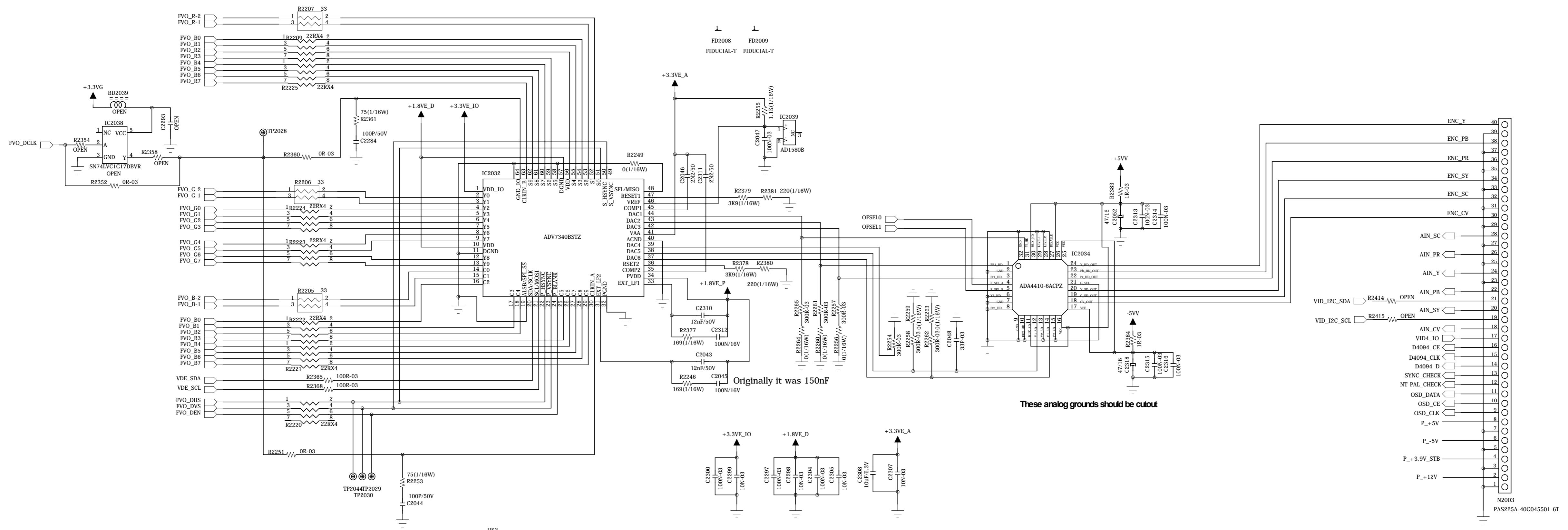

TO TORINO

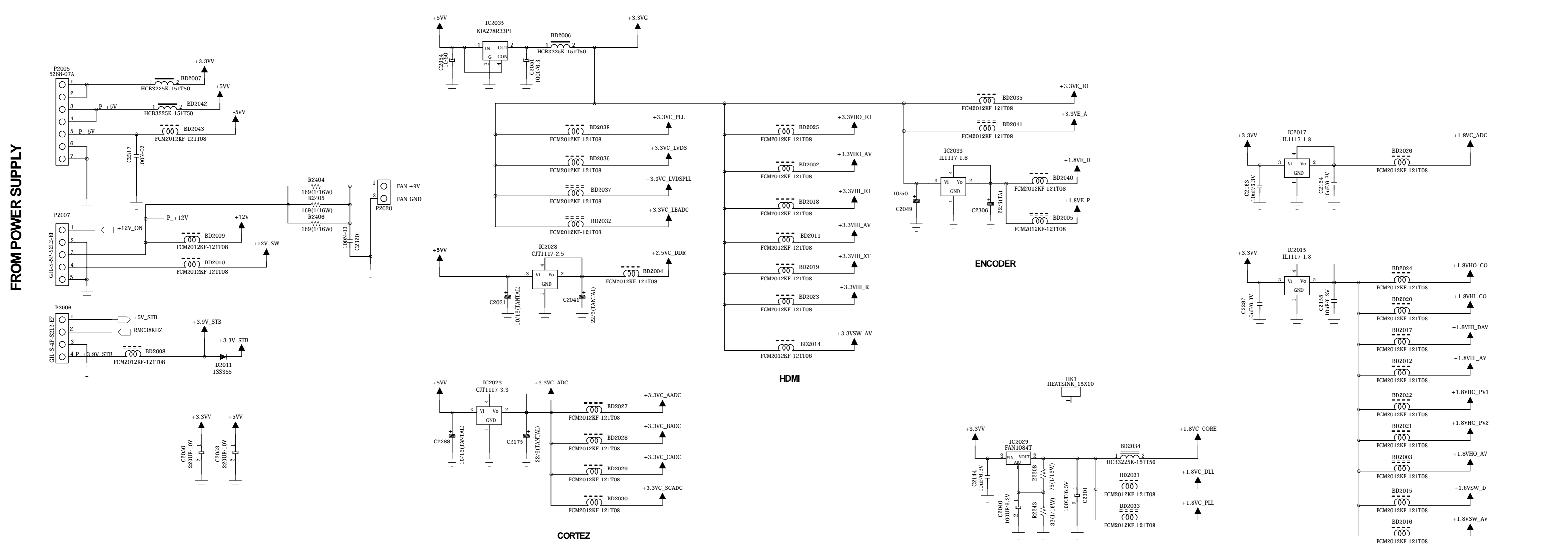

Category	A/V RECEIVER	Model	HK AVR7550HD
Stage	Ver.	Sheet	B'D name
MP	1.1	3 / 6	HDMI
Draw	Approved	Date	Drawing No
GS / SK		2009. 04. 18	

AVR 7550HD

harman/kardon

REVISION RECORD		
NO.	Date	Contents

(* C2001 was 1n2. It is changed to 2n2 due to ANAM request.

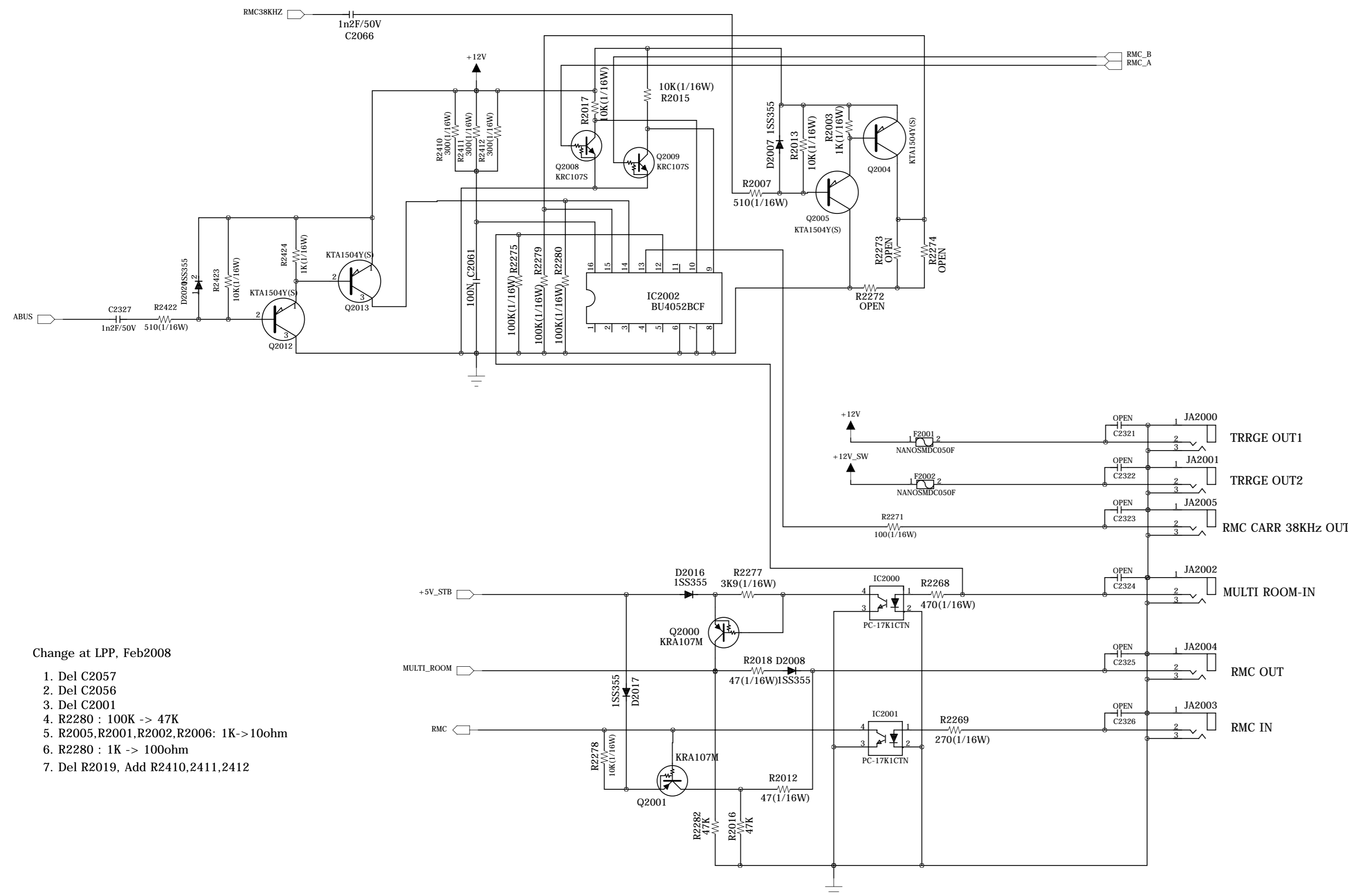

- Change at LPP, Feb2008
1. Del C2057
 2. Del C2056
 3. Del C2001
 4. R2280 : 100K -> 47K
 5. R2005, R2001, R2002, R2006: 1K -> 10ohm
 6. R2280 : 1K -> 100ohm
 7. Del R2019, Add R2410, 2411, 2412

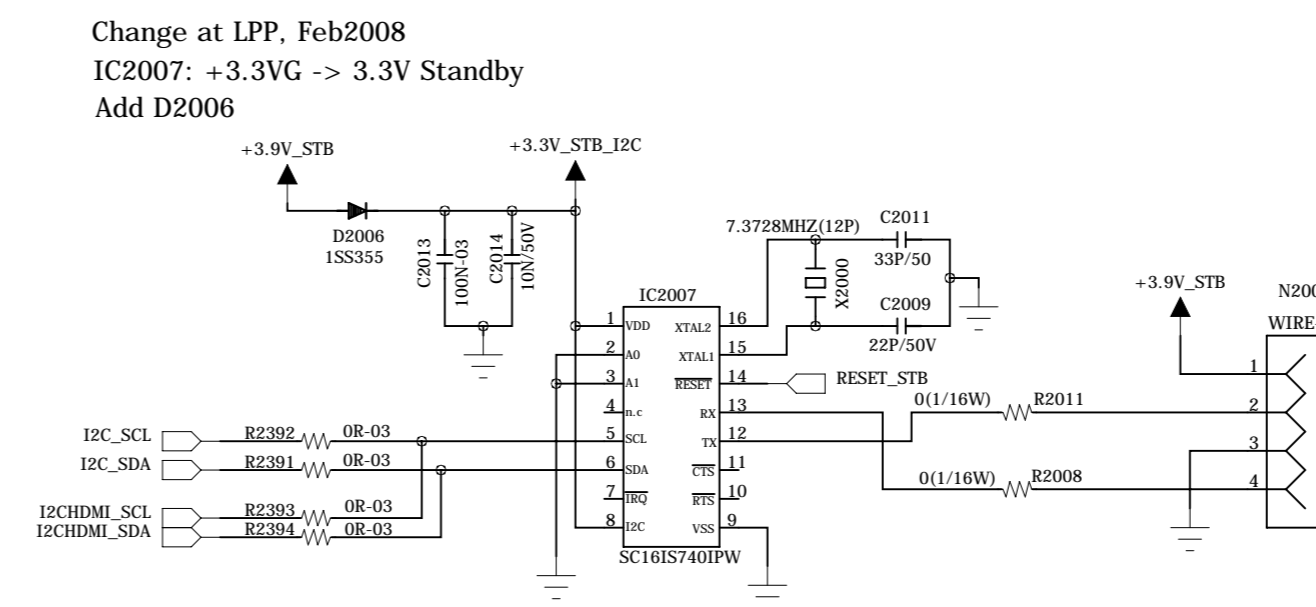

Change at LPP, Feb2008
IC2007: +3.3V -> 3.3V Standby
Add D2006

Category	A/V RECEIVER	Model	HK AVR7550HD
Stage	Ver.	Sheet	B'D name
MP	1.1	6 / 6	HDMI
Draw	Approved	Date	Drawing No
GS / SK		2009. 04. 13	

Schematic Diagram

REVISION RECORD		
NO.	Date	Contents

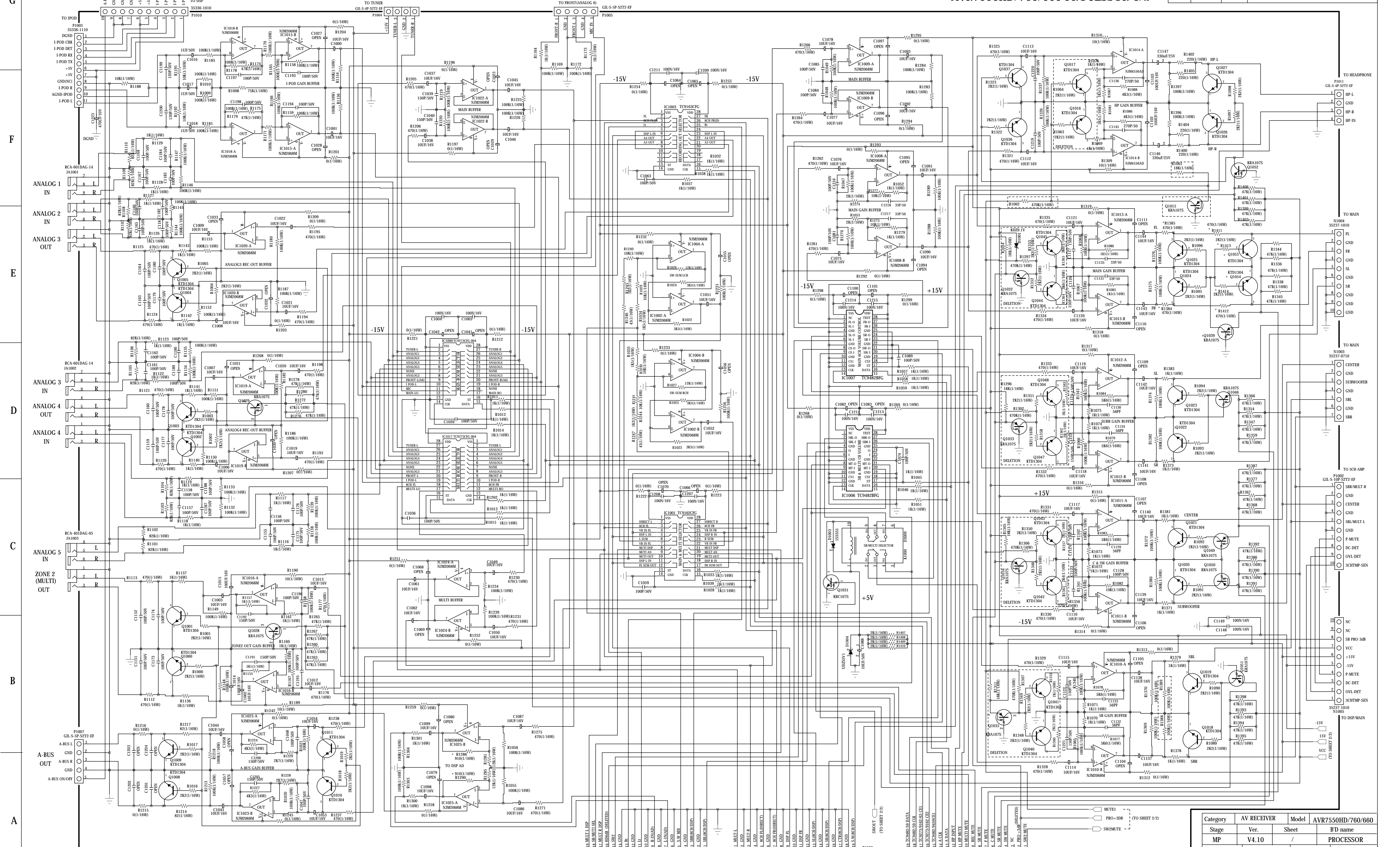

Category	AV RECEIVER	Model	AVR7550HD/760/660
Stage	Ver.	Sheet	B'D name
MP	V4.10		PROCESSOR
Draw	Approved	Date	Drawing No
J C EOM		APR. 13.2009	

Schematic Diagram

harman kardon
AVR7550HD/760/660PROCESSOR 2/2

REVISION RECORD

NO.	Date	Contents

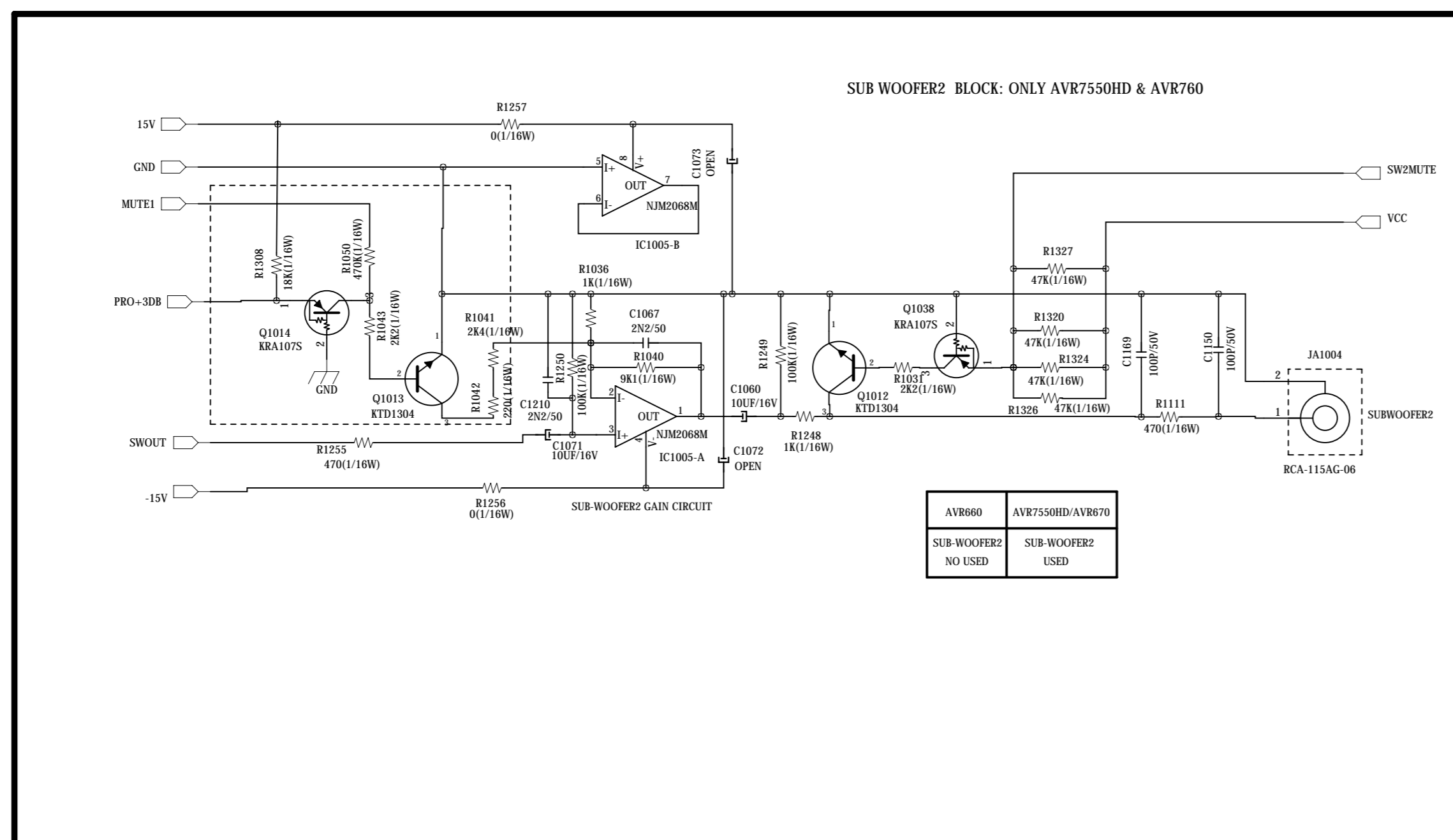

AVR660	AVR7550HD/AVR760
SUB-WOOFER2	SUB-WOOFER2
NO USED	USED

*** THE UNIT OF RESISTANCE IS OHM.
 K=1000 OHM M=1000 MICRO
 *** THE UNIT OF CAPACITANCE IS MICROFARAD (uF)
 P=10 PF
 *** THIS SCHEMATIC DIAGRAM MAY MODIFIED AT ANYTIME WITH THE
 IMPROVEMENT OF PERFORMANCE.

Category	AV RECEIVER	Model	AVR7550HD/760/660
Stage	Ver.	Sheet	B'D name
MP	V4.10	/	PROCESSOR
Draw	Approved	Date	Drawing No
		APR.13.2009	

Wiring Diagram

AVR 7550HD

harman/kardon

Harman/Kardon

AVR7550HD/760/660

REVISION RECORD		
NO.	Date	Contents

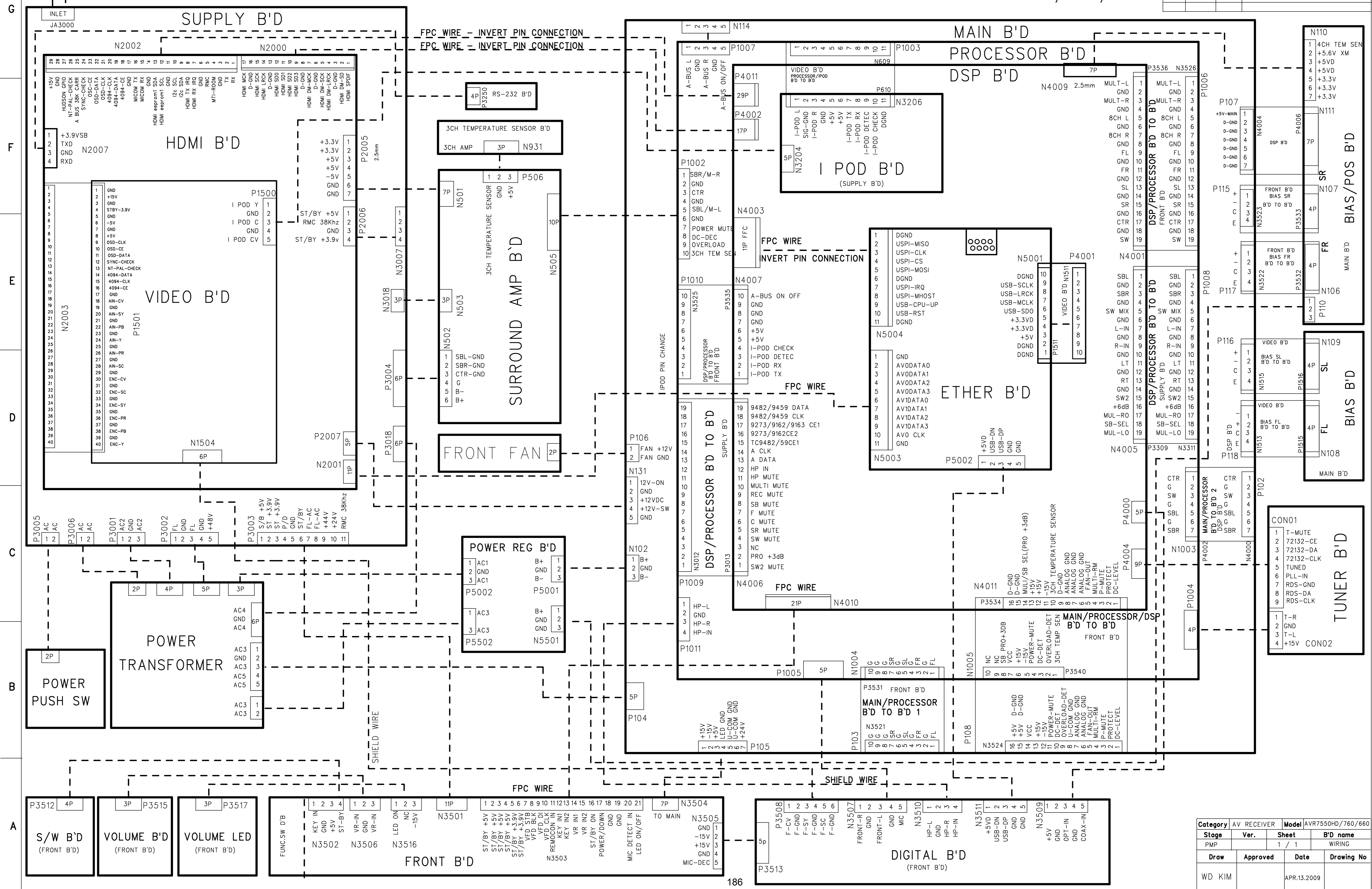

Category	AV RECEIVER	Model	AVR7550HD/760/660
Stage	Ver.	Sheet	B'D name
PMP		1 / 1	WIRING
Draw	Approved	Date	Drawing No
WD KIM		APR.13.2009	