

SERVICE MANUAL

SOLID-STATE AM/FM STEREO TUNER AMPLIFIER

SANSUI 800



Sansui[®]

SANSUI ELECTRIC COMPANY LIMITED

CONTENTS

Troubleshooting Chart	3, 4
Disassembly Procedure.....	5
Block Diagram	6
Custom Mounting.....	7, 8
Parts Layout.....	9, 10
Alignment—Test Points	11
—FM Alignment Procedure	12
—FM M.P.X. Alignment Procedure	13
—AM Alignment Procedure.....	14
Printed Circuit Sheets	
and Parts List	15, 16, 17, 18, 19, 20, 21, 22, 23
Other Parts and Their Position on Chassis.....	24, 25, 26



TROUBLESHOOTING CHART

If the amplifier is otherwise operating satisfactorily, the more common causes of trouble may generally be attributed to the following:

1. Incorrect connections or loose terminal contacts. Check the speakers, record player, tape recorder, antenna and line cord.
2. Improper operation. Before operating any audio component, be sure to read the manufacturer's in-

structions.

3. Improper location of audio components. The proper positioning of components, such as speakers and turntable, is vital to stereo.

4. Defective audio components.

Following are some other common causes of malfunction and what to do about them:

PROGRAM	SYMPTOM	PROBABLE CAUSE	WHAT TO DO
AM, FM or MPX reception	A. Constant or intermittent noise heard at certain times or in a certain area.	<ul style="list-style-type: none"> * Discharge or oscillation caused by electrical appliances, such as fluorescent lamps, TV sets, D.C. motors, rectifier and oscillator * Natural phenomena, such as atmospheric, static, and thunderstorms. * Insufficient antenna input due to reinforced concrete walls or long distance from the station * Wave interference from other electrical appliances 	<ul style="list-style-type: none"> * Attach a noise limiter to the electrical appliance that causes the noise, or attach it to the power source of the amplifier. * Install an outdoor antenna and ground the amplifier to raise the signal-to-noise ratio. * Reverse the power cord plug-receptacle connections. * If the noise occurs at a certain frequency, attach a wave trap to the ANT. input. * Place the set away from other electrical appliances.
	B. Needle of the tuning meter does not move sharply.	<ul style="list-style-type: none"> * Needle movement is not necessarily related to the sensitivity of the amplifier. 	<ul style="list-style-type: none"> * Tune the set for maximum signal strength.
	C. Zero point of the meter moves greatly.	<ul style="list-style-type: none"> * Regional difference in field intensity. 	<ul style="list-style-type: none"> * The unit is not at fault.
AM reception	A. Noise heard at a particular time of day, in a certain area or over part of the dial.	<ul style="list-style-type: none"> * Natural AM reception phenomenon. 	<ul style="list-style-type: none"> * Install an antenna for maximum antenna efficiency. See "ANTENNA" in the Operating Instructions. * In some causes, the noise can be eliminated by grounding the amplifier or reversing the power cord plug-receptacle connections.
	B. High-frequency noise	<ul style="list-style-type: none"> * Adjacent-channel interference or beat interference * TV set is too close to the audio system 	<ul style="list-style-type: none"> * Although such noise cannot be eliminated by the amplifier, it is advisable to turn the TREBLE control from midpoint to left and switch on the HIGH FILTER. * Place the TV set away from the audio system.
FM reception	A. Noisy	<ul style="list-style-type: none"> * Poor noise limiter effect or too low S/N ratio due to insufficient antenna input. 	<ul style="list-style-type: none"> * Adjust the antenna provided for maximum signal strength. * If this is not effective, use an outdoor antenna designed exclusively for FM. When you use a TV antenna for both TV and FM with a divider, make sure TV reception is not affected. * An excessively long antenna may cause noise.
		<p>NOTE: FM reception is affected considerably by the conditions of the transmitting stations power and antenna efficiency. As a result, you may receive one station quite well while having difficulty receiving another station.</p>	

PROGRAM	SYMPTOM	PROBABLE CAUSE	WHAT TO DO
FM reception (Cont'd)	B. "Scratch-like" noise is heard	* Ignition noise caused by the starting of an automobile.	* Install the antenna and its lead-in wire away from the road or raise the antenna input as previously described.
	C. Tuning noise between stations	* This noise results from the nature of FM reception. As the station signal becomes weak, the noise limiter effect is decreased. The amplification of the limiter, in turn, is enlarged and a noise is generated.	* Turn on the MUTING switch. Since it also reduces the sensitivity, it should be used sparingly.
FM-MPX reception	A. Noise heard during FM-MPX reception while not heard during FM mono reception	* The service area of the FM-MPX broadcast is only half that of the FM mono broadcast.	* Install the antenna for maximum antenna input. * Switch on the HIGHFILTER and/or turn the TREBLE control from midpoint to left.
	B. Clearness of channel separation is decreased during reception.	* Excess heat	* Make sure that air can flow underneath the amplifier.
	C. The stereo indicator goes on and off.	* Interference * Station signal is weak	* The indicator is not at fault.
	D. The stereo indicator goes on and off even though a stereo station is not received.	* Interference	* The indicator is not at fault.
Record playing or tape playback	A. Hum or howling	* Record player placed directly on the speaker box. * Use of unshielded wire. * Loose terminal contact. * Shielded wire too close to line cord fluorescent lamp or other electrical appliances. * Nearby amateur radio station or TV transmission antenna.	* Put a cushion between the player and the speaker box or separate them. * The connecting shield wire should be as short as possible. * Turn the BASS control from midpoint to left. * Consult the nearest Radio Regulatory Bureau.
	B. Surface noise	* Worn or old record * Worn pick-up needle * Dusty needle * Improper needle pressure	* Recondition the playback head of the tape recorder or the pick-up of the record player * Turn the TREBLE control properly from midpoint to left. * Switch on the HIGH FILTER.
Overall stereo program	The BALANCE control is not at midpoint when equal sound comes from left and right channels.	* It is important to adjust the control for equal sound from both channels. It should not always be set to midpoint.	* Set the MODE switch to the MONO position and then set the BALANCE control to the position where equal sound comes from both channels.

DISASSEMBLY PROCEDURE

REMOVING THE FRONT PANEL, BONNET AND BOTTOM PLATE

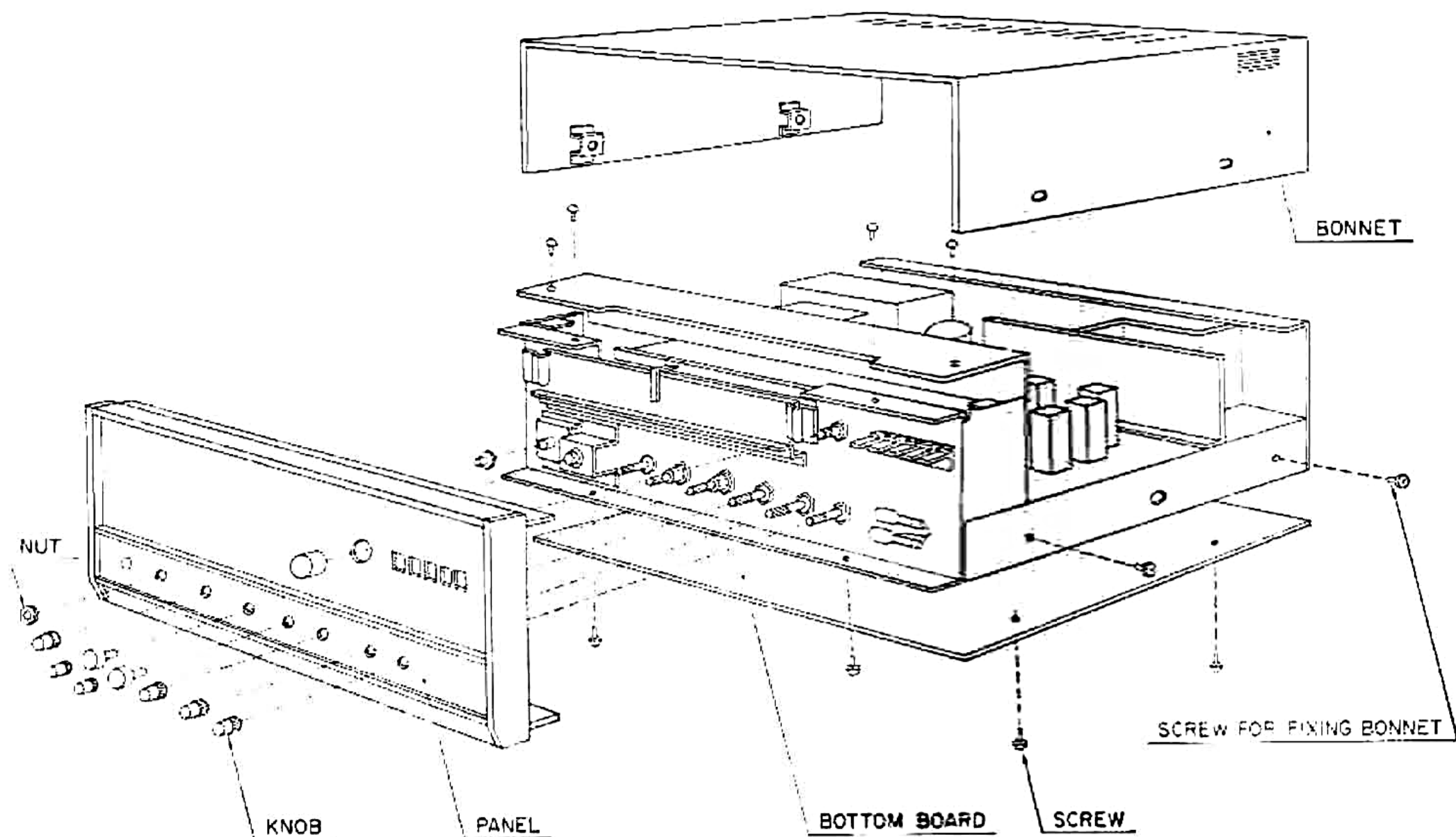

DIAL MECHANISM

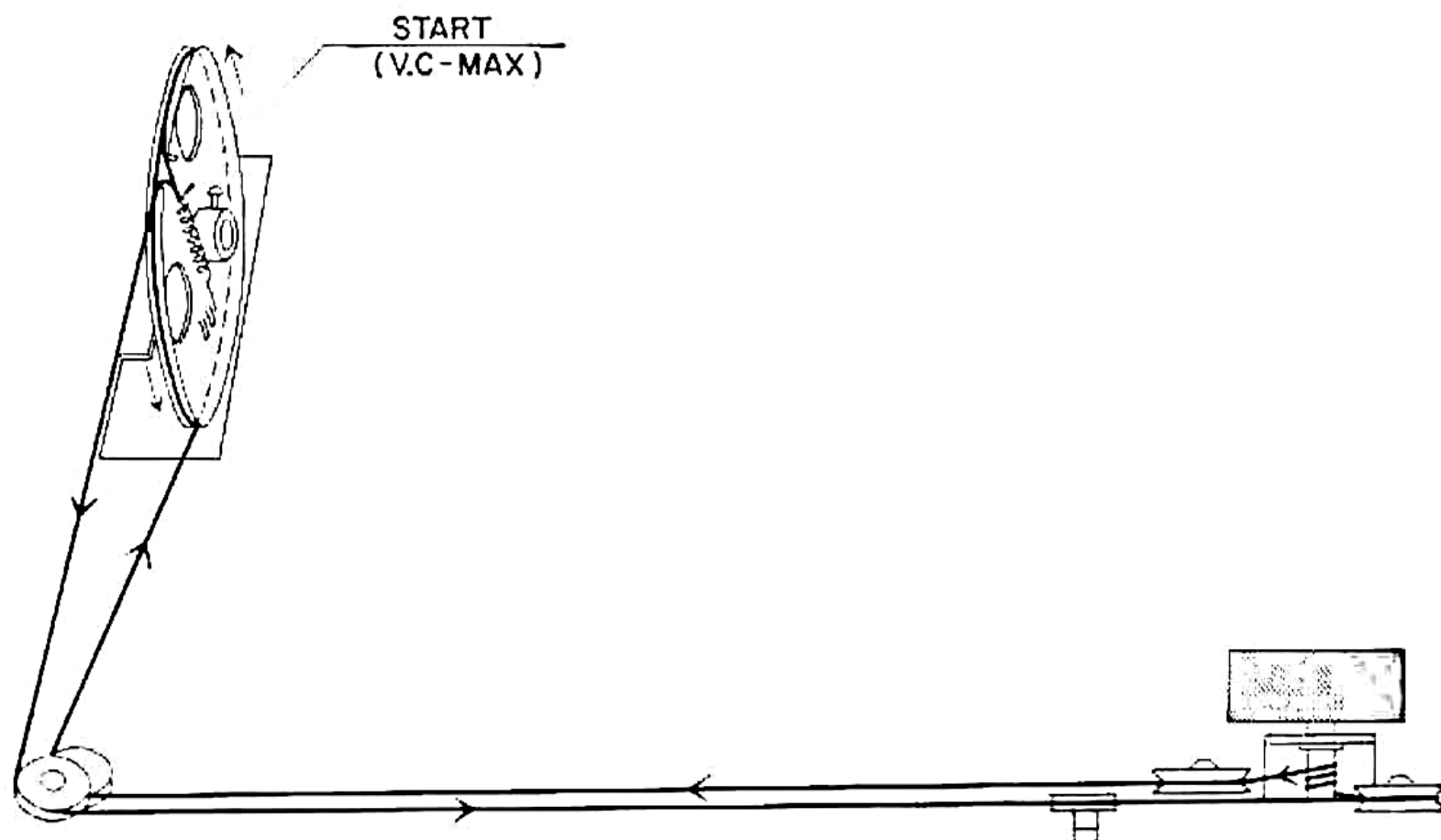

BLOCK DIAGRAM

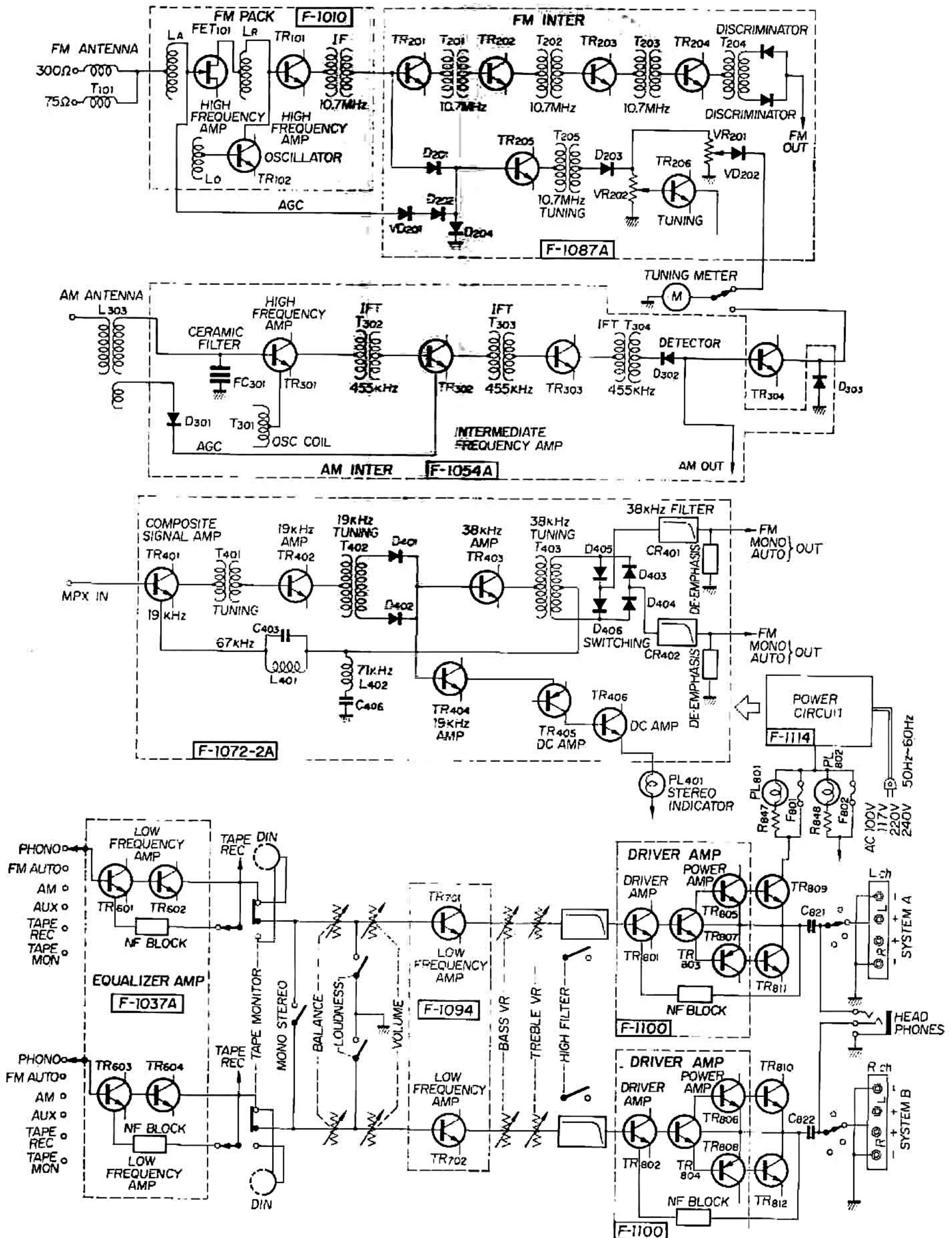

CUSTOM MOUNTING

1. Make a cabinet window of 392 mm or $15\frac{7}{16}$ " in width and 107 mm or $4\frac{1}{2}$ " in height.
2. Place two square pieces of wood ($20 \times 20 \times 280$ mm or $\frac{3}{8}$ " \times $\frac{3}{8}$ " \times $11\frac{1}{2}$ ") for supporting the amplifier in bottom board of the cabinet.
3. Cut two holes for attachment bolts in the bottom board of the cabinet.
4. Remove the four rubber pads from the amplifier

5. Place the amplifier in position through the cabinet window.
 6. Make sure the amplifier is in position, then put the washers in butterfly bolts (supplied) and fix the amplifier to the cabinet with butterfly bolts.
- NOTE: When the amplifier is built into the cabinet the four rubber pads are not used. Retain them for future use.

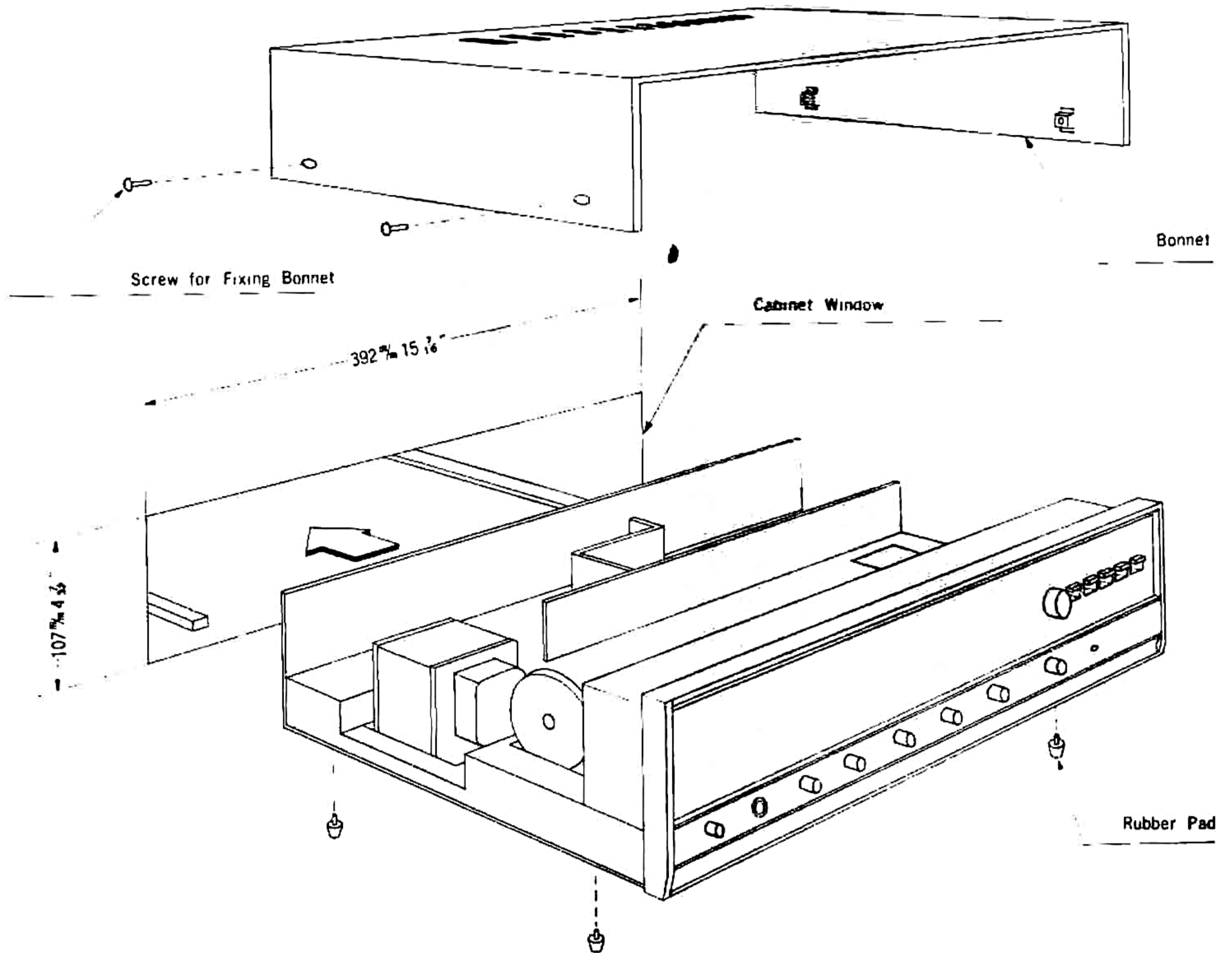

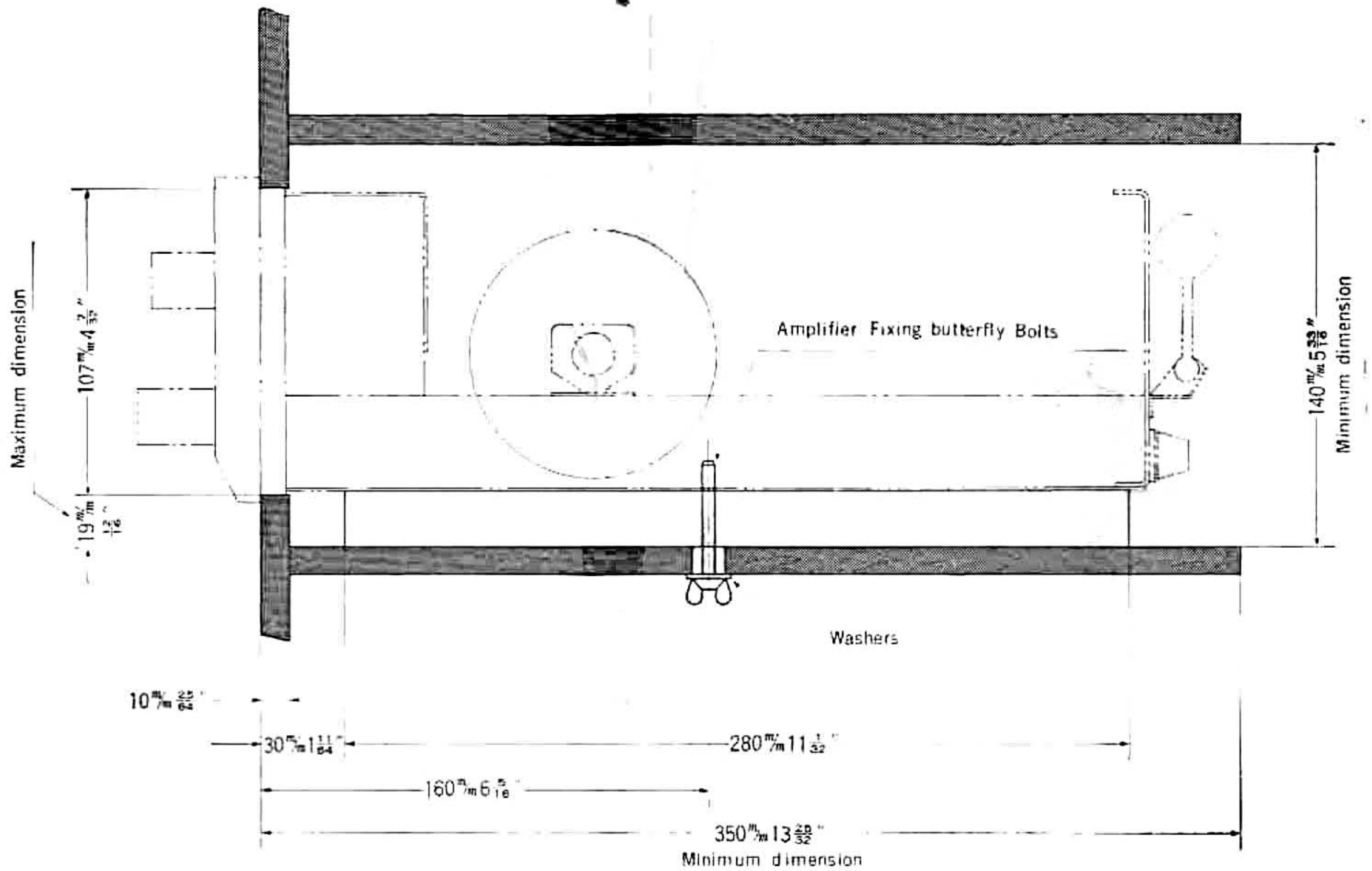
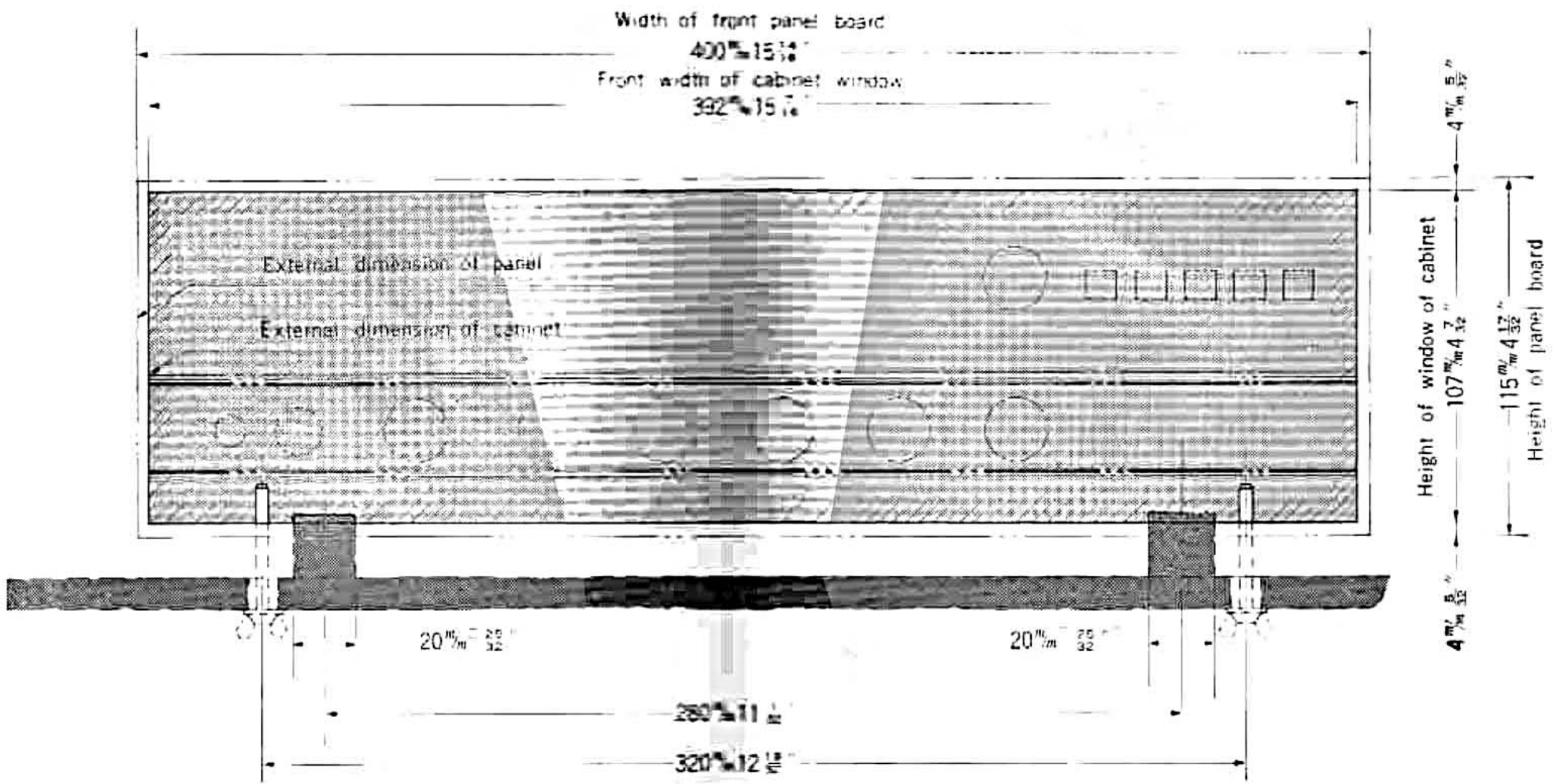

PARTS LAYOUT

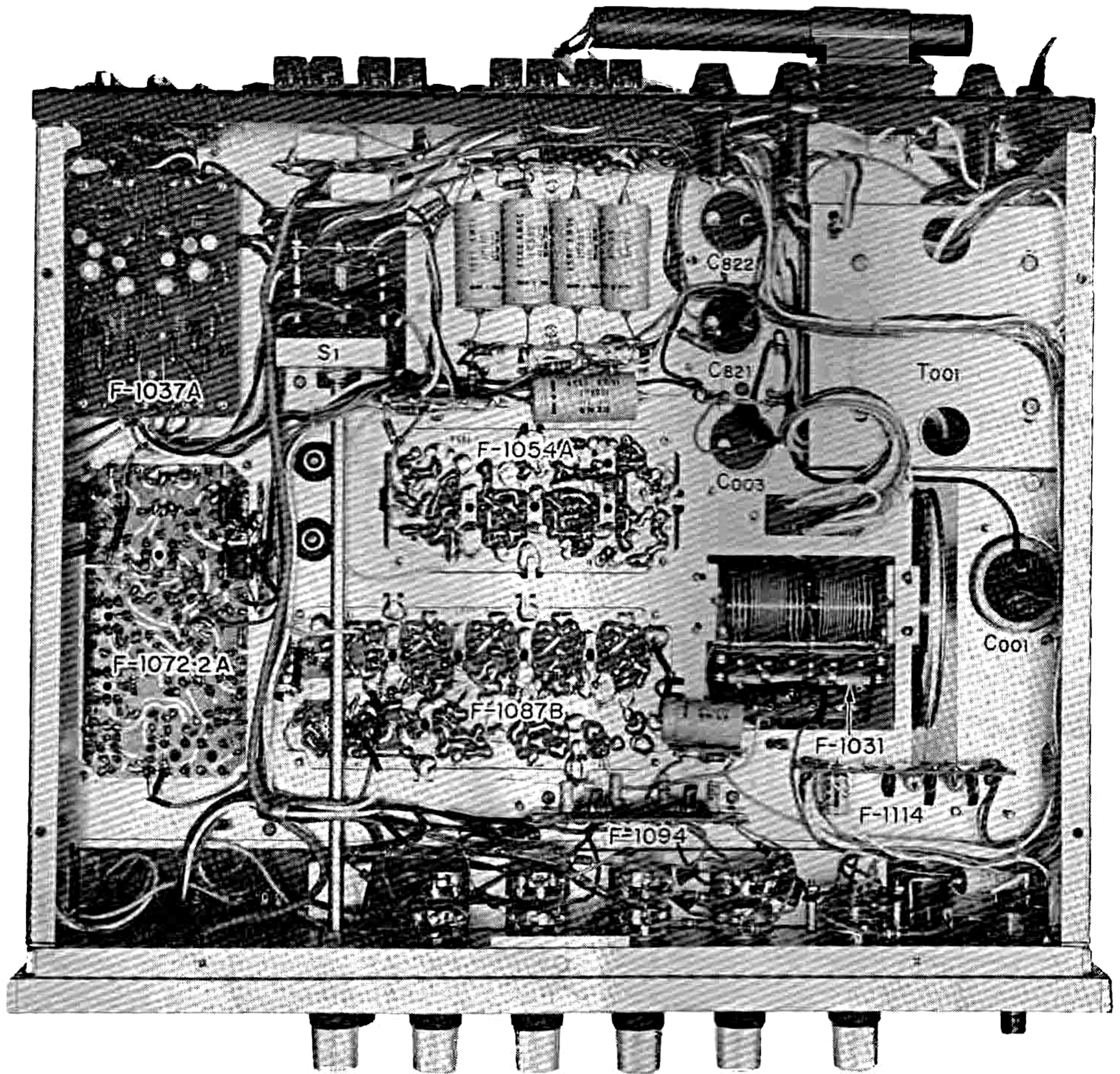

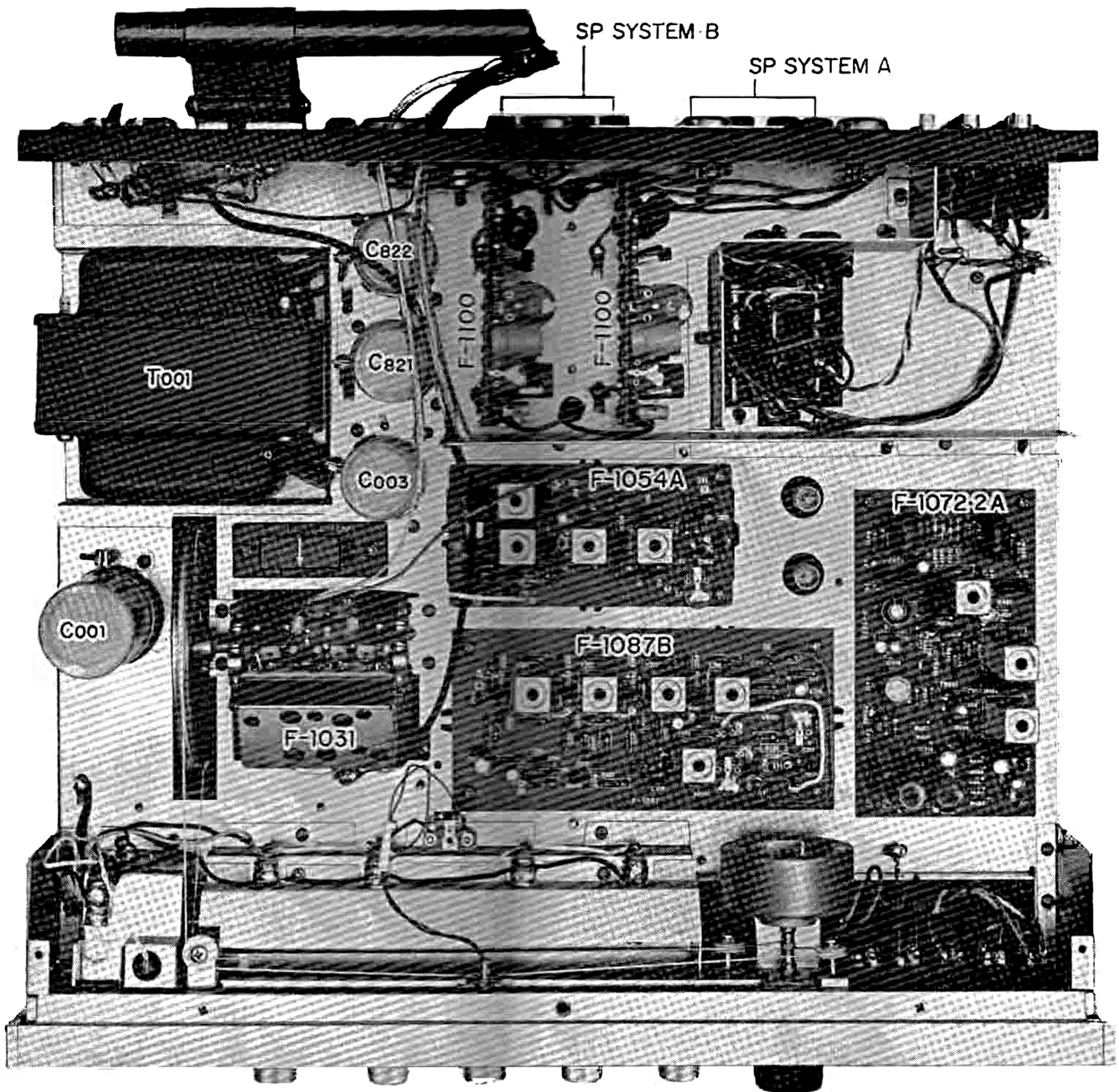

ALIGNMENT

TEST POINTS

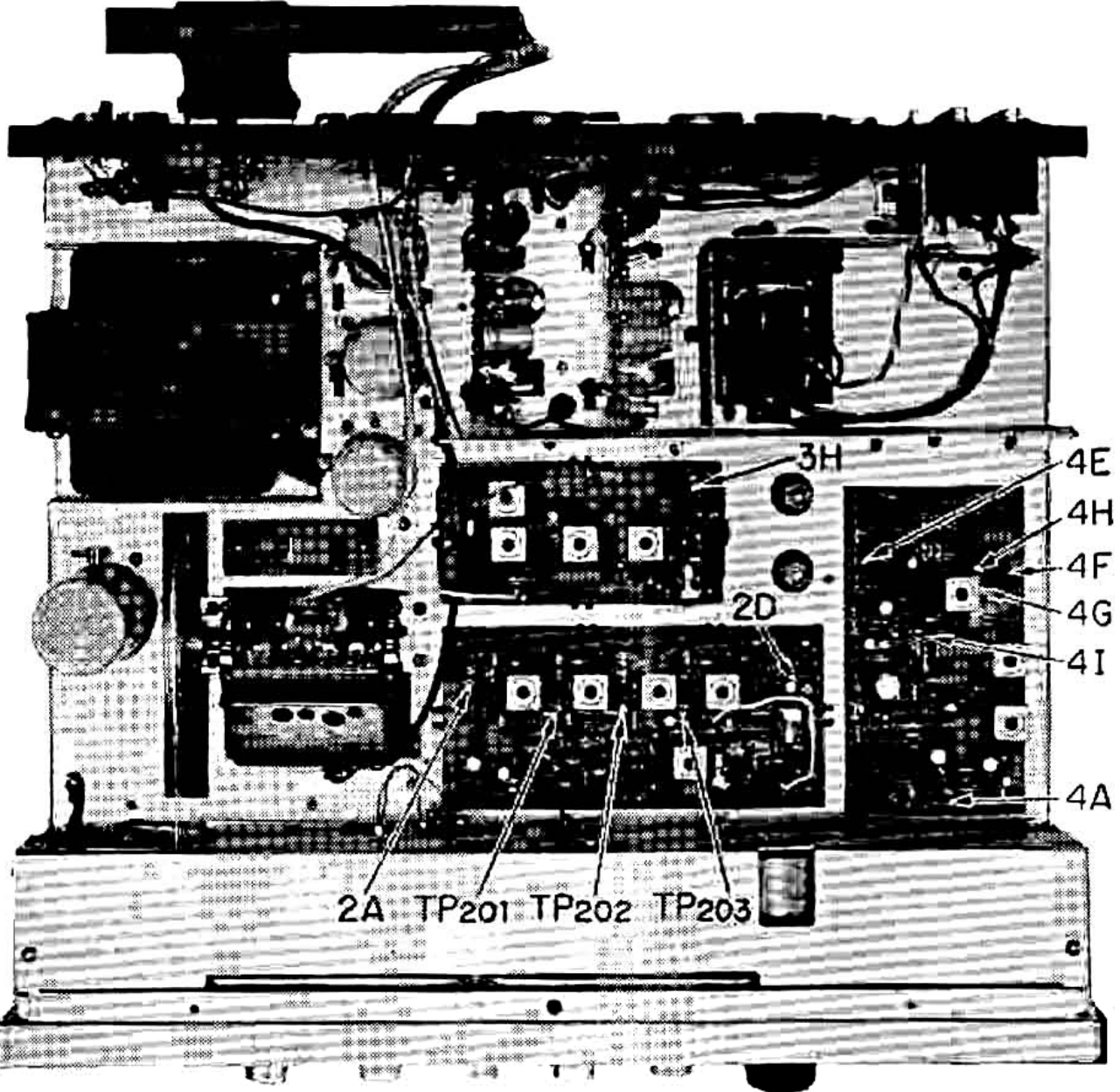
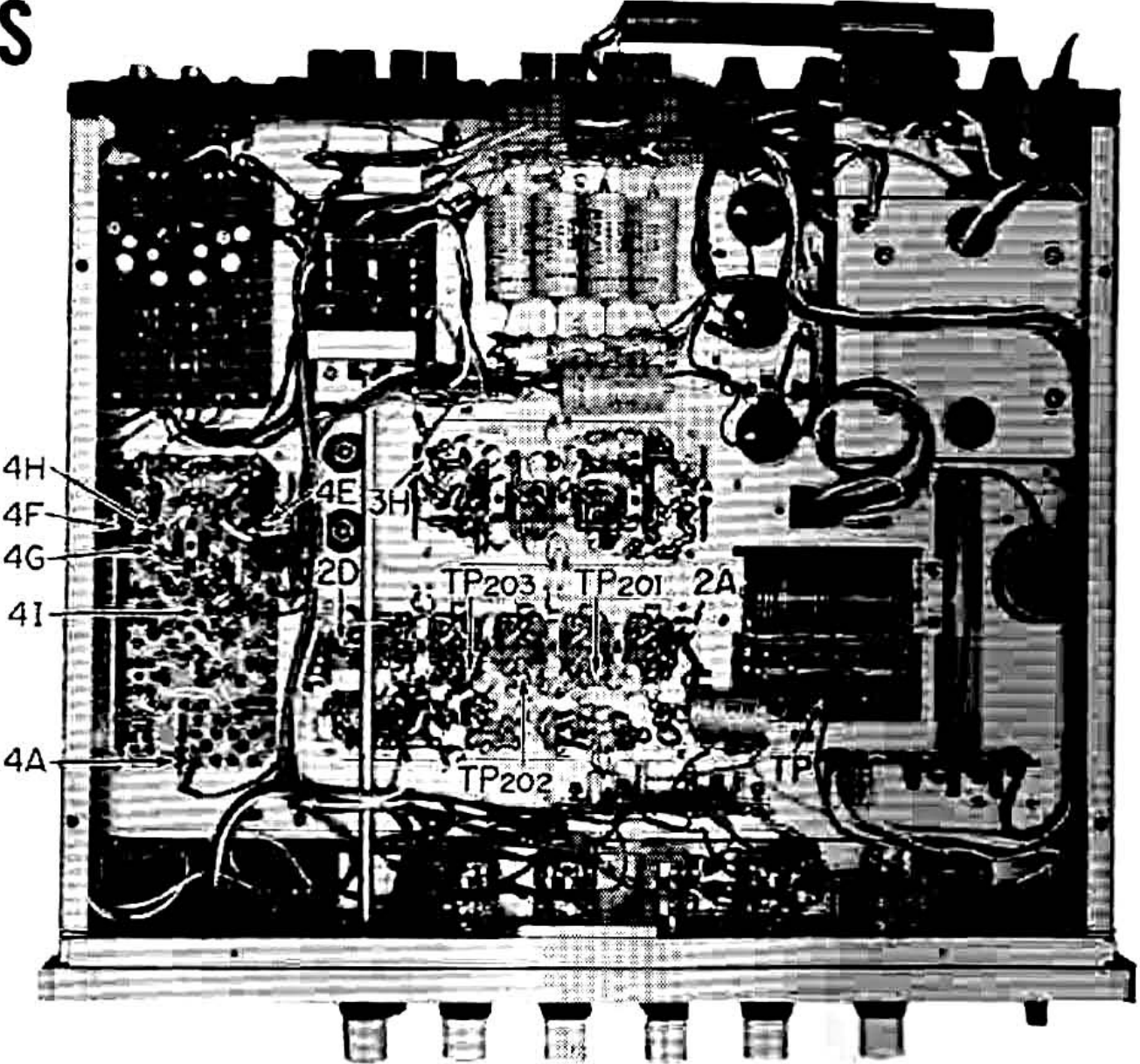

FM ALIGNMENT PROCEDURE

NOTE: To align, set the FM signal generator level to minimum turn tuning gang fully, center carrier wave, and set pointer to reference mark.

STEP	ALIGN	GENERATOR	FEED SIGNAL	OUTPUT INDICATOR	DIAL SETTING	ADJUST	ADJUST FOR
1.	IF Trans- former	10.7MHz ±200 kHz	Sweep signal is sent to TP _{1st} via the 0.02μF ceramic capacitor	Oscilloscope is connected to TR ₂₀₂ emitter, and then TR ₂₀₃ collector to ground via the 0.02μF ceramic capacitor		Primary and secondary sides of T ₂₀₁ , T ₂₀₂ , and T ₂₀₃	Best I.F.T. wave form
2.	Discrimin- ator	10.7 MHz ±200 kHz	Sweep signal is sent to 2A via the 0.02μF ceramic capacitor	Oscilloscope is connected to 2K via the 0.05μF capacitor		FM Discriminator transformer T ₂₀₄ primary and secondary	S curve
3.	O.S.C	88 MHz 400 Hz 100% Modulation	To antenna terminals	Oscilloscope and V.T.V.M. at output load	88 MHz	O.S.C. coil L ₀	Maximum
4.	O.S.C.	108 MHz 400 Hz 100% Modulation	To antenna terminals	Oscilloscope and V.T.V.M. at output load	108 MHz	O.S.C. trimmer TC ₁₀₄	Maximum
5.	Repeat 3&4						
6.	RF Amp. Circuit	90 MHz 400 Hz 100% Modulation	To antenna terminals	Oscilloscope and V.T.V.M. at output load	90 MHz	Antenna coil L _R , L _A and IF ₁	Maximum
7.	RF Amp. Circuit	106 MHz 400 Hz 100% Modulation	To antenna terminals	Oscilloscope and V.T.V.M. at output load	106 MHz	Trimmer TC _A and TC _R	Maximum
8.	Repeat 6&7						

FM IF CHARACTERISTIC

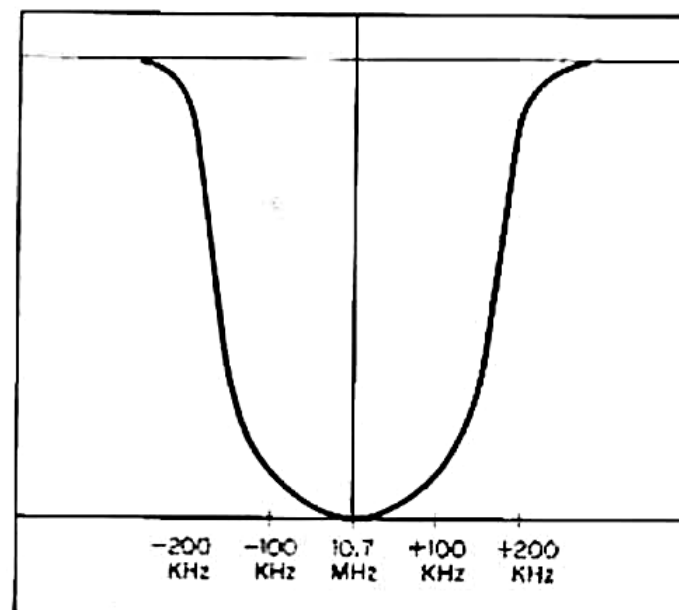

FM DISCRIMINATOR CHARACTERISTIC

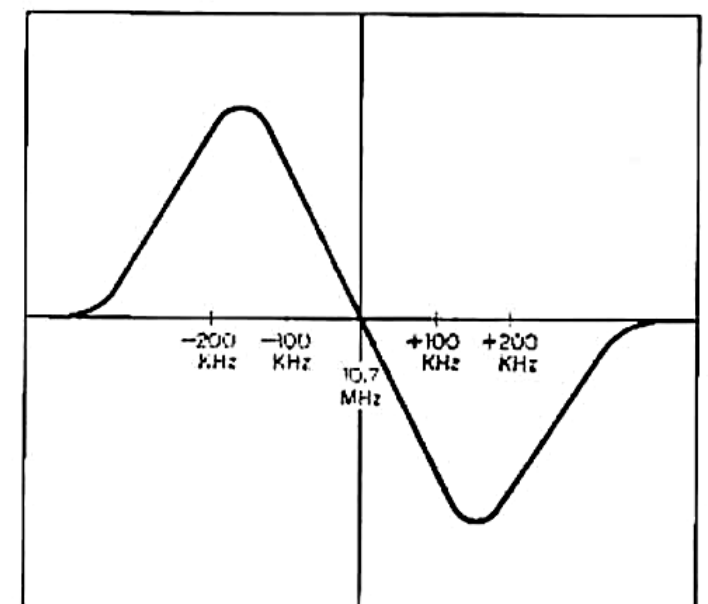

ALIGNMENT

FM MULTIPLEX ALIGNMENT PROCEDURE

1. Do not attempt to align the Multiplex Circuit unless the following equipment is available:

a. Multiplex Stereo Generator b. Oscilloscope c. AC. V.T.V.M. d. Audio Oscillator e. FM Signal Generator

STEP	ALIGN	GENERATOR	FEED SIGNAL	OUTPUT INDICATOR	ADJUST	ADJUST FOR
1.	67 kHz Trap	67 kHz Audio Signal	Connect to TP _{4A}	V.T.V.M. at 4H	L ₄₀₂	Minimum
2.	71 kHz Trap	71 kHz Audio Signal	Connect to TP _{4A}	V.T.V.M. at 4H	L ₄₀₂	Minimum
3.	19 kHz Transformer	FM Signal Gen. Modulated 30% by STEREO Gen. sub-channel	Antenna terminals Tune to signal	V.T.V.M. and Oscilloscope at 4I	T ₄₀₁ , T ₄₀₂	Maximum
4.	38 kHz Transformer	FM Signal Gen. Modulated 30% by STEREO Gen. sub-channel	Antenna terminals Tune to signal	V.T.V.M. and Oscilloscope at 4G	T ₄₀₁	Maximum
5.	Separation VR	FM Signal Gen. Modulated 30% by STEREO Signal Gen. channel-L	Antenna terminals Tune to signal	V.T.V.M. and Oscilloscope at output load channel-R	VR(VR ₆₀₁)	Channel-R Minimum
6.	Repeat 5~6					

AM ALIGNMENT PROCEDURE

NOTE: To align, set the AM Signal Generator level to minimum.

STEP	ALIGN	GENERATOR	FEED SIGNAL	OUTPUT INDICATOR	DIAL SETTING	ADJUST	ADJUST FOR
1.	I.F. Transformer	455 kHz ± 30 kHz Sweep-generator	Antenna terminals	Oscilloscope and V.T.V.M. is connected to 3H		Primary and secondary sides from the 1st I.F.T. (T ₃₀₂ ~ T ₃₀₄)	Best I.F.T. wave form
2.	O.S.C.	AM-generator 600 kHz 400 Hz 30% Modulation	Antenna terminals	Oscilloscope and V.T.V.M. at output load	600 kHz	O.S.C. Coil T ₃₀₁	Maximum
3.	O.S.C.	AM-generator 1400 kHz 400 Hz 30% Modulation	Antenna terminals	Oscilloscope and V.T.V.M. at output load	1400 kHz	O.S.C. Trimmer cap. TC ₃₀₂	Maximum
4.	Repeat 2 and 3						
5.	Antenna circuit	AM-generator 600 kHz 400 Hz 30% Modulation	Antenna terminals	Oscilloscope and V.T.V.M. at output load	600 kHz	Ferrite bar Antenna coil L ₃₀₃	Maximum
6.	Antenna circuit	AM-generator 1400 kHz 400 Hz 30% Modulation	Antenna terminals	Oscilloscope and V.T.V.M. at output load	1400 kHz	Antenna circuit Trimmer TC ₃₀₁	Maximum
7.	Repeat 5 and 6						

AM IF CHARACTERISTIC

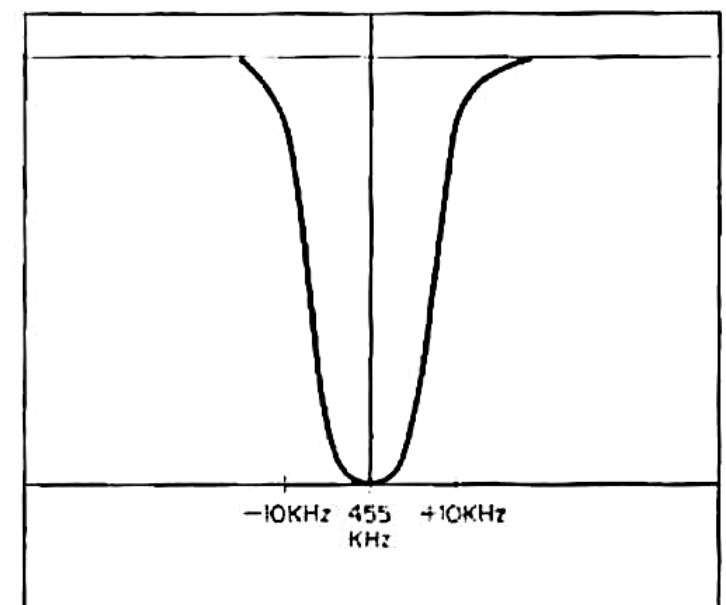

PRINTED CIRCUIT SHEETS AND PARTS LIST

FM IF BLOCK <F-1087B>

X	Y	Z
R201	4.7kΩ ±10% ¼W Carbon Resistor	2 A
R202	180kΩ ±10% ¼W Carbon Resistor	1 A
R203	390Ω ±10% ¼W Carbon Resistor	2 A
R204	560Ω ±10% ¼W Carbon Resistor	1 A
R205	22Ω ±10% ¼W Carbon Resistor	1 B
R206	12kΩ ±10% ¼W Carbon Resistor	2 B
R207	6.8kΩ ±10% ¼W Carbon Resistor	2 B
R208	1kΩ ±10% ¼W Carbon Resistor	2 B
R209	820Ω ±10% ¼W Carbon Resistor	1 B
R210	22Ω ±10% ¼W Carbon Resistor	1 C
R211	6.8kΩ ±10% ¼W Carbon Resistor	2 C
R212	10kΩ ±10% ¼W Carbon Resistor	2 C
R213	1kΩ ±10% ¼W Carbon Resistor	2 C
R214	680Ω ±10% ¼W Carbon Resistor	1 C
R215	22Ω ±10% ¼W Carbon Resistor	1 D
R216	10kΩ ±10% ¼W Carbon Resistor	2 D
R217	6.8kΩ ±10% ¼W Carbon Resistor	2 D
R218	1kΩ ±10% ¼W Carbon Resistor	2 E
R219	1kΩ ±10% ¼W Carbon Resistor	1 D
R220	1.5kΩ ±10% ¼W Carbon Resistor	1 E
R221	1kΩ ±10% ¼W Carbon Resistor	2 E
R222	10kΩ ±10% ¼W Carbon Resistor	1 F
R223	10kΩ ±10% ¼W Carbon Resistor	2 F
R224	68Ω ±10% ¼W Carbon Resistor	1 E
R225	22Ω ±10% ¼W Carbon Resistor	1 E
R226	100kΩ ±10% ¼W Carbon Resistor	3 C
R227	12kΩ ±10% ¼W Carbon Resistor	2 C
R228	1kΩ ±10% ¼W Carbon Resistor	3 A
R229	22kΩ ±10% ¼W Carbon Resistor	2 C
R230	39kΩ ±10% ¼W Carbon Resistor	3 B
R231	22kΩ ±10% ¼W Carbon Resistor	3 D
R232	10kΩ ±10% ¼W Carbon Resistor	3 C
R233	1kΩ ±10% ¼W Carbon Resistor	2 D
R234	22Ω ±10% ¼W Carbon Resistor	3 D
R236	39kΩ ±10% ¼W Carbon Resistor	2 E
R237	12kΩ ±10% ¼W Carbon Resistor	2 F
C201	1000 pF +80% -20% 25 WV Ceramic Capacitor	2 A
C202	0.02 μF +80% -20% 25 WV Ceramic Capacitor	2 A
C203	0.02 μF +80% -20% 25 WV Ceramic Capacitor	1 B
C204	0.02 μF +80% -20% 25 WV Ceramic Capacitor	2 B
C205	0.02 μF +80% -20% 25 WV Ceramic Capacitor	2 B
C206	0.02 μF +80% -20% 25 WV Ceramic Capacitor	1 C
C207	0.02 μF +80% -20% 25 WV Ceramic Capacitor	2 C
C208	0.02 μF +80% -20% 25 WV Ceramic Capacitor	2 C
C209	0.02 μF +80% -20% 25 WV Ceramic Capacitor	2 D
C210	0.02 μF +80% -20% 25 WV Ceramic Capacitor	1 D
C211	0.04 μF +80% -20% 25 WV Ceramic Capacitor	1 F
C212	220 pF ±10% 50 WV Ceramic Capacitor	1 E
C213	220 pF ±10% 50 WV Ceramic Capacitor	2 E
C214	10 μF 10 WV Electrolytic Capacitor	1 F
C215	47 pF ±10% 50 WV Ceramic Capacitor	3 B
C216	100 pF ±10% 50 WV Ceramic Capacitor	3 B

X: Parts No Y: Parts Name Z: Position of Parts
(Co-ordinate number and letter in Printed circuit)

X	Y	Z
C217	3.3 μF 25 WV Electrolytic Capacitor	3 A
C218	0.02 μF +80% -20% 25 WV Ceramic Capacitor	3 A
C219	1000 pF +80% -20% 25 WV Ceramic Capacitor	3 C
C220	1000 pF +80% -20% 25 WV Ceramic Capacitor	3 B
C221	0.47 μF 25 WV Electrolytic Capacitor	3 A
C222	0.04 μF +80% -20% 25 WV Ceramic Capacitor	3 B
C223	2.2 pF ±10% 50 WV Ceramic Capacitor	2 C
C224	0.02 μF +80% -20% 25 WV Ceramic Capacitor	2 D
C225	0.01 μF +80% -20% 25 WV Ceramic Capacitor	2 E
C226	0.02 μF +80% -20% 25 WV Ceramic Capacitor	3 E
C227	0.02 μF +80% -20% 25 WV Ceramic Capacitor	3 E
C228	0.02 μF +80% -20% 25 WV Ceramic Capacitor	3 D
C229	0.02 μF +80% -20% 25 WV Ceramic Capacitor	2 D
C230		
C231	0.02 μF +80% -20% 25 WV Ceramic Capacitor	
C232	0.04 μF +80% -20% 25 WV Ceramic Capacitor	
C234	0.02 μF +80% -20% 25 WV Ceramic Capacitor	
C235	47 pF ±10% 50 WV Ceramic Capacitor	
C236	47 pF ±10% 50 WV Ceramic Capacitor	2 C
VR201	50kΩ (B) Semi-Variable Resistor (103020)	2 F
VR202	200kΩ (B) Semi-Variable Resistor (103035)	3 E
T201	10.7Mc FM IFT (423532)	1 B
T202	10.7Mc FM IFT (423533)	1 C
T203	10.7Mc FM IFT (423533)	1 D
T204	10.7Mc FM Detector Transformer (423534)	4 E
T205	10.7Mc FM Meter Transformer (423529)	3 D
TR201	25C829 (000546-1)	2 A
TR202	25C829 (030546)	2 B
TR203	25C829 (030546)	2 C
TR204	25C829 (030546)	2 D
TR205	25C829 (030546-1)	3 D
TR206	25C828 (030527)	3 F
D201	IN60 Diode (031033)	3 B
D202	IN60 Diode (031033)	3 C
D203	IN60 Diode (031033)	3 E
D204	IN60 Diode (031033)	2 C
VD201	DS410 Varistor (031046)	3 B
VD202	DS410 Varistor (031046)	3 E

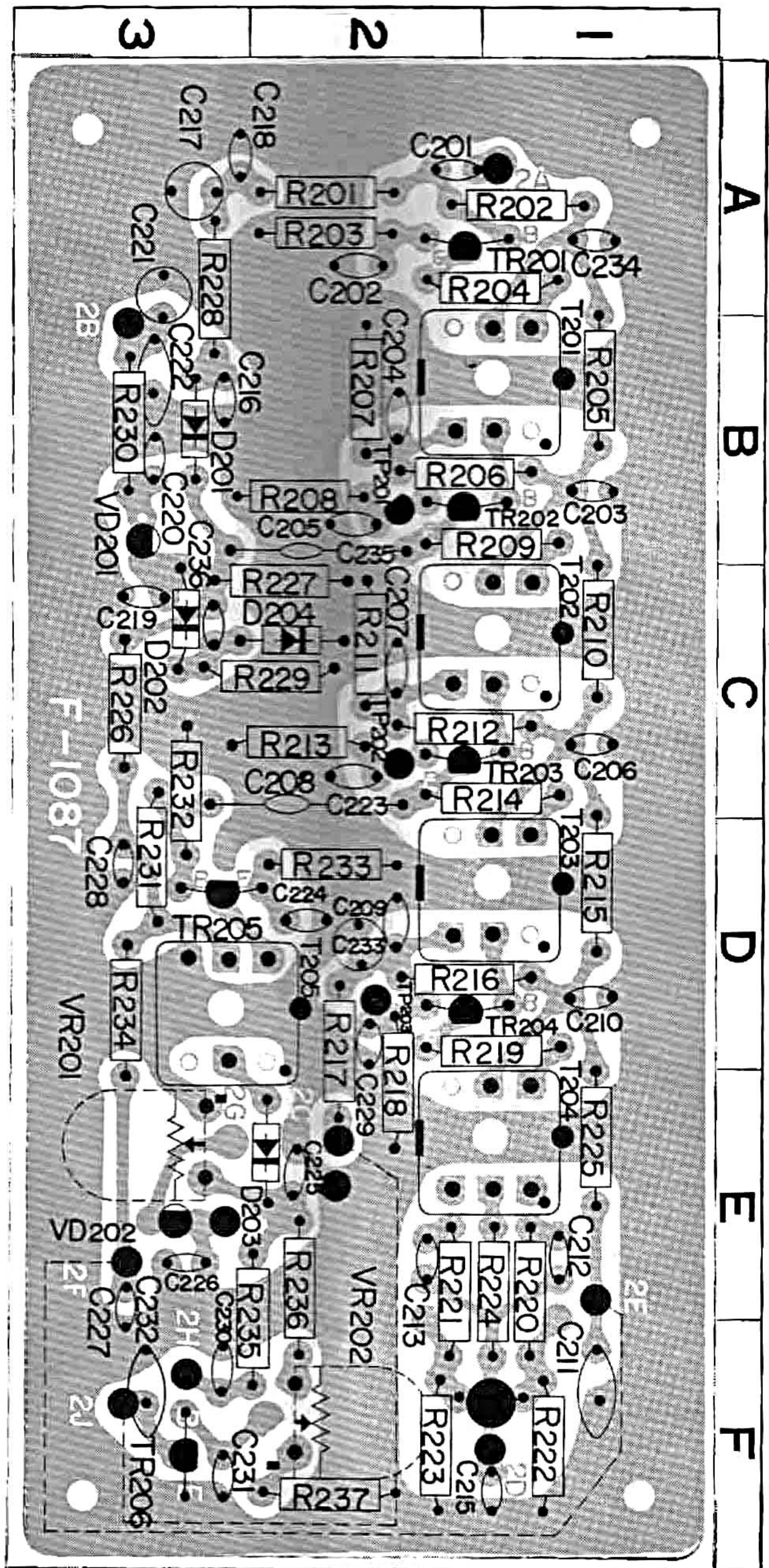

PRINTED CIRCUIT SHEETS AND PARTS LIST

FM MULTIPLEX <F-1072-2A>

X	Y	Z
R401	1k Ω \pm 10% 1/4W Carbon Resistor	1 E
R402	100k Ω \pm 10% 1/4W Carbon Resistor	1 E
R403	100k Ω \pm 10% 1/4W Carbon Resistor	1 E
R404	22k Ω \pm 10% 1/4W Carbon Resistor	1 E
R405	680 Ω \pm 10% 1/4W Carbon Resistor	1 E
R406	100 Ω \pm 10% 1/4W Carbon Resistor	2 D
R407	22k Ω \pm 10% 1/4W Carbon Resistor	2 D
R408	47k Ω \pm 10% 1/4W Carbon Resistor	2 D
R409	2.2k Ω \pm 10% 1/4W Carbon Resistor	2 D
R410	470 Ω \pm 10% 1/4W Carbon Resistor	1 C
R411	2.2k Ω \pm 10% 1/4W Carbon Resistor	3 C
R412	10k Ω \pm 10% 1/4W Carbon Resistor	2 C
R413	10k Ω \pm 10% 1/4W Carbon Resistor	2 C
R414	3.3k Ω \pm 10% 1/4W Carbon Resistor	2 D
R415	3.3k Ω \pm 10% 1/4W Carbon Resistor	3 C
R416	1k Ω \pm 10% 1/4W Carbon Resistor	3 C
R417	100k Ω \pm 10% 1/4W Carbon Resistor	2 C
R418	18k Ω \pm 10% 1/4W Carbon Resistor	1 B
R419	5.6k Ω \pm 10% 1/4W Carbon Resistor	2 C
R420	470 Ω \pm 10% 1/4W Carbon Resistor	2 C
R421	47 Ω \pm 10% 1/4W Carbon Resistor	2 C
R422	22k Ω \pm 10% 1/4W Carbon Resistor	1 A
R423	22k Ω \pm 10% 1/4W Carbon Resistor	1 A
R424	22k Ω \pm 10% 1/4W Carbon Resistor	3 A
R425	22k Ω \pm 10% 1/4W Carbon Resistor	2 A
R426	100k Ω \pm 10% 1/4W Carbon Resistor	1 A
R427	100k Ω \pm 10% 1/4W Carbon Resistor	3 B
R428	220k Ω \pm 10% 1/4W Carbon Resistor	1 A
R429	220k Ω \pm 10% 1/4W Carbon Resistor	3 A
R430	10k Ω \pm 10% 1/4W Carbon Resistor	3 E
C401	100 pF \pm 20% 50 WV Ceramic Capacitor	1 E
C402	1 μ F 50 WV Electrolytic Capacitor	1 E
C403	33 μ F 6.3 WV Electrolytic Capacitor	1 E
C404	5000 pF \pm 5% 50 WV Mica Capacitor	1 D
C405	10 μ F 25 WV Electrolytic Capacitor	2 E
C406	220 pF \pm 5% 50 WV Mica Capacitor	3 E
C407	0.02 μ F \pm 100% 50 WV Ceramic Capacitor	1 D
C408	1500 pF \pm 5% 50 WV Mica Capacitor	3 E
C409	6800 pF \pm 5% 50 WV Mica Capacitor	1 C
C410	47 μ F 25 WV Electrolytic Capacitor	3 D
C411	10 μ F 25 WV Electrolytic Capacitor	3 B
C412	0.02 μ F \pm 100% 50 WV Ceramic Capacitor	3 C
C413	0.02 μ F \pm 100% 50 WV Ceramic Capacitor	2 B
C414	1700 pF \pm 5% 50 WV Mica Capacitor	2 B
C415	1 μ F 50 WV Electrolytic Capacitor	3 C
C416	10 μ F 10 WV Electrolytic Capacitor	3 B
C417	220 pF \pm 20% 50 WV Ceramic Capacitor	1 A
C418	220 pF \pm 20% 50 WV Ceramic Capacitor	3 A
C419	560 pF \pm 5% 50 WV Mica Capacitor	1 B
C420	560 pF \pm 5% 50 WV Mica Capacitor	3 B
C421	1000 pF \pm 5% 50 WV Mica Capacitor	1 B
C422	1000 pF \pm 5% 50 WV Mica Capacitor	3 B
C423	0.047 μ F \pm 10% 50 WV Mylar Capacitor	1 A
C424	0.047 μ F \pm 10% 50 WV Mylar Capacitor	3 A

X: Parts No Y: Parts Name Z: Position of Parts
(Co-ordinate number and letter in Printed circuit)

X	Y	Z
T401	19kHz Coil (424028)	1 D
T402	19kHz Coil (424029)	1 C
T403	38kHz Coil (424029)	2 B
L401	3.8mH Inductor (424026)	2 E
L402	23mH Inductor (424027)	3 E
TR401	25C536E (030515-4)	1 E
TR402	25C536E (030515-4)	2 C
TR403	25C536E (030515-4)	2 C
TR404	25A564i (Par Q) (030008-1)	2 C
TR405	25C536E (030515-4)	3 C
TR406	25C458L(D) (030531-2)	3 B
D401	1N34A Diode (031040)	1 B
D402	1N34A Diode (031040)	1 B
D403	1N34A Diode (031040-1)	2 A
D404	1N34A Diode (031040-1)	2 A
D405	1N34A Diode (031040-1)	2 A
D406	1N34A Diode (031040-1)	2 A
CR401	FP-38A CR (080008)	1 A
CR402	FP-38A CR (080008)	3 A

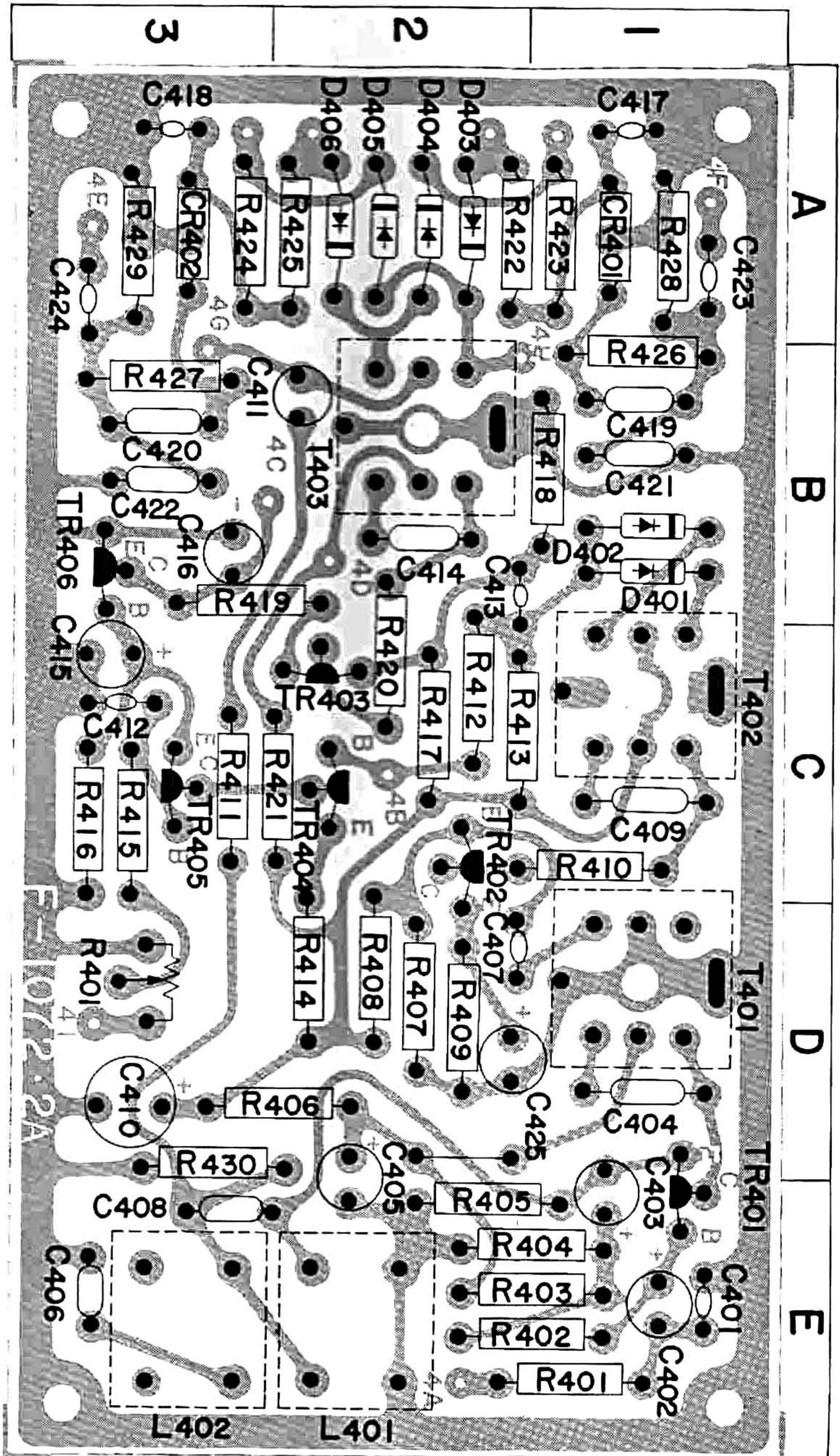

PRINTED CIRCUIT SHEETS AND PARTS LIST

AM BLOCK (F-1054A)

X	Y	Z
R301	3.3kΩ ±10% ¼W Carbon Resistor	2A
R302	100kΩ ±10% ¼W Carbon Resistor	2A
R303	3.9kΩ ±10% ¼W Carbon Resistor	2A
R304	27kΩ ±10% ¼W Carbon Resistor	2A
R305	1kΩ ±10% ¼W Carbon Resistor	1A
R306	220Ω ±10% ¼W Carbon Resistor	2A
R307	150kΩ ±10% ¼W Carbon Resistor	2B
R308	12kΩ ±10% ¼W Carbon Resistor	1B
R309	220Ω ±10% ¼W Carbon Resistor	2B
R310	220Ω ±10% ¼W Carbon Resistor	2C
R311	220Ω ±10% ¼W Carbon Resistor	1B
R312	1kΩ ±10% ¼W Carbon Resistor	2B
R313	27kΩ ±10% ¼W Carbon Resistor	2C
R314	6.8kΩ ±10% ¼W Carbon Resistor	1C
R315	220Ω ±10% ¼W Carbon Resistor	1C
R316	100Ω ±10% ¼W Carbon Resistor	2B
R317	1kΩ ±10% ¼W Carbon Resistor	2C
R318	150kΩ ±10% ¼W Carbon Resistor	1C
R319	10kΩ ±10% ¼W Carbon Resistor	1C
R320	1kΩ ±10% ¼W Carbon Resistor	1D
R321	10kΩ ±10% ¼W Carbon Resistor	1D
R322	1kΩ ±10% ¼W Carbon Resistor	1D
R323	1kΩ ±10% ¼W Carbon Resistor	2D
C302	0.04μF ±100% 50 WV Ceramic Capacitor	2A
C303	0.04μF ±100% 50 WV Ceramic Capacitor	2A
C304	0.04μF ±100% 50 WV Ceramic Capacitor	2A
C305	0.01μF ±10% 50 WV Mylar Capacitor	1A
C306	430pF ±10% 50 WV Mica Capacitor	1B
C307	10pF ±10% 50 WV Ceramic Capacitor	1B
C308	0.04μF ±100% 50 WV Ceramic Capacitor	2B

X: Parts No Y: Parts Name Z: Position of Parts
(Co-ordinate number and letter in Printed circuit)

X	Y	Z
C309	0.04μF ±100% 50 WV Ceramic Capacitor	1B
C310	0.04μF ±100% 50 WV Ceramic Capacitor	1B
C311	0.04μF ±100% 50 WV Ceramic Capacitor	2B
C312	1μF 50 WV Electrolytic Capacitor	1A
C313	0.04μF ±100% 50 WV Ceramic Capacitor	1C
C314	0.04μF ±100% 50 WV Ceramic Capacitor	2C
C315	0.04μF ±100% 50 WV Ceramic Capacitor	1C
C316	0.04μF ±100% 50 WV Ceramic Capacitor	2C
C317	0.04μF ±100% 50 WV Ceramic Capacitor	2C
C318	0.01μF ±10% 50 WV Mylar Capacitor	2D
C319	0.04μF ±100% 50 WV Ceramic Capacitor	1C
C320	0.02μF ±10% 50 WV Mylar Capacitor	1D
C321	0.02μF ±100% 50 WV Ceramic Capacitor	2D
C322	0.01μF ±10% 50 WV Mylar Capacitor	1D
C323	0.04μF ±100% 50 WV Ceramic Capacitor	2D
VR301	20kΩ(B) Semi-Variable Resistor (103046)	2D
T301	AM OSC Coil (423017)	1A
T302	455kHz IFT (423016)	2A
T303	455kHz IFT (423015)	2B
T304	455kHz IFT (423014)	2C
TR301	25C829 (030546-1)	1A
TR302	25C829 (030546-1)	2B
TR303	25C829 (030546)	2C
D301	IN34A Diode (031040)	2B
D302	IN34A Diode (031040)	1D
D303	IN34A Diode (031040)	2D

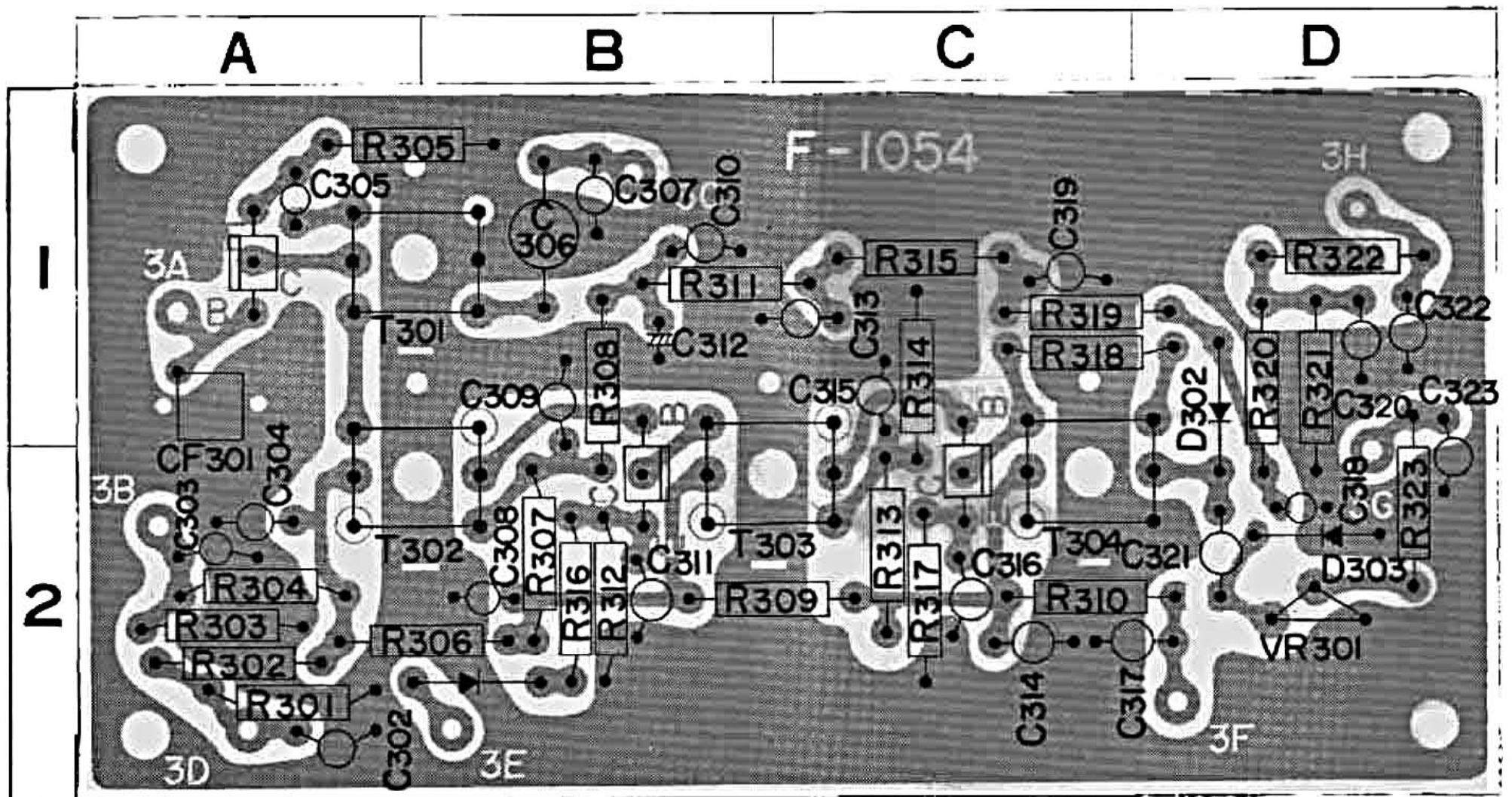

EQUALIZER AMP <F-1037A>

X	Y	Z
R601	1 kΩ ±10% ¼W Carbon Resistor	1 A
R602	680 kΩ ±10% ¼W Carbon Resistor	1 A
R603	4.7 kΩ ±10% ¼W Carbon Resistor	1 A
R604	100 kΩ ±10% ¼W Carbon Resistor	1 A
R605	1.8 kΩ ±10% ¼W Carbon Resistor	1 A
R606	390 Ω ±10% ¼W Carbon Resistor	1 B
R607	270 kΩ ±10% ¼W Carbon Resistor	1 B
R608	6.8 kΩ ±10% ¼W Carbon Resistor	1 C
R609	220 Ω ±10% ¼W Carbon Resistor	1 B
R610	820 Ω ±10% ¼W Carbon Resistor	1 B
R611	100 Ω ±10% ¼W Carbon Resistor	1 D
R612	82 kΩ ±10% ¼W Carbon Resistor	1 D
R615	22 kΩ ±10% ¼W Carbon Resistor	1 D
R616	330 kΩ ±10% ¼W Carbon Resistor	1 C
R617	8.2 kΩ ±10% ¼W Carbon Resistor	1 C
R618	1 kΩ ±10% ¼W Carbon Resistor	2 A
R619	680 kΩ ±10% ¼W Carbon Resistor	2 A
R620	47 kΩ ±10% ¼W Carbon Resistor	2 C
R621	100 kΩ ±10% ¼W Carbon Resistor	2 A
R622	1.8 kΩ ±10% ¼W Carbon Resistor	2 A
R623	390 Ω ±10% ¼W Carbon Resistor	2 B
R624	270 kΩ ±10% ¼W Carbon Resistor	2 B
R625	6.8 kΩ ±10% ¼W Carbon Resistor	2 C
R626	220 Ω ±10% ¼W Carbon Resistor	2 B
R627	820 Ω ±10% ¼W Carbon Resistor	2 B
R628	100 Ω ±10% ¼W Carbon Resistor	2 D
R629	82 kΩ ±10% ¼W Carbon Resistor	2 D

X	Y	Z
R632	22 kΩ ±10% ¼W Carbon Resistor	2 D
R633	330 kΩ ±10% ¼W Carbon Resistor	2 C
R634	8.2 kΩ ±10% ¼W Carbon Resistor	2 C
C601	1.5 μF 15 WV Tantalum Capacitor	1 A
C602	150 pF ±10% 50 WV Ceramic Capacitor	1 A
C603	33 μF 6.3 WV Electrolytic Capacitor	1 B
C604	33 μF 6.3 WV Electrolytic Capacitor	1 B
C605	150 pF ±10% 50 WV Ceramic Capacitor	1 B
C606	47 μF 6.3 WV Electrolytic Capacitor	1 B
C607	10 μF 50 WV Electrolytic Capacitor	1 B
C609	0.01 μF ±10% 50 WV Mylar Capacitor	1 C
C610	0.0033 μF ±10% 50 WV Mylar Capacitor	1 C
C611	1.5 μF 15 WV Tantalum Capacitor	2 A
C612	150 pF ±10% 50 WV Ceramic Capacitor	2 A
C613	33 μF 6.3 WV Electrolytic Capacitor	2 B
C614	33 μF 6.3 WV Electrolytic Capacitor	2 B
C615	150 pF ±10% 50 WV Ceramic Capacitor	2 B
C616	47 μF 6.3 WV Electrolytic Capacitor	2 B
C617	10 μF 50 WV Electrolytic Capacitor	2 B
C619	0.01 μF ±10% 50 WV Mylar Capacitor	2 C
C620	0.0033 μF ±10% 50 WV Mylar Capacitor	2 C
TR601	2SC458LG (030531-1)	1 B
TR602	2SC281 (030512-2)	1 B
TR603	2SC458LG (030531-1)	2 B
TR604	2SC281 (030512-2)	2 B

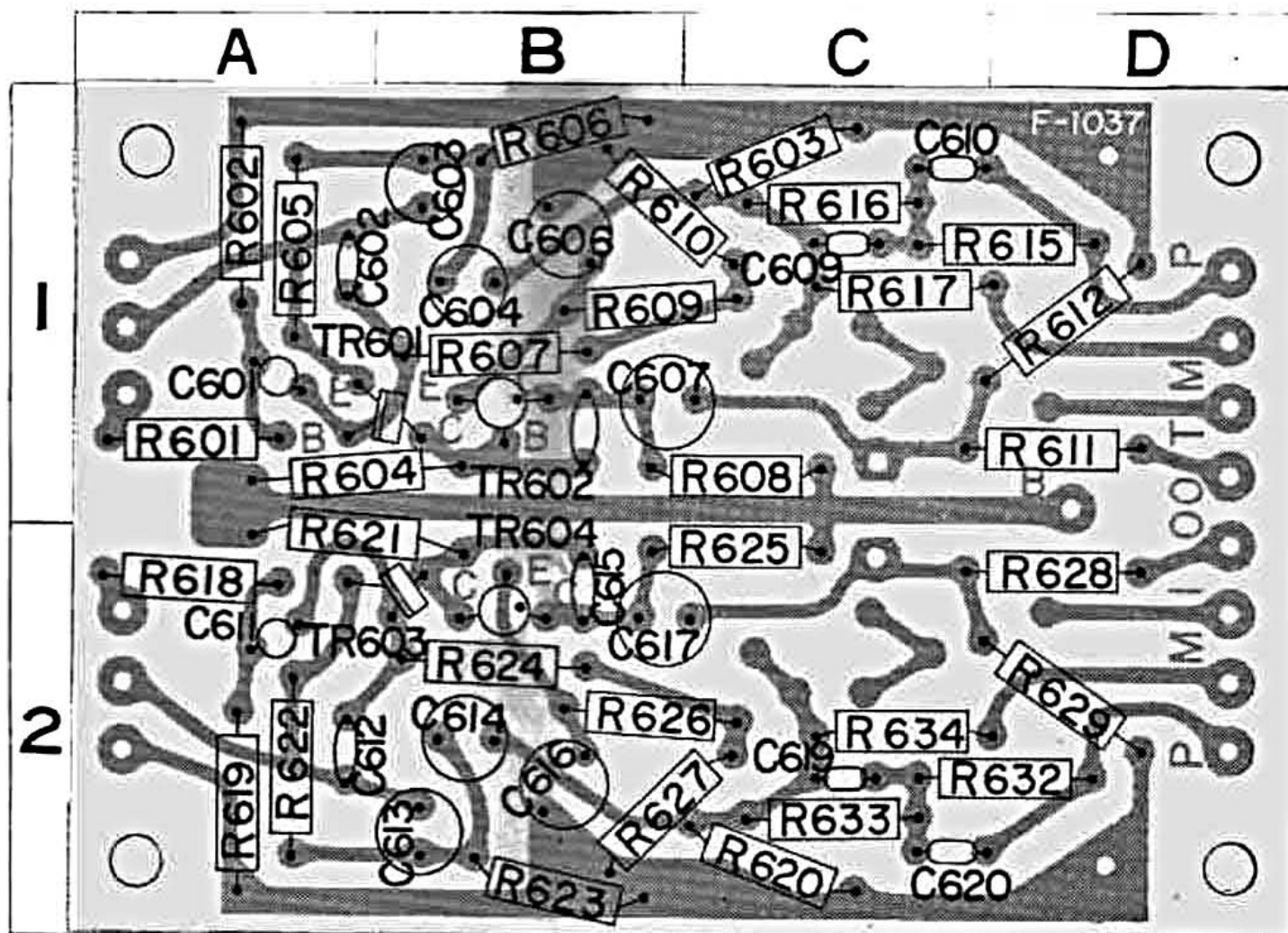

PRINTED CIRCUIT SHEETS AND PARTS LIST

MAIN AMP <F-1100>

X	Y	Z
R801	2.2k Ω \pm 10% $\frac{1}{4}$ W Carbon Resistor	2A
R802	2.2k Ω \pm 10% $\frac{1}{4}$ W Carbon Resistor	2A
R803	680k Ω \pm 10% $\frac{1}{4}$ W Carbon Resistor	1A
R804	680k Ω \pm 10% $\frac{1}{4}$ W Carbon Resistor	1A
R805	150k Ω \pm 10% $\frac{1}{4}$ W Carbon Resistor	1A
R806	150k Ω \pm 10% $\frac{1}{4}$ W Carbon Resistor	1A
R807	4.7k Ω \pm 10% $\frac{1}{4}$ W Carbon Resistor	1A
R808	4.7k Ω \pm 10% $\frac{1}{4}$ W Carbon Resistor	1A
R809	3.3k Ω \pm 10% $\frac{1}{4}$ W Carbon Resistor	3A
R810	3.3k Ω \pm 10% $\frac{1}{4}$ W Carbon Resistor	3A
R811	100 Ω \pm 10% $\frac{1}{4}$ W Carbon Resistor	3B
R812	100 Ω \pm 10% $\frac{1}{4}$ W Carbon Resistor	3B
R815	22k Ω \pm 10% $\frac{1}{2}$ W Solid Resistor	1C
R816	22k Ω \pm 10% $\frac{1}{2}$ W Solid Resistor	1C
R817	8.2k Ω \pm 10% $\frac{1}{4}$ W Carbon Resistor	2C
R818	8.2k Ω \pm 10% $\frac{1}{4}$ W Carbon Resistor	2C
R819	1k Ω \pm 10% $\frac{1}{4}$ W Carbon Resistor	1C
R820	1k Ω \pm 10% $\frac{1}{4}$ W Carbon Resistor	1C
R821	6.8k Ω \pm 10% $\frac{1}{4}$ W Carbon Resistor	3B
R822	6.8k Ω \pm 10% $\frac{1}{4}$ W Carbon Resistor	3B
R823	4.7k Ω \pm 10% $\frac{1}{4}$ W Solid Resistor	1C
R824	4.7k Ω \pm 10% $\frac{1}{2}$ W Solid Resistor	1C
R825	120 Ω \pm 10% $\frac{1}{4}$ W Carbon Resistor	3B
R826	120 Ω \pm 10% $\frac{1}{4}$ W Carbon Resistor	3B
R827	10 Ω \pm 10% $\frac{1}{4}$ W Carbon Resistor	1D
R828	10 Ω \pm 10% $\frac{1}{4}$ W Carbon Resistor	1D
R829	220 Ω \pm 10% $\frac{1}{4}$ W Carbon Resistor	2C
R830	220 Ω \pm 10% $\frac{1}{4}$ W Carbon Resistor	2C
R831	33 Ω \pm 10% $\frac{1}{4}$ W Carbon Resistor	2C
R832	33 Ω \pm 10% $\frac{1}{4}$ W Carbon Resistor	2C
R833	220 Ω \pm 10% $\frac{1}{4}$ W Carbon Resistor	3C
R834	220 Ω \pm 10% $\frac{1}{4}$ W Carbon Resistor	3C
R835	10 Ω \pm 10% $\frac{1}{4}$ W Carbon Resistor	1D
R836	10 Ω \pm 10% $\frac{1}{4}$ W Carbon Resistor	1D
R837	10 Ω \pm 10% $\frac{1}{4}$ W Carbon Resistor	3D
R838	10 Ω \pm 10% $\frac{1}{4}$ W Carbon Resistor	3D
R839	0.7 Ω \pm 10% 1W Wire-Wound Resistor	1D
R840	0.7 Ω \pm 10% 1W Wire-Wound Resistor	1D
R841	10 Ω \pm 10% $\frac{1}{2}$ W Solid Resistor	3C
R842	10 Ω \pm 10% $\frac{1}{2}$ W Solid Resistor	3C
R843	0.7 Ω \pm 10% 1W Wire-Wound Resistor	3D
R844	0.7 Ω \pm 10% 1W Wire-Wound Resistor	3D
C801	1 μ F 50 WV Electrolytic Capacitor	1A
C802	1 μ F 50 WV Electrolytic Capacitor	1A
C803	100 pF 50 WV Electrolytic Capacitor	3A
C804	100 μ F 50 WV Electrolytic Capacitor	3A
C805	100 μ F 6.3 WV Electrolytic Capacitor	3A
C806	100 μ F 6.3 WV Electrolytic Capacitor	3A
C807	1 μ F 50 WV Electrolytic Capacitor	1A
C808	1 μ F 50 WV Electrolytic Capacitor	1A
C809	10 μ F 50 WV Electrolytic Capacitor	2B
C810	10 μ F 50 WV Electrolytic Capacitor	2B
C811	47 μ F 50 WV Electrolytic Capacitor	1B
C812	47 μ F 50 WV Electrolytic Capacitor	1B
C813	100 μ F 6.3 WV Electrolytic Capacitor	3B
C814	100 μ F 6.3 WV Electrolytic Capacitor	3B

X: Parts No Y: Parts Name Z: Position of Parts
(Co-ordinate number and letter in Printed circuit)

X	Y	Z
C815	47 pF \pm 10% 50 WV Ceramic Capacitor	1A
C816	47 pF \pm 10% 50 WV Ceramic Capacitor	1A
C817	0.04 μ F \pm 10% 50 WV Mylar Capacitor	2C
C818	0.04 μ F \pm 10% 50 WV Mylar Capacitor	2C
C819	300 pF \pm 10% 50 WV Ceramic Capacitor	3C
C820	300 pF \pm 10% 50 WV Ceramic Capacitor	3C
VR801	200k Ω (B) Semi-Variable Resistor (103015)	
VR802	200k Ω (B) Semi-Variable Resistor (103015)	
VR803	200 Ω (B) Semi-Variable Resistor (103012)	
VR804	200 Ω (B) Semi-Variable Resistor (103012)	
TR801	25C281 (030512-1)	2A
TR802	25C281 (030512-1)	2A
TR803	25C734 (030536-1)	2B
TR804	25C734 (030536-1)	2B
TR805	25C734 (030536-1)	1C
TR806	25C734 (030536-1)	1C
TR807	25A561 (030010-1)	2B
TR808	25A561 (030010-1)	2B
D801	D5410 Varistor (031046)	2B
D802	D5410 Varistor (031046)	2B
D803	D5410 Varistor (031046)	1B
D804	D5410 Varistor (031046)	1B

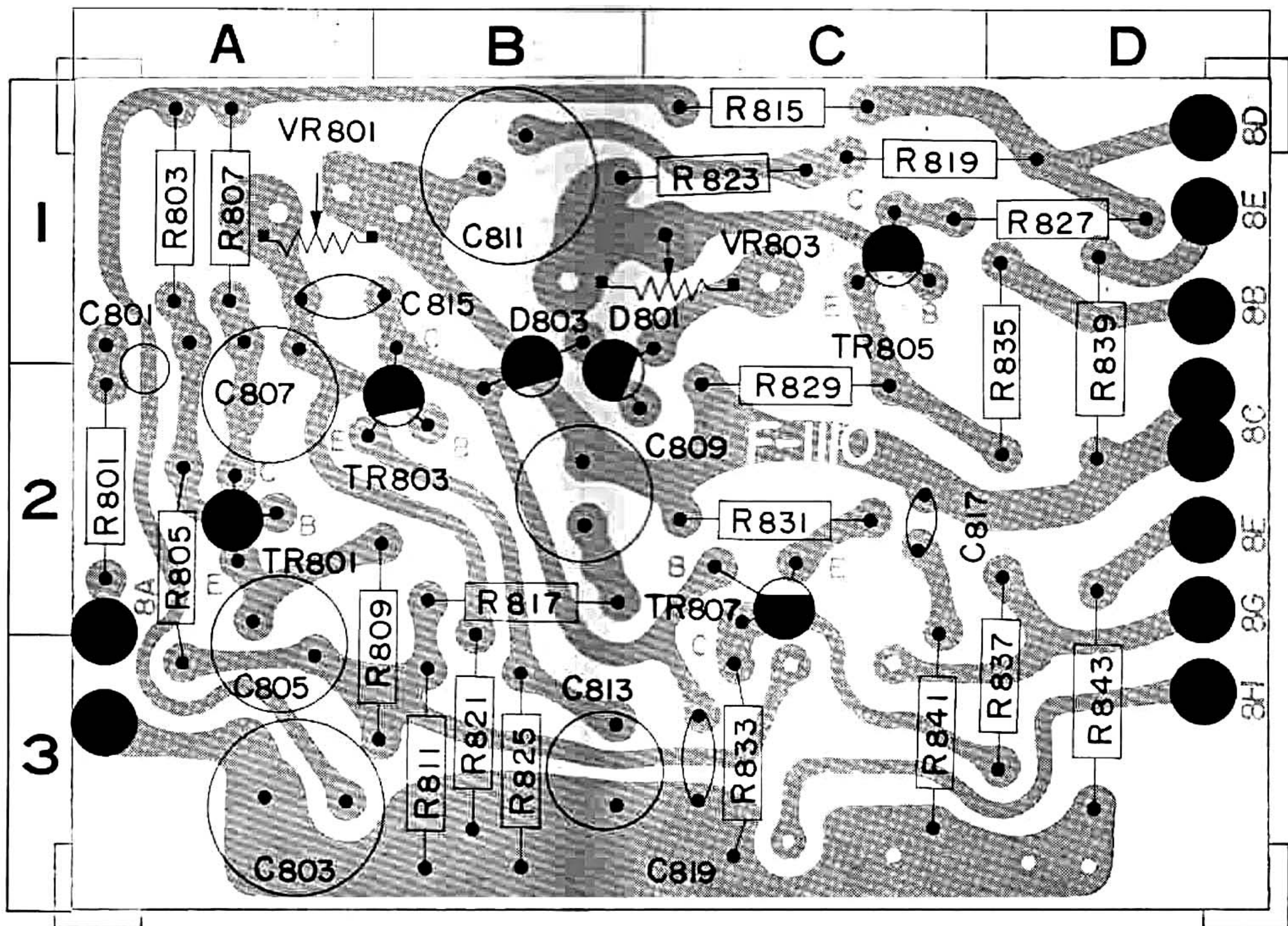

PRINTED CIRCUIT SHEETS AND PARTS LIST

TONE CONTROL AMP <F-1094>

X	Y	Z
R705	1kΩ ±10% ¼W Carbon Resistor	2B
R706	1kΩ ±10% ¼W Carbon Resistor	2C
R707	1MΩ ±10% ¼W Carbon Resistor	2B
R708	1MΩ ±10% ¼W Carbon Resistor	2C
R709	15kΩ ±10% ¼W Carbon Resistor	1B
R710	15kΩ ±10% ¼W Carbon Resistor	1C
R711	560Ω ±10% ¼W Carbon Resistor	2A
R712	560Ω ±10% ¼W Carbon Resistor	2D
R713	18kΩ ±10% ¼W Carbon Resistor	1B
R714	18kΩ ±10% ¼W Carbon Resistor	1C

X: Parts No Y: Parts Name Z: Position of Parts
(Co-ordinate number and letter in Printed circuit)

X	Y	Z
C705	1μF 50 WV Electrolytic Capacitor	2B
C706	1μF 50 WV Electrolytic Capacitor	2C
C707	3.3μF 25 WV Electrolytic Capacitor	1A
C708	3.3μF 25 WV Electrolytic Capacitor	1D
C709	0.001μF ±10% 50 WV Mylar Capacitor	1B
C710	0.001μF ±10% 50 WV Mylar Capacitor	1C
TR601	2SC458 LG (C) (030531-1)	1B
TR602	2SC458 LG (C) (030531-1)	1C

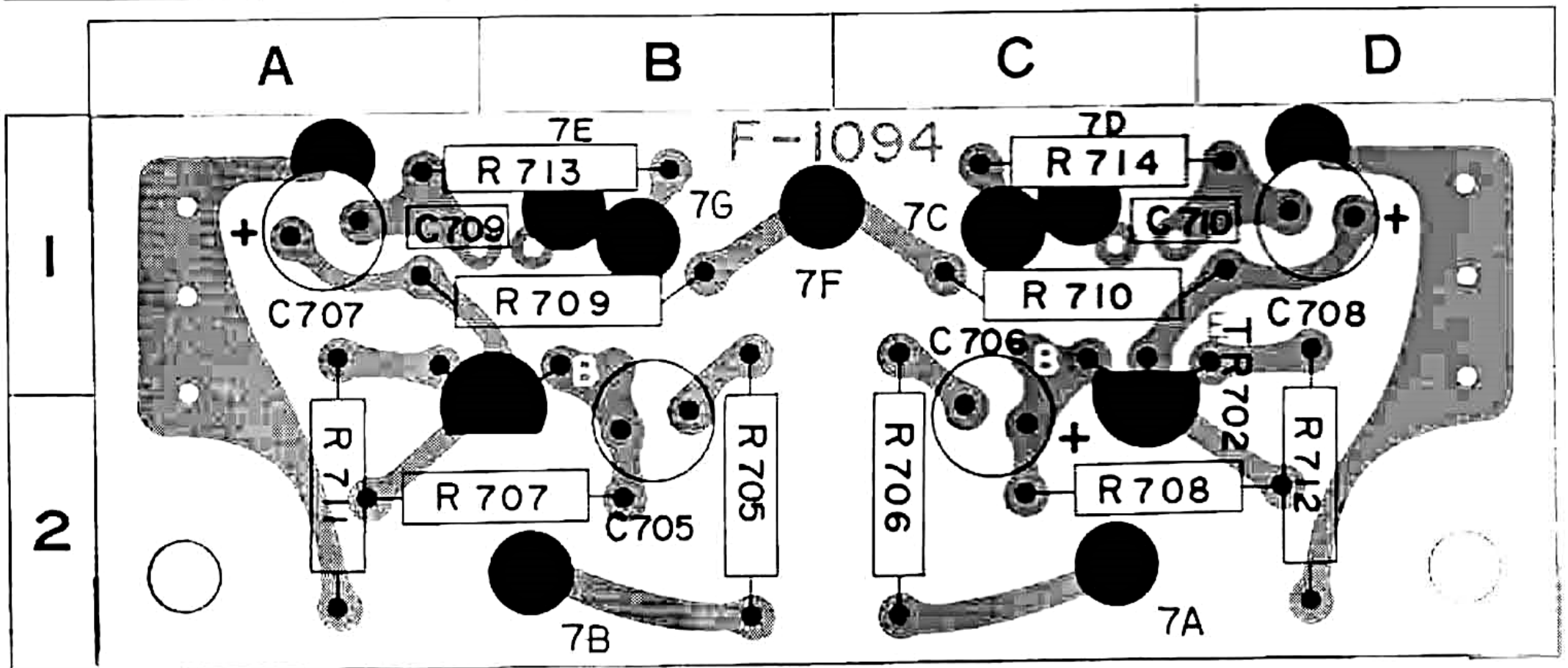

POWER <F-1114>

X	Y	Z
D001	SW-1-02 Diode (031055)	1C
D002	SW-05-02 Diode (035017)	1D
D003	SW-05-02 Diode (031017)	1B
C002	220μF 10 WV Electrolytic Capacitor	1A
C010	0.01μF 400 WV Oil Capacitor	1C
C011	0.01μF 400 WV Oil Capacitor	1C

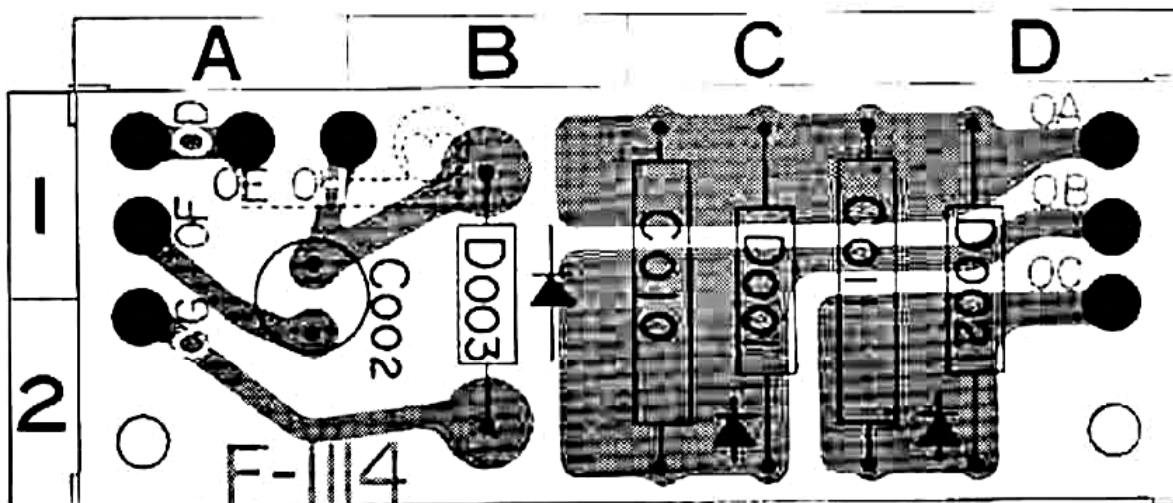

OTHER PARTS AND THEIR POSITION ON CHASSIS

OTHER PARTS LIST

X	Y
R120	680Ω ±10% ¼W Carbon Resistor
R121	68Ω ±10% ¼W Carbon Resistor
C120	0.02μF ±100% 50 WV Ceramic Capacitor
T101	300:75Ω (F-1010)
S8	SL 13-8-10H Slide Switch (111004)
R334	10kΩ ±10% ¼W Carbon Resistor
R335	6.8kΩ ±10% ¼W Carbon Resistor
C301	0.04μF ±100% 50WV Ceramic Capacitor
C324	0.01μF ±10% 50WV Mylar Capacitor
VC301 TC301	F-1010 AM Variable Capacitor (081015)
L302	1μH Coil (429003)
L303	ARS-48A Antenna Coil (420010)
R431	3.3MΩ ±10% ½W Solid Resistor
C428	470pF ±10% 50 WV HIQ Capacitor
PL401	6V 30mA Pilot Lamp (040011)
R635	100kΩ ±10% ½W Solid Resistor
R636	4.7kΩ ±10% ¼W Carbon Resistor
R637	100Ω ±10% ¼W Carbon Resistor
R638	100kΩ ±10% ¼W Carbon Resistor
R639	220kΩ ±10% ¼W Carbon Resistor
R640	220kΩ ±10% ¼W Carbon Resistor
R641	100kΩ ±10% ¼W Carbon Resistor
R642	100kΩ ±10% ½W Solid Resistor
R643	4.7kΩ ±10% ¼W Carbon Resistor
R644	68kΩ ±10% ¼W Carbon Resistor
R645	68kΩ ±10% ¼W Carbon Resistor
VR601	10kΩ(B) Variable Resistor (100502)
C621	0.002μF ±10% 50WV Mylar Capacitor
R701	12kΩ ±10% ¼W Carbon Resistor
R702	12kΩ ±10% ¼W Carbon Resistor
R703	15kΩ ±10% ½W Solid Resistor
R704	15kΩ ±10% ½W Solid Resistor
R705	22kΩ ±10% ¼W Carbon Resistor
R706	22kΩ ±10% ¼W Carbon Resistor
R717	12kΩ ±10% ¼W Carbon Resistor
R718	12kΩ ±10% ¼W Carbon Resistor
R719	3.9kΩ ±10% ½W Solid Resistor
R720	3.9kΩ ±10% ½W Solid Resistor
R721	1.2kΩ ±10% ½W Solid Resistor
R722	1.2kΩ ±10% ½W Solid Resistor
R723	1MΩ ±10% ¼W Carbon Resistor
R724	1MΩ ±10% ¼W Carbon Resistor

X: Parts No Y: Parts Name

X	Y
C701	180pF ±10% 50 WV HIQ Capacitor
C702	180pF ±10% 50 WV HIQ Capacitor
C703	0.022μF ±10% 50 WV Mylar Capacitor
C704	0.022μF ±10% 50 WV Mylar Capacitor
C711	0.01μF ±10% 50 WV Mylar Capacitor
C712	0.01μF ±10% 50 WV Mylar Capacitor
C713	0.1μF ±10% 50 WV Mylar Capacitor
C714	0.1μF ±10% 50 WV Mylar Capacitor
C715	0.01μF ±10% 50 WV Mylar Capacitor
C716	0.01μF ±10% 50 WV Mylar Capacitor
C717	0.007μF ±15% 50 WV Mylar Capacitor
C718	0.007μF ±10% 50 WV Mylar Capacitor
R845	390Ω ±10% ½W Solid Resistor
R846	390Ω ±10% ½W Solid Resistor
R847	180Ω ±10% 3 W
R848	180Ω ±10% 3 W
C821	2000μF 35 WV Electrolytic Capacitor (020527)
C822	2000μF 35 WV Electrolytic Capacitor (020527)
VR701	125kΩ(M) } Balance, Variable Resistor (103034)
VR702	125kΩ(N) }
VR703	250kΩ(B) } Volume, Variable Resistor (101035)
VR704	250kΩ(B) }
VR705	100kΩ(A) } Treble, Variable Resistor (102005)
VR706	100kΩ(A) }
VR707	100kΩ(A) } Bass, Variable Resistor (102005)
VR708	100kΩ(A) }
TR809	25D180 (030806-1~3)
TR810	25D180 (030806-1~3)
TR811	25D180 (030806-1~3)
TR812	25D180 (030806-1~3)
F801	2.5A Quick Acting Fuse (043011)
F802	2.5A Quick Acting Fuse (043011)
PL801	25V 90mA Pilot Lamp (040007)
PL802	25V 90mA Pilot Lamp (040007)
R001	120Ω ±10% ½W Carbon Resistor
R002	47Ω ±10% ½W Solid Resistor
R003	270Ω ±10% ½W Solid Resistor
R004	560Ω ±10% ½W Solid Resistor
R005	560Ω ±10% ½W Solid Resistor
R006	2.2kΩ ±10% ½W Solid Resistor
R007	1kΩ ±10% ½W Solid Resistor
R008	1.8kΩ ±10% ½W Solid Resistor
R009	1kΩ ±10% ½W Solid Resistor
C001	2000μF 60 WV Electrolytic Capacitor (020519-1)
C003	2000μF 35 WV Electrolytic Capacitor (020527)
C004	330μF 35 WV Electrolytic Capacitor
C005	470μF 25 WV Electrolytic Capacitor
C006	470μF 25 WV Electrolytic Capacitor
C007	1000μF 16 WV Electrolytic Capacitor
M001	100μA Tuning Meter (090015-1)

OTHER PARTS AND THEIR POSITION ON CHASSIS

OTHER PARTS LIST

X	Y
C008	1000 μ F 16 WV Electrolytic Capacitor
C009	330 μ F 25 WV Electrolytic Capacitor
C012	0.0047 μ F 600WV Oil Capacitor
C013	0.033 μ F 600WV Oil Capacitor
S1(a~i)	Selector Switch (110317)
S2(a~d)	Speaker Switch (110111)
S3(a, b)	SJ-1855 Lever Switch (117006)
S4(a, b)	SJ-1855 Lever Switch (117006)
S5(a, b)	SJ-1855 Lever Switch (117006)
S6(a, b)	SJ-1855 Lever Switch (117006)
S7(a, b)	SJ-1855 Lever Switch (117006)
S001	EUQA8E R11 Power Switch (113009)
D004	SW-05-02 Diode (031017)
T001	400-5312 Power Transformer (400040)

X: Parts No Y: Parts Name

X	Y
F001	2.5A GTD Power Fuse (043025)
PL001	6.3V 250mA Pilot Lamp (040008)
PL002	6.3V 250mA Pilot Lamp (040008)
PL003	6.3V 250mA Pilot Lamp (040008)
PL004	6.3V 250mA Pilot Lamp (040008)
PL005	6.3V 250mA Pilot Lamp (040008)
PL006	8V 150mA Pilot Lamp (040008)
PL007	5V 60mA Pilot Lamp (040010)
CO001	AC Consent 2P (245001)
PU001	Voltage Selector X-B0001 (241006); X-10001 (241009)
J001	Headphone Jack 3P 64M (243007)
J002	DIN Jack 5-1 8113 (243004)

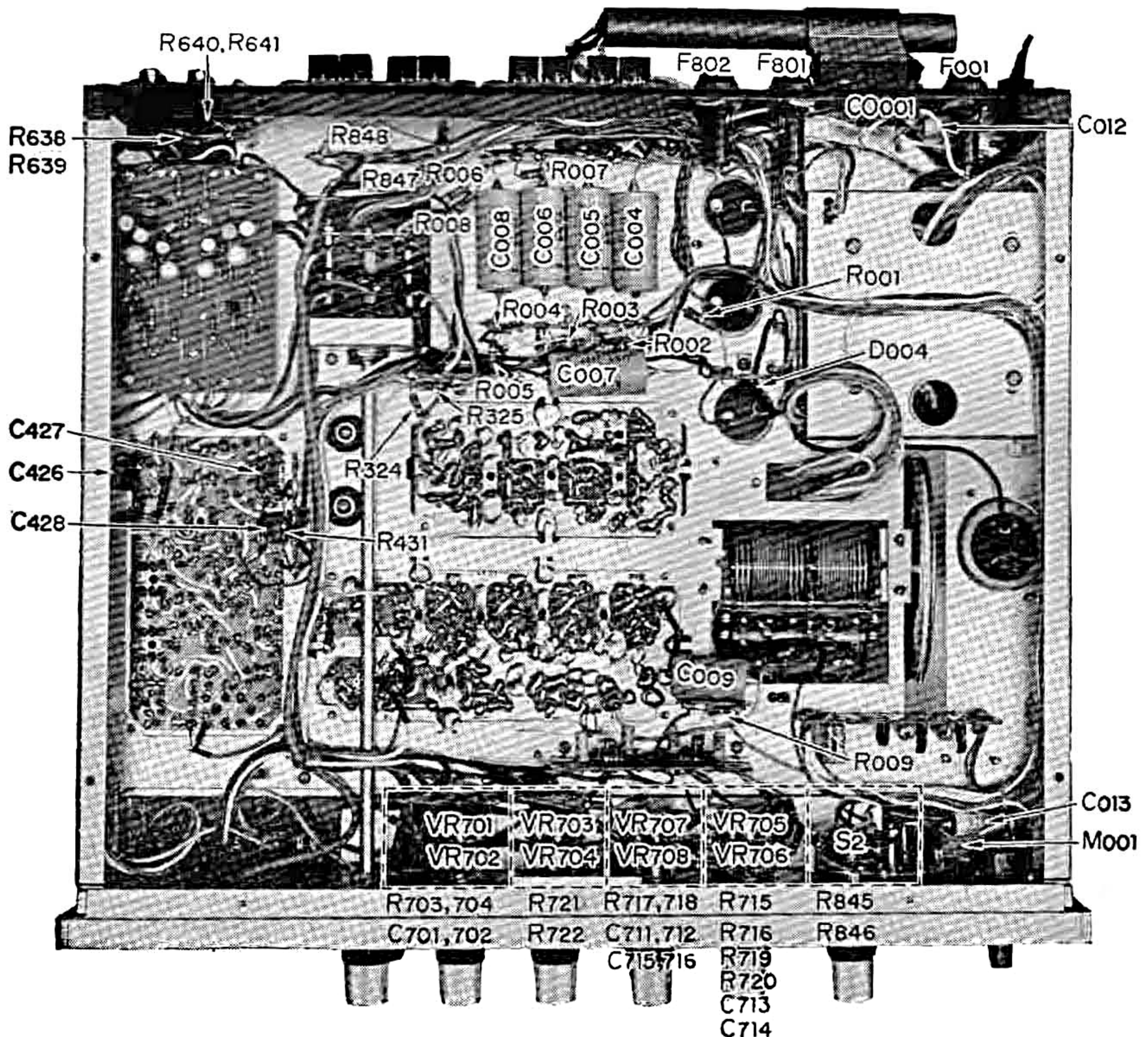

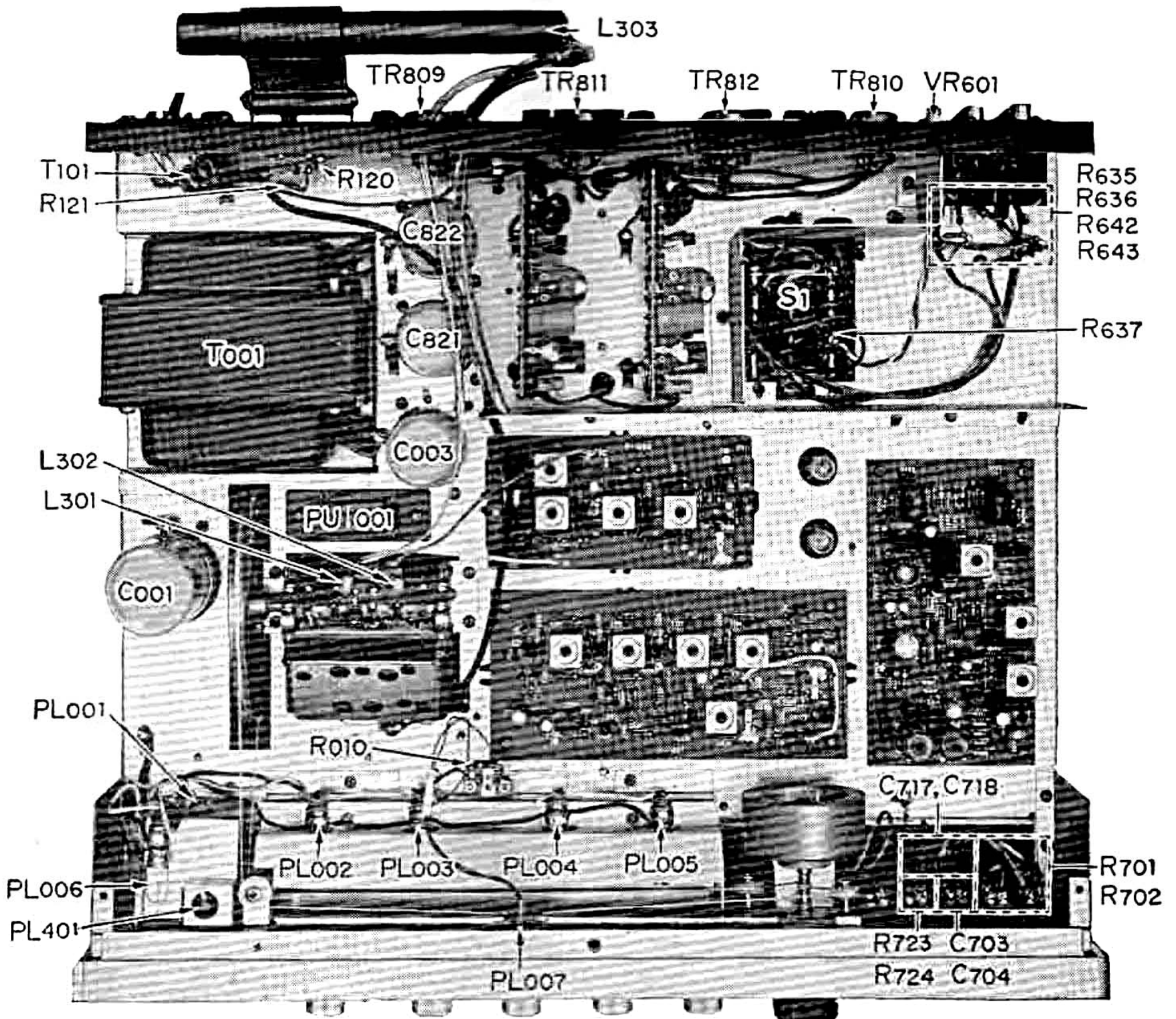

SANSUI 800 SCHEMATIC DIAGRAM

